

1 | Overview

This module is an SDI2 compatible, POPIT expansion module that communicates to the control panel over the SDI2 bus.

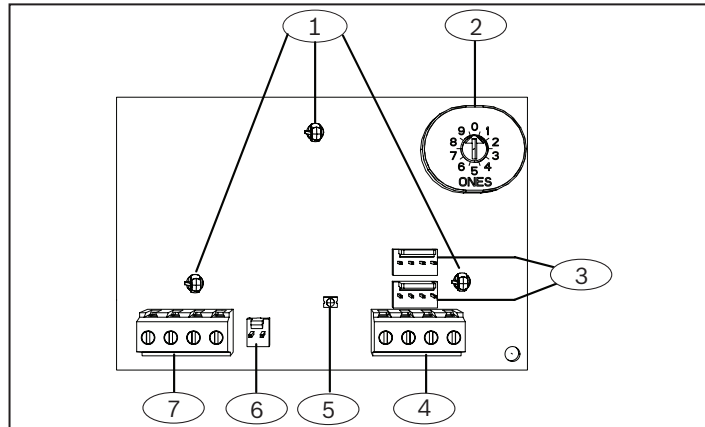

Callout – Description

| |
|--|
| 1 – 3-hole mounting pattern |
| 2 – Address switch |
| 3 – SDI2 interconnect wiring connectors (to control panel or additional modules) |
| 4 – SDI2 terminal strip (to control panel or additional modules) |
| 5 – Heartbeat LED (blue) |
| 6 – Tamper switch (optional) connector |
| 7 – POPEX terminal strip (POPIT Bus) |

2 | SDI2 address settings

The switch sets the address for the module. The control panel uses the address for communications. The address also sets the output numbers. Set the address switch per the control panel configuration.



NOTICE!

The module reads the address switch setting during power up. If you change the switches after you apply power to the module, cycle the power to the module in order for the new setting to be enabled.

If multiple B299 modules are on the same system, each B299 module must have a unique address. The figure below shows the address switch settings for address 0.

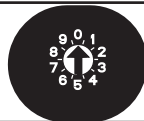

2.1 | Address and point numbers per control panel

Valid B299 addresses are dependant on the number of points allowed by a particular control panel.

| Control panel | Valid B299 addresses | Corresponding point numbers |
|--------------------|----------------------|---|
| B9512G B9512G-E | 0 - 5 | 9 - 99, 100 - 199, 200 - 299, 300 - 399, 400 - 499, 500 - 599 |
| B8512G B8512G-E | 0 | 9 - 99 |

3 | Installation

Set the address switch for the proper address and then install the module into the enclosure. Wire the module to the control panel.



CAUTION!

Remove all power (AC and battery) before making any connections. Failure to do so might result in personal injury and/or equipment damage.

3.1 | Mount the module in the enclosure

Mount the module into the enclosure's 3-hole mounting pattern using the mounting screws and mounting bracket. Refer to Figure 3.1.

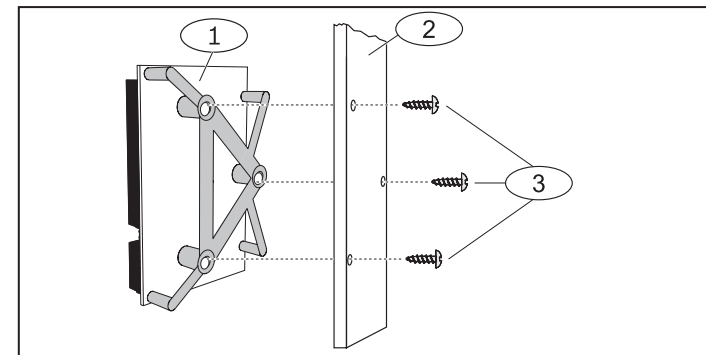

Figure 3.1: Mounting the module in the enclosure

Callout – Description

| |
|--|
| 1 – Module with mounting bracket installed |
| 2 – Enclosure |
| 3 – Mounting screws (3) |

3.2 | Mount and wire the tamper switch

You can connect an optional tamper switch for one module in an enclosure.

Installing the optional tamper switch:

- Mount the ICP-EZTS Tamper Switch (P/N: F01U009269) into the enclosure's tamper switch mounting location. For complete instructions, refer to *EZTS Cover and Wall Tamper Switch Installation Guide* (P/N: F01U003734).
- Plug the tamper switch wire onto the module's tamper switch connector. Refer to Figure 1.1.

3.3 | Wire to the control panel

Use the control panel terminals labeled R, Y, G, B (PWR, A, B, COM) when wiring to the module. Connect them to the module terminals labeled R, Y, G, B (PWR, A, B, COM). You can also use the SDI2 innerconnect cable. Refer to Figures 3.2 and 3.3.

You can connect modules to the SDI2 data bus by parallel wire run from the control panel to each module, wire from module to module, or a combination of the two techniques. Refer to Figure 3.4.



NOTICE!

Use either the terminal strip wiring **or** interconnect wiring connector to the control panel. Do not use both. When connecting multiple modules, you can combine terminal strip and interconnect wiring connectors in series.

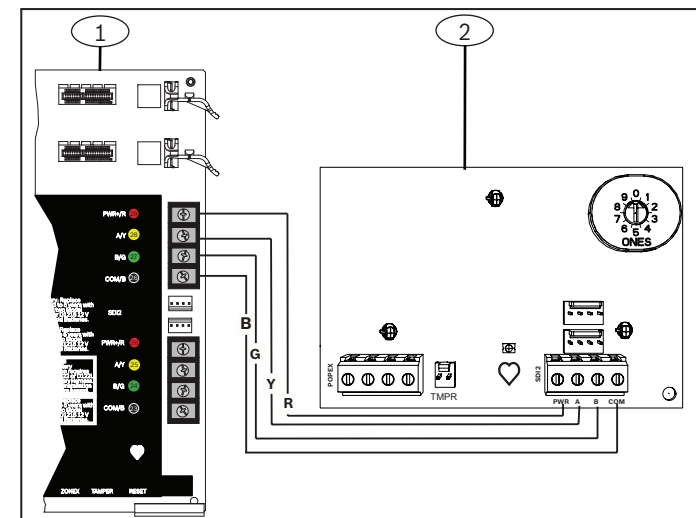

Figure 3.2: SDI2 terminal wiring from control panel to B299

Callout – Description

| |
|-------------------------|
| 1 – Bosch control panel |
| 2 – B299 POPEX module |

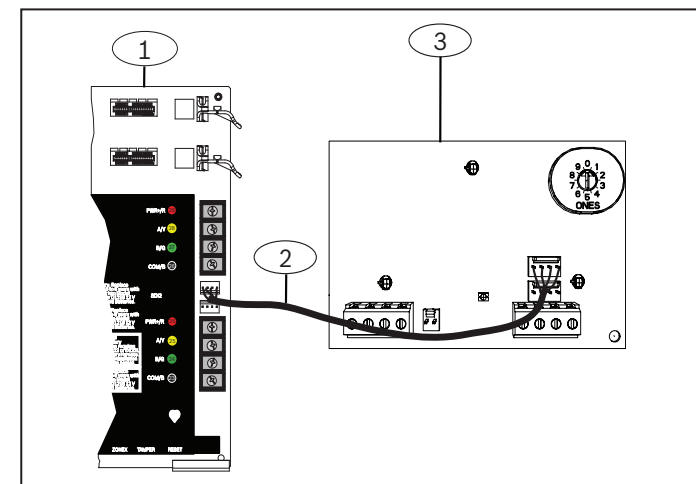

Figure 3.3: SDI2 innerconnect cable wiring from control panel to B299

Callout – Description

| |
|---|
| 1 – Bosch control panel |
| 2 – Innerconnect cable (P/N: F01U79745, included) |
| 3 – B299 POPEX module |

3.4 | Wire to the POPIT devices

Refer to Figure 3.4 to wire a zone expansion loop. Wire resistance on each sensor loop must be less than 100 Ω with the detection devices connected. The terminal strip supports 12 to 22 AWG (2.0 to 0.65 mm) wires.

| Maximum length of all data expansion loops combined | |
|---|---------------|
| AWG | Length ft (m) |
| 22 (0.8) | 1800 (549) |
| 20 (1.0) | 2890 (881) |
| 18 (1.2) | 4600 (1402) |
| 16 (1.5) | 7320 (2231) |
| 14 (1.8) | 11650 (3551) |

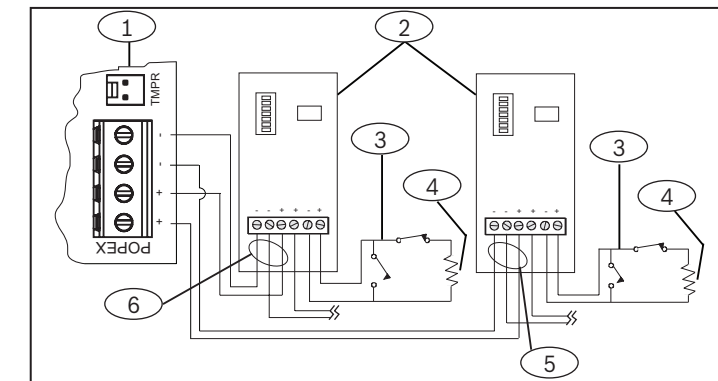

Figure 3.4: Wiring a zone expansion loop

Callout – Description

| |
|---|
| 1 – B299 |
| 2 – POPIT module (D9127U/T shown) |
| 3 – D9127 sensor loop |
| 4 – 33 kΩ EOL resistor (P/N: 15-03130-022) |
| 5 – POPEX loop 2 (electrically identical to loop 1) |
| 6 – POPEX loop 1 (electrically identical to loop 2) |

4 | LED descriptions

The module includes one blue heartbeat LED to indicate that the module has power and to indicate the module's current state. Refer to Table 4.1.

| Flash Pattern | Function |
|-----------------------------------|--|
| Flashes once every 1 sec | Normal state. Indicates normal operation state. |
| 3 quick flashes every 1 sec x3 | Communication error state. Indicates (the module is in a “no communication state”) resulting in an SDI2 communication error. |
| ON Steady | LED trouble state. Module is not powered (for OFF Steady only), or some other trouble condition prohibits the module from controlling the heartbeat LED. |
| OFF Steady | |

Table 4.1: LED descriptions

5 | Show the firmware version

To show the firmware version using an LED flash pattern:

- If the optional tamper switch is installed: With the enclosure door open, activate the tamper switch (push and release the switch).
- If the optional tamper switch is NOT installed: Momentarily short the tamper pins.

Refer to Figure 5.1 for an example of flash patterns.

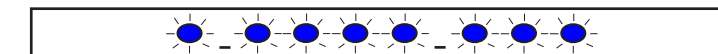

Figure 5.1: Firmware LED flash patterns

When the tamper switch is activated (closed to open), the heartbeat LED stays OFF for 3 sec before indicating the firmware version. The LED pulses the major, minor, and micro digits of the firmware version, with a 1 sec pause after each digit.

Flashing patterns do not start until the tamper is open (short is removed). In the following example, the version 1.4.3 shows as LED flashes:

[3 sec pause] * _ * * * _ * * * [3 sec pause, then normal operation].

6 Configuration

Use the following POPIT programming table to configure the POPIT switch block. Switches are designated as being “ON” or “OFF.” These are depicted in the table below by the following; ON = o, OFF = blank.

For example the switch settings for x09 looks like this: **o,o,o,blank,o,o,blank** (On,On,On,Off,On,On,Off).

| Point number | Switch | | | | | | |
|--------------|--------|---|---|---|---|---|---|
| | 0 | 1 | 2 | 3 | 4 | 5 | 6 |
| B299 | | | | | | | |
| x00* | o | o | o | o | o | o | o |
| x01* | o | o | o | o | o | o | o |
| x02* | o | o | o | o | o | o | o |
| x03* | o | o | o | o | o | o | o |
| x04* | o | o | o | o | o | o | o |
| x05* | o | o | o | o | o | o | o |
| x06* | o | o | o | o | o | o | o |
| x07* | o | o | o | o | o | o | o |
| x08* | o | o | o | o | o | o | o |
| x09 | o | o | o | o | o | o | o |
| x10 | o | o | o | o | o | o | o |
| x11 | o | o | o | o | o | o | o |
| x12 | o | o | o | o | o | o | o |
| x13 | o | o | o | o | o | o | o |
| x14 | o | o | o | o | o | o | o |
| x15 | o | o | o | o | o | o | o |
| x16 | o | o | o | o | o | o | o |
| x17 | o | o | o | o | o | o | o |
| x18 | o | o | o | o | o | o | o |
| x19 | o | o | o | o | o | o | o |
| x20 | o | o | o | o | o | o | o |
| x21 | o | o | o | o | o | o | o |
| x22 | o | o | o | o | o | o | o |
| x23 | o | o | o | o | o | o | o |
| x24 | o | o | o | o | o | o | o |
| x25 | o | o | o | o | o | o | o |
| x26 | o | o | o | o | o | o | o |
| x27 | o | o | o | o | o | o | o |
| x28 | o | o | o | o | o | o | o |
| x29 | o | o | o | o | o | o | o |
| x30 | o | o | o | o | o | o | o |
| x31 | o | o | o | o | o | o | o |
| x32 | o | o | o | o | o | o | o |
| x33 | o | o | o | o | o | o | o |
| x34 | o | o | o | o | o | o | o |
| x35 | o | o | o | o | o | o | o |
| x36 | o | o | o | o | o | o | o |
| x37 | o | o | o | o | o | o | o |
| x38 | o | o | o | o | o | o | o |
| x39 | o | o | o | o | o | o | o |
| x40 | o | o | o | o | o | o | o |
| x41 | o | o | o | o | o | o | o |
| x42 | o | o | o | o | o | o | o |
| x43 | o | o | o | o | o | o | o |
| x44 | o | o | o | o | o | o | o |
| x45 | o | o | o | o | o | o | o |
| x46 | o | o | o | o | o | o | o |
| x47 | o | o | o | o | o | o | o |
| x48 | o | o | o | o | o | o | o |
| x49 | o | o | o | o | o | o | o |

* Not available for use on B299 at address 0.

| Point number | Switch | | | | | | |
|--------------|--------|---|---|---|---|---|---|
| | 0 | 1 | 2 | 3 | 4 | 5 | 6 |
| B299 | | | | | | | |
| x50 | o | o | o | o | o | o | o |
| x51 | o | o | o | o | o | o | o |
| x52 | o | o | o | o | o | o | o |
| x53 | o | o | o | o | o | o | o |
| x54 | o | o | o | o | o | o | o |
| x55 | o | o | o | o | o | o | o |
| x56 | o | o | o | o | o | o | o |
| x57 | o | o | o | o | o | o | o |
| x58 | o | o | o | o | o | o | o |
| x59 | o | o | o | o | o | o | o |
| x60 | o | o | o | o | o | o | o |
| x61 | o | o | o | o | o | o | o |
| x62 | o | o | o | o | o | o | o |
| x63 | o | o | o | o | o | o | o |
| x64 | o | o | o | o | o | o | o |
| x65 | o | o | o | o | o | o | o |
| x66 | o | o | o | o | o | o | o |
| x67 | o | o | o | o | o | o | o |
| x68 | o | o | o | o | o | o | o |
| x69 | o | o | o | o | o | o | o |
| x70 | o | o | o | o | o | o | o |
| x71 | o | o | o | o | o | o | o |
| x72 | o | o | o | o | o | o | o |
| x73 | o | o | o | o | o | o | o |
| x74 | o | o | o | o | o | o | o |
| x75 | o | o | o | o | o | o | o |
| x76 | o | o | o | o | o | o | o |
| x77 | o | o | o | o | o | o | o |
| x78 | o | o | o | o | o | o | o |
| x79 | o | o | o | o | o | o | o |
| x80 | o | o | o | o | o | o | o |
| x81 | o | o | o | o | o | o | o |
| x82 | o | o | o | o | o | o | o |
| x83 | o | o | o | o | o | o | o |
| x84 | o | o | o | o | o | o | o |
| x85 | o | o | o | o | o | o | o |
| x86 | o | o | o | o | o | o | o |
| x87 | o | o | o | o | o | o | o |
| x88 | o | o | o | o | o | o | o |
| x89 | o | o | o | o | o | o | o |
| x90 | o | o | o | o | o | o | o |
| x91 | o | o | o | o | o | o | o |
| x92 | o | o | o | o | o | o | o |
| x93 | o | o | o | o | o | o | o |
| x94 | o | o | o | o | o | o | o |
| x95 | o | o | o | o | o | o | o |
| x96 | o | o | o | o | o | o | o |
| x97 | o | o | o | o | o | o | o |
| x98 | o | o | o | o | o | o | o |
| x99 | o | o | o | o | o | o | o |

* Not available for use on B299 at address 0.

7 | Certifications



NOTICE!

To meet UL/ULC, all D9127U/T modules are to be mounted inside a metal enclosure.

| Region | Certification |
|--------|--|
| US | UL 365 - Police Station Connected Burglar Alarm Units and Systems |
| | UL 609 - Local Burglar Alarm Units and Systems |
| | UL 636 - Holdup Alarm Units and Systems |
| | UL 864 - Control Units and Accessories for Fire Alarm Systems |
| | UL 985 - Household Fire Warning System Units |
| | UL 1023 - Household Burglar-Alarm System Units |
| | UL 1076 - Proprietary Burglar Alarm Units and Systems |
| | UL 1610 - Central Station Burglar Alarm Units |
| | ANSI/SIA CP-01:2010 |
| | CSFM - California Office of The State Fire Marshal |
| | FCC Part 15 Class B |
| CA | Canada CAN/ULC S303 - Local Burglar Alarm Units and Systems |
| | CAN/ULC S304 - Signal Receiving Centre and Premise Alarm Control Units |
| | ULC-S545 - Residential Fire Warning Alarm Systems Control units |
| | ULC-ORD C1023 - Household Burglar Alarm System Units |
| | ULC-ORD C1076 - Proprietary Burglar Alarm Units and Systems |
| | ICES-003 - Digital Apparatus |

8 | Specifications

| | |
|-----------------------|--|
| Dimensions | 2.9 in x 5.0 in x 0.6 in (73.5 mm x 127 mm x 15.25 mm) |
| Voltage (input) | 12 VDC |
| Current | Standby: 35 mA + total device current Alarm: 35 mA + total device current |
| Operating temperature | 0°C to +50°C (+32°F to +122°F) |
| Relative humidity | 5% to 93% at +32°C (+90°F) non-condensing |
| Terminal wire size | 12 AWG to 22 AWG (2.0 mm to 0.65 mm) |
| SDI2 wiring | Maximum distance - wire size (unshielded wire only): 200 ft (60 m) - 22 AWG (0.65 mm), 500 ft (152 m) - 18 AWG (1.02 mm) |
| POPIT loop wiring | See Section 3.4 <i>Wire to the POPIT devices</i> for POPIT loop wiring lengths. |
| Compatibility | Control panel: B9512G/B9512G-E (6 modules), B8512G/B8512G-E (1 module). (Refer to the control panel installation document for the number of supported devices.) POPIT devices: D9127U/T, ZX776Z/ZX794Z PIR, ZX835 TriTech, ZX935Z/ZX938Z PIR, ZX970 TriTech, D278S 12V smoke base, D298S 24V smoke base, F220-B6PM popit smoke (master), F220-B6PS popit smoke base |

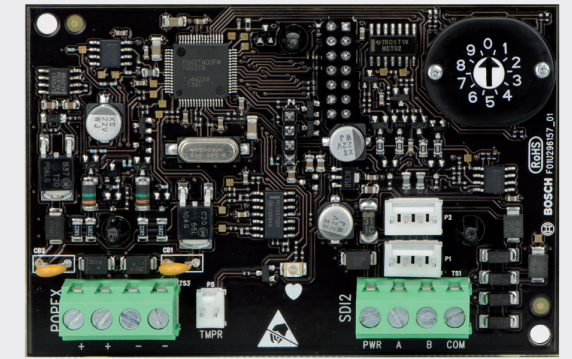

POPEX module
B299



en Quick installation guide

Bosch Security Systems B.V.
Torenallee 49
5617 BA Eindhoven
Netherlands
www.boschsecurity.com

Copyright

This document is the intellectual property of Bosch Security Systems B.V. and is protected by copyright. All rights reserved.

Trademarks

All hardware and software product names used in this document are likely to be registered trademarks and must be treated accordingly.

Bosch Security Systems B.V. product manufacturing dates

Use the serial number located on the product label and refer to the Bosch Security Systems B.V. website at <http://www.boschsecurity.com/datecodes/>.

