

## 1 | Overview

This keypad is SDI2 compatible with four inputs and one output.

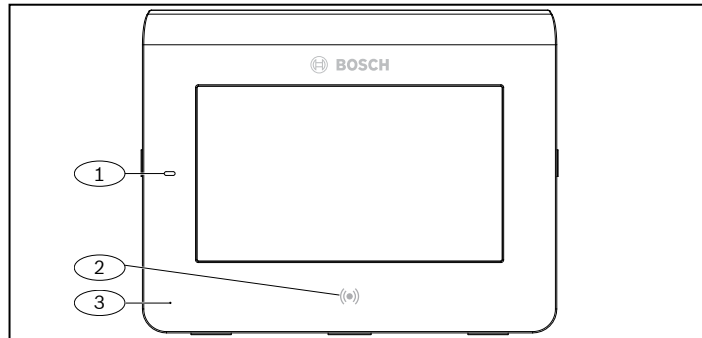

### Callout – Description

- |  |
|--|
| 1 – Power indicator LED  |
| 2 – Integrated proximity reader (for use with RF ID tokens and access cards) |
| 3 – Presence sensor  |

## 2 | Installation

### 2.1 | Remove the mounting plate

1. Insert a slotted screwdriver under the retention clip to release the clip. Do not twist upwards.
2. Move the plate towards the bottom of the keypad. Refer to the following illustration.

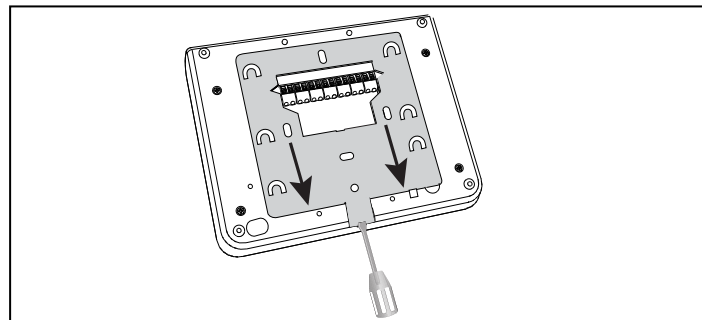

### 2.2 | Install the mounting plate

1. Use the flush mounting plate (Left side in the following illustration) or the surface mounting plate (Right side in the following illustration).
2. Use the plate as a template to mark the wall for installation.
3. Make sure it is level.
4. Pull the wiring through the wiring opening.

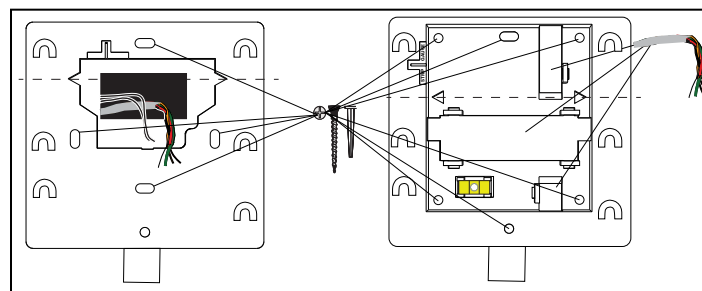

## 3 | Connecting the wires to the keypad

Attach the wires to the keypad and to any inputs or outputs before you install the keypad.

**CAUTION!**  
Remove all power (AC and battery) before making any connections. Failure to do so might result in personal injury and/or equipment damage.

**NOTICE!**  
To prevent damage to the terminals, use a ballpoint pen. Do not use a screwdriver.

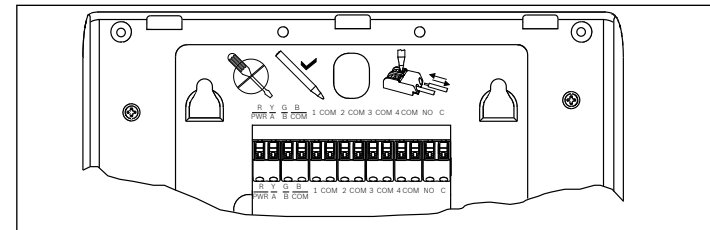

**NOTICE!**  
Use the strip gauge on the plate to reduce wires to 7 mm. Attach one wire per terminal.

1. Put the keypad on a smooth surface.
2. Use a ballpoint pen to press the button on the terminal release.
3. Put the wire into the terminal. When you remove the pen, the terminal release locks the wire.
4. To remove wires, press the terminal release.
5. Gently pull the wire out.

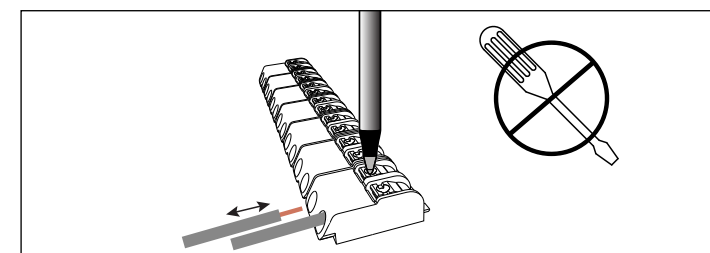

### 3.1 | Attach to the control panel

Use the control panel terminals labeled R, Y, G, B (PWR, A, B, COM). Connect them to the keypad terminals labeled R, Y, G, B. You can connect keypads to the SDI2 data bus by parallel wire run from the control panel to each keypad, wire from keypad to keypad, or a combination of the two techniques. Refer to the following illustrations in this section.

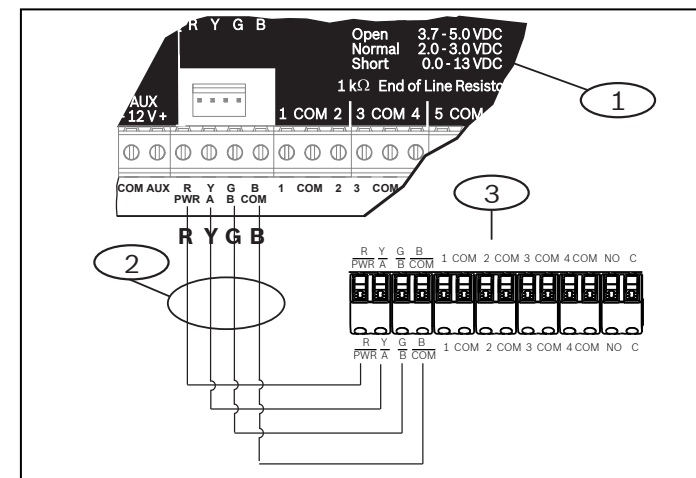

### Callout – Description

- |                                    |
|------------------------------------|
| 1 – Control panel                  |
| 2 – Terminal wiring                |
| 3 – Keypad's wiring terminal block |

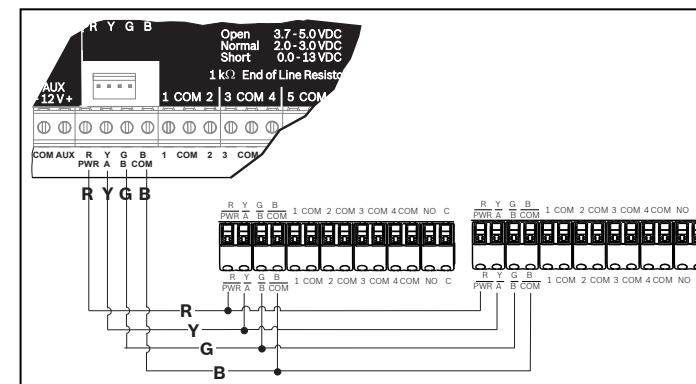

### 3.2 | Attach the inputs

Wire resistance on each sensor input must be less than 100 Ω with the detection devices connected. The terminal block supports 18 to 22 AWG (1.02 to 0.65 mm) wires. The keypad identifies open, short, normal, and ground fault circuit conditions on its sensor loops and transmits the conditions to the control panel individually. Run wires away from any telephone and AC wiring.

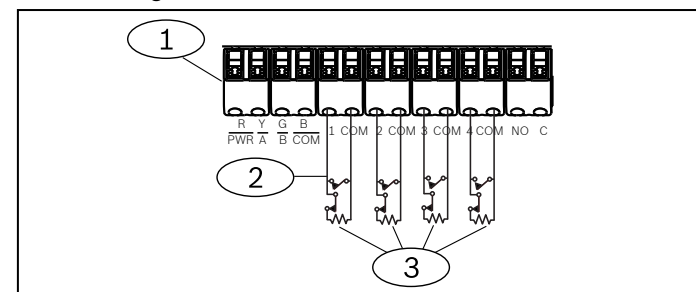

### Callout – Description

- |  |
|--|
| 1 – Keypad terminal strip              |
| 2 – Keypad sensor loops                |
| 3 – 1 kΩ EOL resistor (ICP-1K22AWG-10) |

## 3.3 | Attach the output

The keypad provides one NO (normally open) output. It includes NO and C (COMMON) terminals. When the output is active (energized), the NO has continuity with the C terminal.

**NOTICE!**  
Do not exceed relay contact ratings of 1.0 A, 24 VDC, resistive load.

## 3.4 | Install the keypad

1. Align the mounting hook openings over the hooks.
2. Push the keypad down.

## 4 | Set the address

Each SDI2 keypad must have a unique address. For single-digit addresses 1 through 9, set the tens switch to 0. The following illustration shows the address switch setting for address 1.

**NOTICE!**  
Only use your finger or a touch screen stylus on the keypad.

1. To show the start up screen, apply power to the keypad or push Time/Date for 5 seconds. You can also push anywhere on Call for Service screen.
2. Hold the countdown icon for 5 seconds to show the addressing page.
3. Use the up and down arrows to change the ones and tens digits.
4. Push **ESC** (Escape) to save the setting and return to the power up screen.

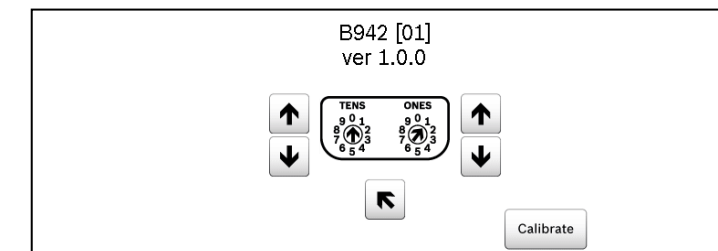

## 5 | Status indicators

Status indicator	Function
✓	Ready to turn on (arm)
🔒	Turned on (armed)
⚠️	System trouble
GAS	Gas alarm
🔌	AC power present

## 6 | Audible tones

The keypad has a built-in speaker that produces distinct warning tones.

Tone	Description
Fire alarm	Emits a pulsed, high-pitched bell tone.
Gas alarm	Emits a unique high pitched tone.
User alarm	The tone sounds for the programmed amount of time.
Burglary alarm	Emits a steady, high pitched bell tone.
Entry delay	Emits an intermittent beep tone during entry delay periods.
Exit delay	Emits an intermittent beep tone during exit delay.
Invalid button buzz	Emits a flat buzz tone.
Keypress	Emits a muted beep tone.
Trouble	Emits a two-tone warble until you enter a programmed passcode.
Watch point fault	Emits a single clean tweedle tone.

## 7 | Supervision

The control panel supervises all SDI2 devices. Any device that fails to respond will be declared missing.

## 8 | Proximity reader

The proximity reader allows users to use a token or card in place of a passcode to turn on or off the security system. The proximity reader supports EM4102 (125 kHz) credentials. The Bosch ACA-ATR13-RFID tag and Bosch ACD-ATR11ISO-RFID card are examples.

## 9 | Configure programmable keys functions

Use RPS to set the A,B,C Key Response parameters (KEYPADS/Global Keypad Settings) as follows:

- Fire key: set A Key Response to Manual fire alarm.
- Medical key: set B Key Response to Manual medical alarm (with or without alarm bell).
- Panic key: set C Key Response to Manual panic alarm (invisible or visible).

## 10 | Addresses, points, and output numbers

To determine the point numbers or output number for each keypad address, multiply the address number by 10 for the base number, and then use numbers 1 through 4 in the ones place for the point numbers. Use 1 in the ones place for the output number.

### Examples

For keypad address **01** the point numbers for the input devices are 11 through 14:

Terminal number	1	2	3	4
Input number	11	12	13	14

For output devices connected to the NO and C terminals the output number is 11.

For keypad address **11** the point numbers for the input devices are 111 through 114:

Terminal number	1	2	3	4
Point number	111	112	113	114

For output devices connected to the NO and C terminals the output number is 111.

## 11 | Firmware updates

Firmware updates require a MicroSD card (2 GB to 32 GB).

1. Go to [us.boschsecurity.com](https://us.boschsecurity.com).
2. Download the firmware from the B942 product page.
3. Save the firmware to your MicroSD card.
4. Make sure the keypad is powered.
5. Move the MicroSD card into the slot until it clicks into place.
6. Wait while the keypad shows *Please wait while programming flash*.
7. If the keypad shows the calibration screen, follow the on-screen instructions.
8. Remove the SD card when the keypad shows *Firmware update successful. Remove SD card to continue*.
9. Push down quickly on the card.
10. Use your fingernail on the upper groove on the card to push it out.
11. The keypad shows the power up screen with the updated revision number and then shows the Home screen.

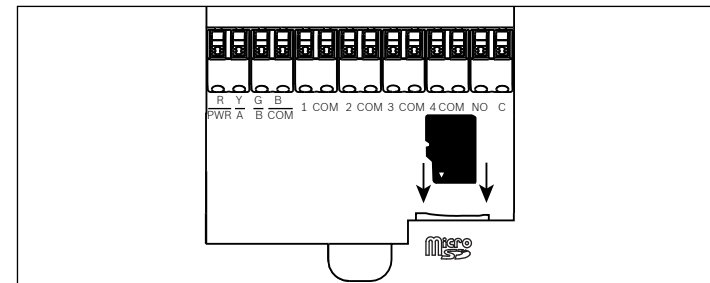

## 12 | Keypad cleaning

Use a soft cloth or a non-abrasive cleaning solution. Spray the cleaner onto the cloth, not the keypad.

## 13 | Certifications

Region	Certification
US	UL 1076 - Proprietary Burglar Alarm Units and Systems
	UL 1610 - Central Station Burglar Alarm Units
	CSFM - California Office of The State Fire Marshal
	FCC Part 15 Class B
	ANSI/SIA CP-01-2010 - Control Panel Standard - Features for False Alarm Reduction
CA	Canada CAN/ULC S303 - Local Burglar Alarm Units and Systems
	CAN/ULC S304 - Signal Receiving Centre and Premise Alarm Control Units
	CAN/ULC S545 - Residential Fire Warning System Control Units
	ULC-ORD C1023 - Household Burglar Alarm System Units
	ULC-ORD C1076 - Proprietary Burglar Alarm Units and Systems
	ICES-003 - Digital Apparatus

## 14 | Specifications

Dimensions	6.2 in x 4.7 in x 0.6 in (158 mm x 120 mm x 16 mm)
Voltage (input)	12 VDC nominal
Current with prox detection disabled	200 mA in standby mode 300 mA in alarm mode
Current with prox detection enabled	300 mA in standby mode 400 mA in alarm mode
Operating temperature	0°C to +50°C (+32°F to +122°F)

Relative humidity	5% to 93% at +32°C (+90°F) non-condensing
Terminal wire size	18 AWG to 22 AWG (1.02 mm to 0.65 mm)
SDI2 wiring with prox detector disabled	Maximum distance - wire size (unshielded wire only): 200 ft (61 m) - 22 AWG (0.65 mm) 520 ft (159 m) - 18 AWG (1.02 mm)
SDI2 wiring with prox detector enabled	Maximum distance - wire size (unshielded wire only): 150 ft (46 m) - 22 AWG (0.65 mm) 390 ft (119 m) - 18 AWG (1.02 mm)
Compatibility	B9512G/B9512G-E B8512G/B8512G-E B6512 B5512/B5512E firmware v2.03 and higher B4512/B4512E firmware v2.03 and higher B3512/B3512E firmware v2.03 and higher D9412GV4 firmware v2.03 and higher D7412GV4 firmware v2.03 and higher (Refer to the control panel installation document for number of supported devices.)

DE-de: Für Dokumentation in Ihrer Sprache, klicken Sie hier <https://de.boschsecurity.com/de>

EL-gr: Μεταβείτε στη διεύθυνση <https://gr.boschsecurity.com/el/> για την τεκμηρίωση σε αυτήν τη γλώσσα.

ES-es: Visite <https://es.boschsecurity.com/es/> para obtener documentación en este idioma.

FR-fr: Accédez à l'adresse <https://fr.boschsecurity.com/fr/> pour obtenir la documentation dans cette langue.

HU-hu: A honosított dokumentációt lásd a <https://hu.boschsecurity.com/hu/oldalok>.

IT-it: Andare a <https://it.boschsecurity.com/it/> per la documentazione in questa lingua.

NL-nl: Voor de documentatie in uw taal, ga naar <https://www.boschsecurity.com/nl/nl>

PL-pl: Dokumentacja w tym języku znajduje się w witrynie <https://pl.boschsecurity.com/pl/>

PT-br: Acesse <http://pt.boschsecurity.com/pt/> para obter a documentação neste idioma.

SE-sv: For documentation in this language, go to <https://www.boschsecurity.com/xn/en/>



**Touch Screen Keypad**  
B942/B942W



en Installation Guide

**Bosch Security Systems, B.V.**  
Torenallee 49  
5617 BA Eindhoven  
Netherlands  
[www.boschsecurity.com](http://www.boschsecurity.com)

### Copyright

This document is the intellectual property of Bosch Security Systems, Inc. and is protected by copyright. All rights reserved.

### Trademarks

All hardware and software product names used in this document are likely to be registered trademarks and must be treated accordingly.

### Bosch Security Systems, Inc. product manufacturing dates

Use the serial number located on the product label and refer to the Bosch Security Systems, Inc. website at <http://www.boschsecurity.com/datecodes/>.

