



# Installation & Operations Manual

RECOGNIZED COMPONENT



Intertek



## SmartRescue 5 & 10



Made in the USA  
3 Year Warranty

N56W24720 N. Corporate Circle • Sussex, WI 53089  
800-451-1460 • www.RATHCommunications.com

RP8500510  
Ver. 4  
11/19



Thank you for purchasing RATH's SmartRescue Base Station. We are the largest Emergency Communication Manufacturer in North America and have been in business for over 35 years.

We take great pride in our products, service, and support. Our Emergency Products are of the highest quality. Our experienced customer support teams are available to remotely assist with site preparation, installation, and maintenance. It is our sincere hope that your experience with us has and will continue to surpass your expectations.

Thank you for your business,

*The RATH® Team*

### Table of Contents

<b>SmartRescue 5 &amp; 10 Installation . . . . .</b>	<b>Page 3</b>
<b>Powering the SmartRescue . . . . .</b>	<b>Page 4</b>
<b>Wiring Emergency Phones to SmartRescue . . . . .</b>	<b>Page 5</b>
<b>Typical Wiring Diagrams for Elevators . . . . .</b>	<b>Pages 6-7</b>
<b>Typical Wiring Diagram for Areas of Refuge . . . . .</b>	<b>Page 8</b>
<b>Programming Options . . . . .</b>	<b>Pages 8-9</b>
<b>Operations &amp; Testing the System . . . . .</b>	<b>Pages 9-10</b>
<b>Maintenance . . . . .</b>	<b>Page 10</b>
<b>Machine Room Phone Installation &amp; Operation . . .</b>	<b>Page 11</b>
<b>SmartRescue System Activation Relay . . . . .</b>	<b>Page 11</b>
<b>Programming Phones into Consolidator Mode . . . .</b>	<b>Pages 11-12</b>
<b>Adjusting Volume on SmartPhones . . . . .</b>	<b>Page 12</b>
<b>Change Frequency of Phone Line Check . . . . .</b>	<b>Page 12</b>
<b>Troubleshooting . . . . .</b>	<b>Page 12</b>
<b>SmartRescue Specifications . . . . .</b>	<b>Page 13</b>
<b>Models &amp; Differences . . . . .</b>	<b>Page 13</b>
<b>SmartRescue Drawings . . . . .</b>	<b>Pages 14-15</b>

RECOGNIZED COMPONENT



Conforms to UL Standard 2017 for Attendant Monitored Signaling Devices  
Complies with Section 6.4 of UL 60950-1  
ETL Listing Number: 5013373

**Intertek**

**N56W24720 N. Corporate Circle • Sussex, WI 53089  
800-451-1460 • www.RATHCommunications.com**

# SmartRescue 5 & 10 Installation

## Pre-Installation Requirements

- 120v power
- Communication options (mandatory)
  - Dedicated analog phone line from POTS, PBX, central office, or digital phone line
  - Cellular (contact RATH® at 800-451-1460)
  - VoIP (contact RATH® at 800-451-1460)
- Twisted, shielded, 22 or 24 AWG, 2 pair wire cabling to connect each Emergency Phone to the SmartRescue
- RATH® 2100 Series SmartPhone(s)

## Installation Steps

### Step 1:

Remove the front cover from the SmartRescue and mount the SmartRescue back box to the wall using suitable mounting screws (not included).

### Step 2:

Punch out the conduit knockouts for the analog phone line and phone cabling runs.

### Step 3:

Connect an analog phone line to the outside phone line (**Diagram A**).

### Step 4:

Connect the backup battery cable to the battery terminal (battery included) (**Diagram A**).

**Note:** If using a 2300-630SM Machine Room Phone, see page 11.

**Diagram A**

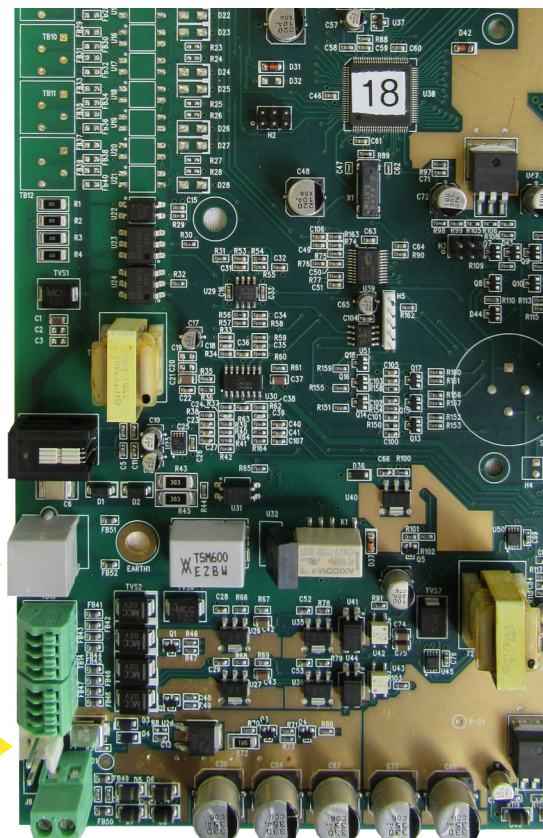

Connection from DEMARC  
or Analog Station Port on  
Internal Telephone System

Battery Backup  
Connection

# Powering the SmartRescue

## Step 5: Powering the SmartRescue

There are 3 options for powering the SmartRescue:

### Option 1: Plug-In Transformer (2500-205 & 2500-210 models only)

- Plug transformer into a standard 120vac outlet

### Option 2: Hard-Wired Transformer

- Connect the hot wire of the 120vac to the L screw
- Connect the neutral wire of the 120vac to the N screw
- Connect the ground wire of the 120vac to the ground screw
- Connect one lead of the dc power connection to the -V screw and the other to the +V screw
- Connect the other side of the dc power connection to the 24v power input on the lower left side of the SmartRescue (polarity is not important)

### Option 3: 2500-PWR24U Power Supply (Area of Refuge applications only)

- Use 1 pair, 18 AWG wire for power (maximum distance is 5,100')
- Connect one wire to the positive side of distribution block within the 2500-PWR24U, and the other wire to the negative side
- Connect the other side of wires to the 24v power input on the lower left side of the SmartRescue board (polarity is not important)

**Note:** Do not use the plug-in or hardwired transformer when using the 2500-PWR24U.

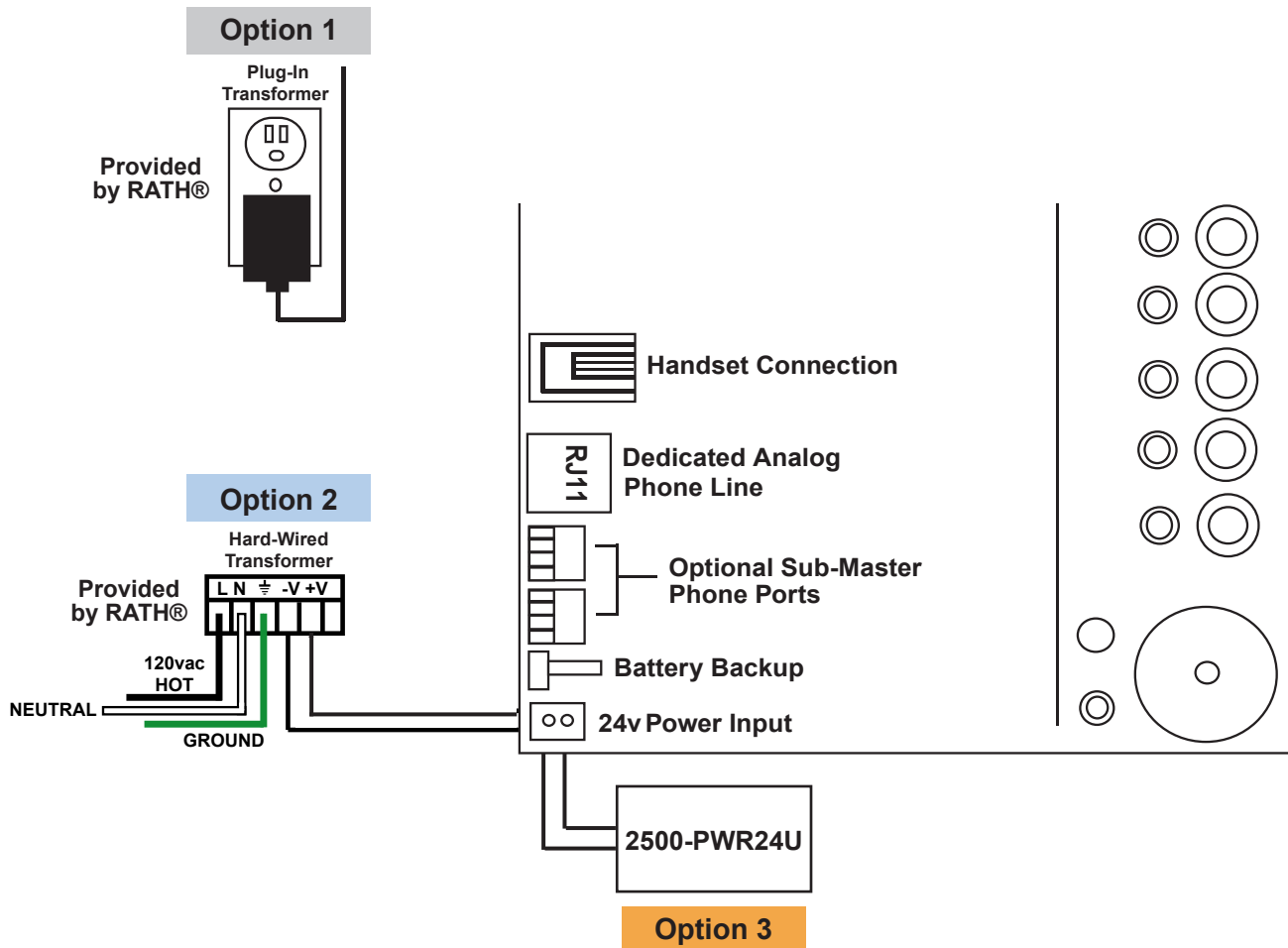

# Wiring Emergency Phones to SmartRescue

## Step 6: Wiring the Emergency Phones to the SmartRescue

Use twisted, shielded, 22 or 24 AWG, 2 pair cable between the phones and the SmartRescue. The maximum communication run is 5,100'.

### Connecting Wire Run:

**To SmartRescue:** Insert 4 wires for each phone as shown in **Diagram B**.

**To Phone:** Wire out to a standard 2 pair RJ11 connector. Pins 2 and 3 (red and green) carry the outside phone line. Pins 1 and 4 (yellow and black) are the intercom pair.

Diagram B

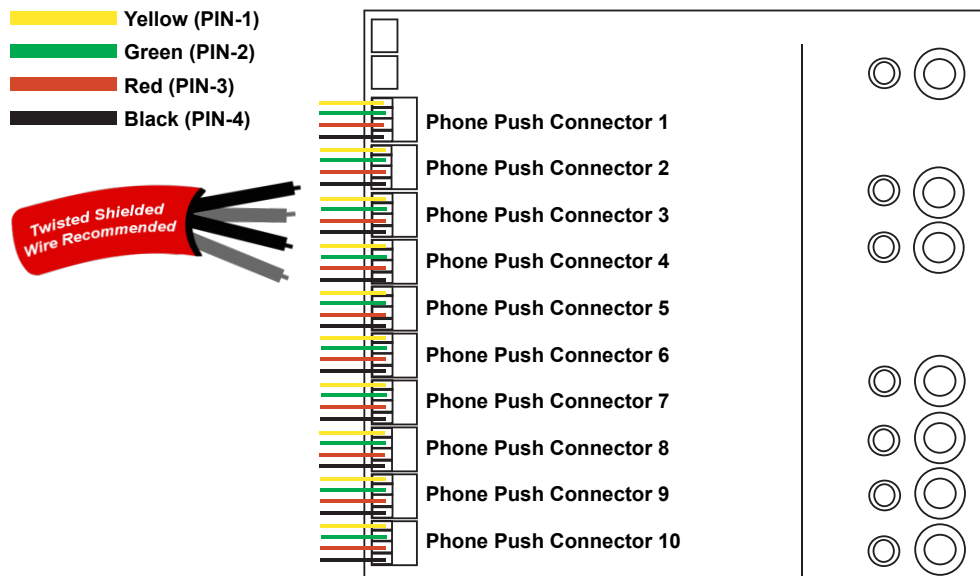

**Note:** When using the SmartRescue for Area of Refuge applications, it is recommended to use a biscuit jack for connecting each phone. This will prevent loose connections that can cause the system to malfunction. Biscuit jacks are available from RATH® by request.

**Note:** DO NOT use aluminum conductors with push-in terminals.

**Note:** Shields from the cabling runs (if used) should be attached to one of the mounting screws on the SmartRescue housing.

**Note:** Line impedance of the phone line is 600 ohms.

### Step 7:

Mount the front cover back on to the enclosure.

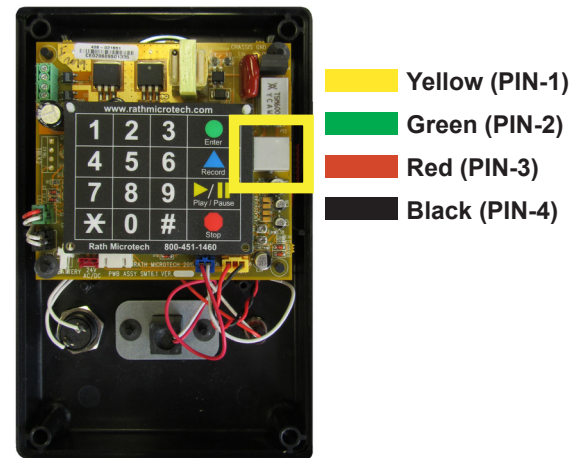

Emergency Phone

# Typical Wiring Diagrams for Elevator Applications

## Hard-Wired Transformer:

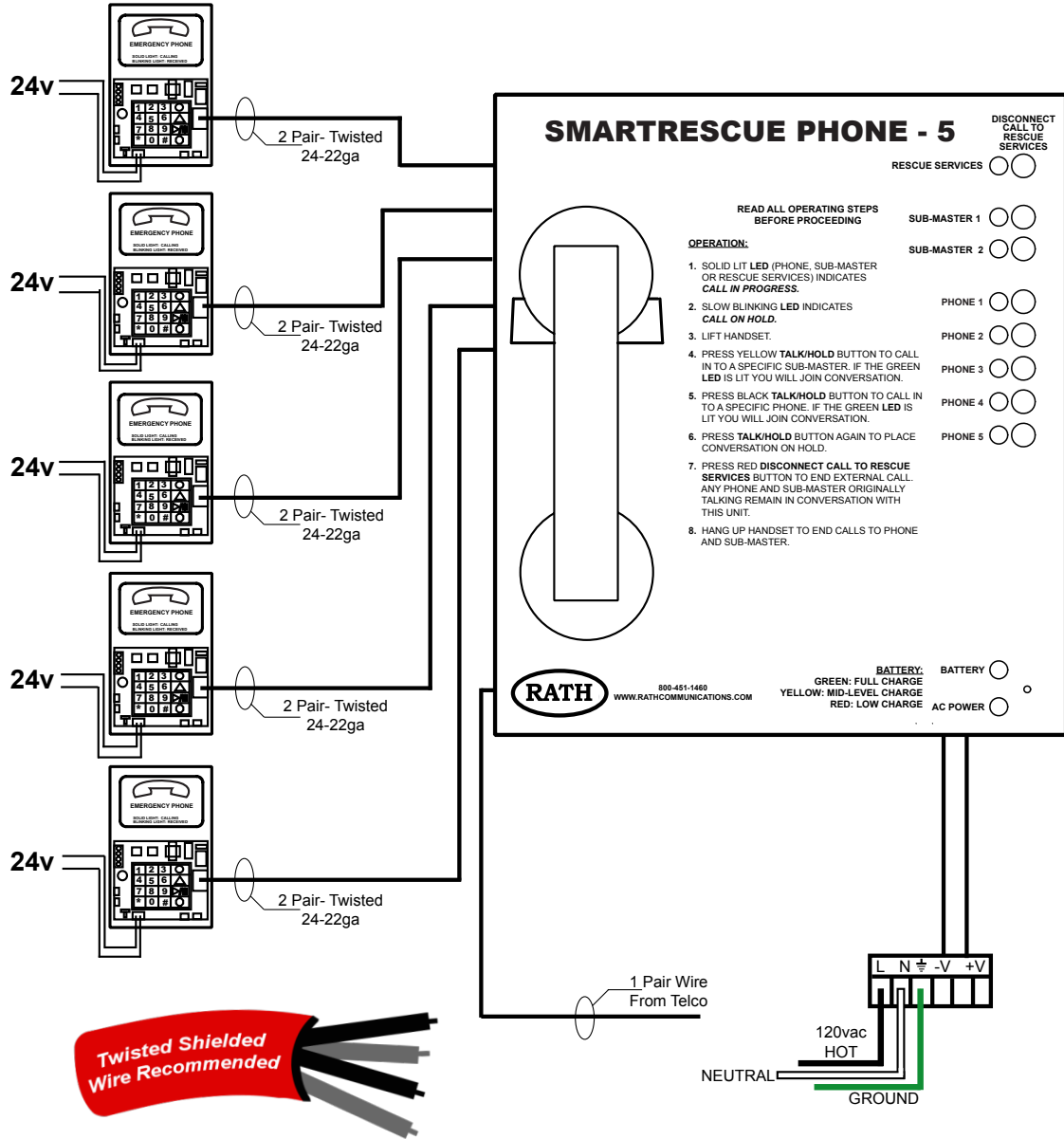

Connect 24vac or 24vdc from power source to power wiring harness on phone.  
The power connection is not polarity sensitive.

# Plug-In Transformer:

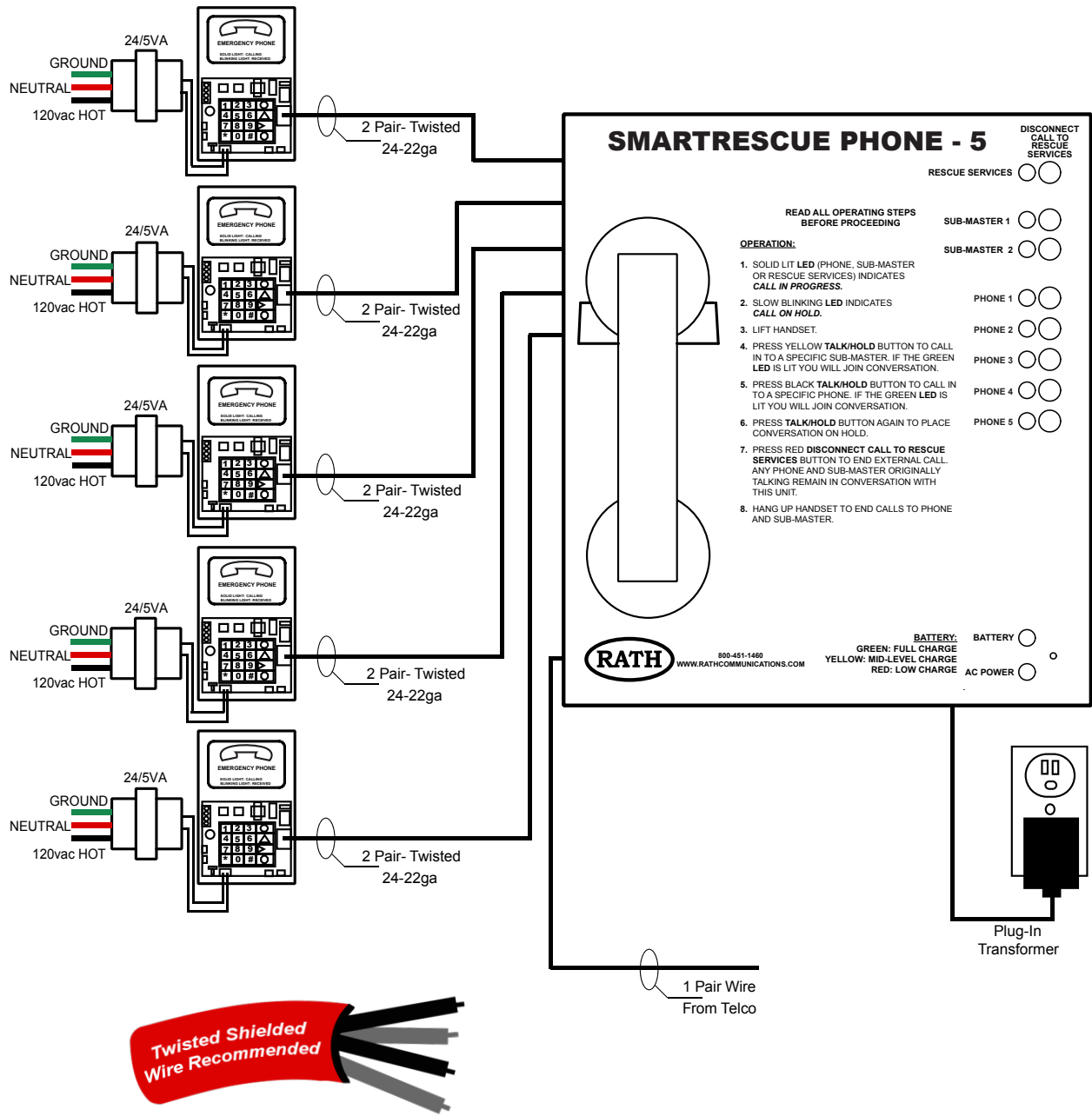

**Apply 120v to supplied transformer and connect the power wiring harness from the phone to the power output screws on the transformer. The 24v connection to phone is not polarity sensitive.**

# Typical Wiring Diagram for Area of Refuge Applications

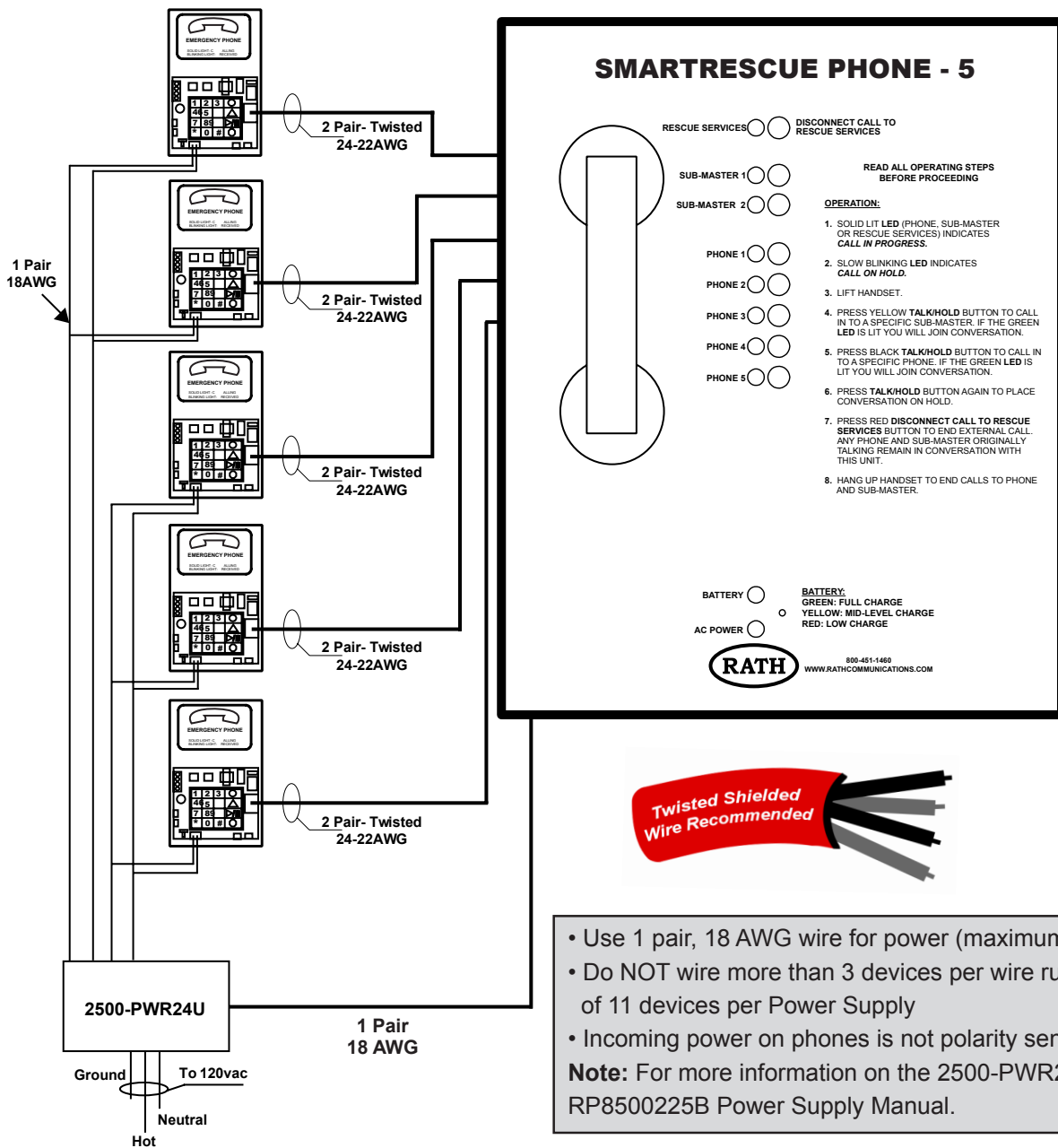

- Use 1 pair, 18 AWG wire for power (maximum distance is 5,100')
  - Do NOT wire more than 3 devices per wire run and a maximum of 11 devices per Power Supply
  - Incoming power on phones is not polarity sensitive
- Note:** For more information on the 2500-PWR24U, see the RP8500225B Power Supply Manual.

## Programming Options

### Step 8: Programming Options for SmartRescue

#### Option 1: Factory Default

The Emergency Phones will call directly offsite and not stop at the SmartRescue. That phone's button will light at the SmartRescue during the call.

**\*\*Keep in Default Mode if site is not manned 24/7 to answer calls onsite.**

#### Programming SmartRescue Back to Default Settings

1. Leave SmartRescue handset hung up.
2. Hold down red Disconnect and Sub-Master 1 buttons for 5 seconds
3. Release buttons (you will hear a confirmation tone)
4. Press Phone 2 button, then red button, then Sub-Master 2 button, and then the Phone 5 button
5. Press Sub-Master 2 button, then Sub-Master 1 button (you will hear a confirmation tone)



**Option 2:** Program the SmartRescue to Allow the Emergency Phones to call the SmartRescue First, then Outside Number(s)

1. Leave SmartRescue handset hung up
2. Hold down red Disconnect and Sub-Master 1 buttons for 5 seconds
3. Release buttons (you will hear a confirmation tone)
4. Press Phone 2 button, then red button, then the Phone 1 button
5. Press Sub-Master 2 button, then Sub-Master 1 button (you will hear a confirmation tone)

**\*\*Used when staff is available to answer calls.**

### Step 9: Programming the Emergency Phone(s)

**Option 1:** Call Emergency Numbers Offsite without Stopping at the SmartRescue

1. Press **Enter** to get into program mode
2. Press **1, Enter, (Emergency Number), Stop**
3. If using 2 emergency numbers, press **2, Enter, (Emergency Number), Stop**
4. Repeat for up to 5 total emergency numbers
5. To exit program mode, press and hold **Stop** for 2-3 seconds until warble sound

**Option 2:** Call SmartRescue First, if No Answer Call Emergency Numbers Offsite

1. Press **Enter** to get into program mode
2. Press **1, Enter, (Emergency Number), Stop**
3. Press **2, Enter,** (same **Emergency Number** as entered in b), **Stop**
4. To exit program mode, press and hold **Stop** for 2-3 seconds until warble sound

### **Program the Location Message:**

**Note:** This is always done, unless your Call Center requests it not to be.

1. Press **Enter** to get into program mode
2. To turn on message, press **1, 3, Enter, 2**
  - a. For no message, press **1, 3, Enter, 0**
3. Press **6, Record,** (wait for beep, speak your message), **Stop**
4. To program frequency of message, press **1, 3, Enter, \_\_\_**
  - 1 = Plays message once
  - 2 = Plays message twice (this is standard configuration)
  - 3 = Plays message until the called party presses \* on their phone
5. To exit program mode, press and hold **Stop** for 2-3 seconds until warble sound

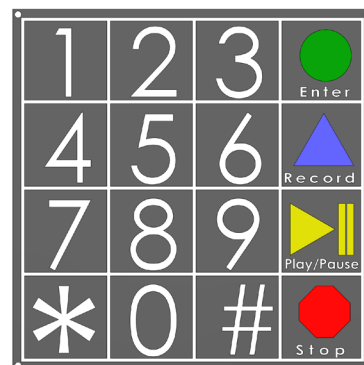

**\*\*The Elevator Industry REQUIRES the ability to call into each elevator from outside of the building. For instructions on how to put each phone into Consolidator Mode, see page 11.**

## ***Operations & Testing the System***

### **Step 10: Operating and Testing the System**

**1. Once all connections are made, the following LEDs should be lit:**

- Power LED, located on bottom edge of the face plate, will be constantly lit green.
- Battery LED, located on bottom edge of the face plate, will be constantly lit:
  - Red = Low level charge
  - Yellow = Mid level charge
  - Green = Full charge

**Note:** Battery may take up to 18 hours to fully charge.

## 2. Initiate a Call to an Emergency Phone or Machine Room Phone from the SmartRescue:

- a. Lift handset on SmartRescue.
- b. Press the Talk button for the corresponding Emergency Phone or Machine Room Phone you wish to call into.
- c. The green LED will light next to that button.
- d. You should have two-way communication to that phone.
- e. You can place the phone on hold by pressing the Talk button a second time.
- f. To resume communication, press the Talk button a third time.
- g. To disconnect, hang up the handset.

## 3. Emergency Phone Places a Call into the SmartRescue:

- a. You will hear an alternating audible tone at the SmartRescue indicating that a call has been initiated by one of the phones.
- b. The corresponding green LED will light on the SmartRescue next to the phone that placed the call.
- c. Lift the handset and there is two-way communication between the SmartRescue and the Emergency Phone. The handset can be hung up on the SmartRescue at any time to end the call.

**Note: If the call is answered at the SmartRescue, available ring on subsequent calls will not be heard until the system timer resets (1 minute).**

## 4. Emergency Phone Places a Call into the SmartRescue then an Outside Number, or just to an Outside Number:

- a. You will hear an alternating audible tone at the SmartRescue indicating that a call has been initiated by one of the phones (if programmed to call outside line only, no tone).
- b. The corresponding green LED will light on the SmartRescue next to the phone that placed the call.
- c. If call is not answered at the SmartRescue, the Emergency Phone will hang up and dial the second number programmed into the phone.
- d. The Rescue Services LED, located next to the red button, will also be lit indicating that the outside line is active. Two-way communication can then take place between the outside line and phone once the call is answered.
- e. The SmartRescue can join the conversation by lifting the handset.
- f. To talk to rescue services only from the SmartRescue, place the phone on hold by pressing the corresponding Talk button. To bring them back into the conversation, press the Talk button again.
- g. To disconnect rescue services, press the red button at the top of the face plate. The Rescue Services LED will go off and leave you communicating with the phones only.
- h. The handset on the SmartRescue can be hung up at any time to end the call.

***Testing for emergency communication should be done with the primary power source disconnected.***

***If the testing is completed and voice communication is clear, you have successfully installed the system.***

# Maintenance

## SmartRescue Maintenance

Under normal circumstances, the SmartRescue should be checked for proper operation annually. It is recommended to check the operation of the lights and indicators on the SmartRescue. To do this, pick up the handset on the SmartRescue to verify that the lights are working as intended and that the SmartRescue communicates with the attached phones. Periodic testing should be done with the primary power source disconnected.

## Battery Maintenance

Rechargeable batteries should be replaced every 3 years under normal circumstances. Contact RATH® for replacement batteries.

# Appendix

## 2300-630SM Machine Room Phone Installation & Operation

The 2300-630SM is an optional Machine Room Phone that may be remote mounted and used to call any of the phones connected to the SmartRescue. Up to (2) 2300-630SM phones may be connected to one SmartRescue.

**Note:** Machine Room Phones will only ring if they are being called by the SmartRescue.

### Installation:

- Mount the Machine Room Phone to the wall in desired location
- Run twisted, 22 or 24 AWG, 4 wire cabling to connect the Machine Room Phone to the SmartRescue
- **Emergency Phones MUST be in Consolidator Mode (see below)**

### Operation:

- Lift handset
- To speak to individual phones connected to SmartRescue:

Press *1 (Phone 1)	Press #1 (Phone 6)
Press *2 (Phone 2)	Press #2 (Phone 7)
Press *3 (Phone 3)	Press #3 (Phone 8)
Press *4 (Phone 4)	Press #4 (Phone 9)
Press *5 (Phone 5)	Press #5 (Phone 10)

If you wish to speak to all phones, press \*0

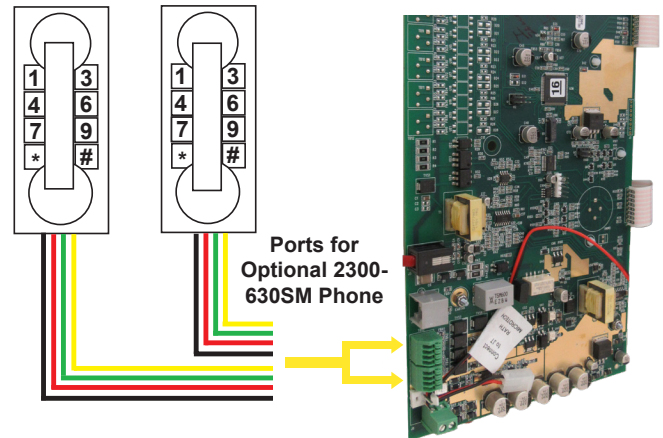

## SmartRescue System Activation Relay

When an Emergency Phone has been activated, this relay changes from NO to closed. It can be connected to a strobe or other notification means. Connection must be in the same room. See Specifications for load current and voltage (page 13).

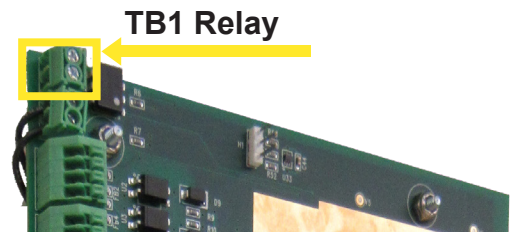

## Program Emergency Phones to Consolidator Mode (Elevator Industry Only)

Consolidator Mode allows you to have up to ten SmartPhones on a single telephone line and toggle between them from an outside call.

### Programming Steps

1. Press **Enter** to get into program mode
2. Press **7, Enter**
3. For Phones 1-5 press \*, 1-5

#### **Example:**

- For Phone 1: Press **7, Enter, \*, 1**
- For Phone 2: Press **7, Enter, \*, 2**

4. For Phones 6-10 press #, 1-5

#### **Example:**

- For Phone 6: Press **7, Enter, #, 1**
- For Phone 7: Press **7, Enter, #, 2**

5. To exit program mode, press and hold **Stop** for 2-3 seconds until warble sound
6. Confirm operation by calling the phone number that the phones are installed on; all phones will answer To speak to individual phones:
  - For phones 1-5 press **\*1, \*2, \*3, \*4, \*5**
  - For phones 6-10 press **#1, #2, #3, #4, #5**
  - To speak to all phones press **\*0**

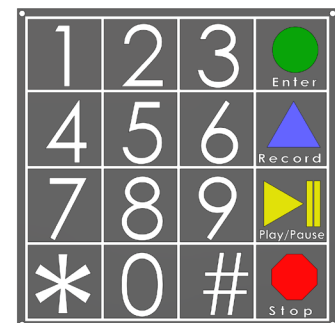

## Adjusting Volume on SmartPhone

1. Locate the silver VR1 POT on the bottom right corner of the SmartPhone board
2. Using a fine Philips Head screwdriver, turn the VR1 clockwise to increase the volume and counterclockwise to decrease the volume
3. The VR2 POT adjusts the microphone

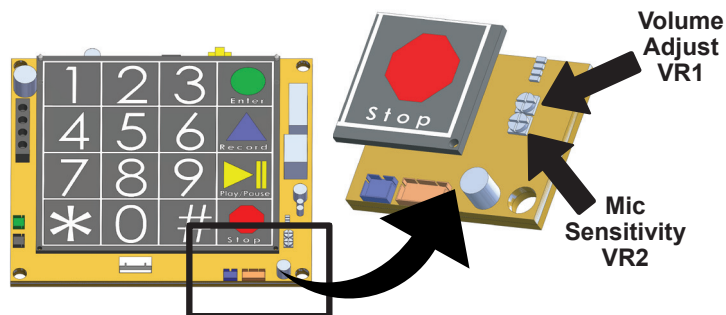

## Change Frequency of Phone Line Check using Onboard Keypad

1. Press **ENTER** to begin programming
2. Press **3, 4, ENTER**, 4 digit number in HH:MM

**Example:** 0020 = 20 minutes, 2300 = 23 hours

**Note:** The longest line check is once every 23 hours. The default setting is 10 minutes. To comply with UL 2017, the time must be set to 3 minutes.

3. Press and hold **STOP** for 3 seconds to exit programming

## Troubleshooting

Problem	Possible Cause & Solutions
Power LED is not illuminated:	<ul style="list-style-type: none"> <li>• Check to make sure the power being used has 24v going into the phone.</li> <li>• Make sure power connection on the circuit board is secure.</li> </ul>
Battery LED is not illuminated or always shows red:	<ul style="list-style-type: none"> <li>• Battery has not charged for long enough. Wait 18 hours for the battery to trickle charge. When fully charged it will have 19v.</li> <li>• Battery plug is not connected to circuit board. Verify connection.</li> <li>• Battery is worn. It is recommended to replace the battery every 2 years.</li> </ul>
LEDs on SmartPhone flash when button is pressed:	<ul style="list-style-type: none"> <li>• Verify the phone line is working and is connected properly.</li> <li>• Verify dial tone is present at the phones.</li> </ul>
Sub-Master and phone LEDs blinking on SmartRescue:	<ul style="list-style-type: none"> <li>• Verify power is applied and the backup battery is connected properly to the SmartRescue board.</li> </ul>
SmartRescue LEDs stay on:	<ul style="list-style-type: none"> <li>• Wires may be crossed. Verify wiring from the SmartRescue to the SmartPhone is correct.</li> </ul>
Two-way communication from SmartPhone is poor:	<ul style="list-style-type: none"> <li>• There could be feedback on the line. Adjust the VR1 and VR2.</li> <li>• Verify wiring is not spliced onto the phone line cord.</li> </ul>
SmartRescue will not dial phones:	<ul style="list-style-type: none"> <li>• Verify intercom wires (yellow and black) are connected properly from the SmartRescue to the SmartPhones. They should be on pins 1 and 4.</li> </ul>
SmartRescue will dial phone but phones will not dial SmartRescue:	<ul style="list-style-type: none"> <li>• No outside phone line connected to SmartRescue.</li> <li>• Phone line connected does not have working 24v to 52v.</li> <li>• Line connected has voltage but does not have working dial tone.</li> <li>• Plug analog phone into phone line and place a call out to verify line.</li> </ul>
No sound or tone on SmartRescue handset:	<ul style="list-style-type: none"> <li>• Verify 24v power is connected to the SmartRescue.</li> <li>• Verify that the volume dial on handset is not turned down.</li> </ul>
Dial tone is present on SmartRescue handset and phone is not calling out:	<ul style="list-style-type: none"> <li>• There should not be a dial tone on the SmartRescue handset.</li> <li>• Wire pairs are out of order. Verify wire pairs are connected to the correct pins.</li> <li>• Wires are shorted and need to be replaced.</li> </ul>

# SmartRescue Specifications

Conforms to UL STD 2017

## Type of Signaling:

- Emergency Signaling, TYPE AM

## Protection:

- Short Circuit/Overload/Over Voltage

## Ratings for SmartRescue Base Stations:

- Input Ratings: 100-120vac, 50/60Hz, 4.0A or 200-240vac, 50/60Hz, 2.0A when powered by 2500-PWR24U
  - Output Rating: 24vdc, 5A
- Input Ratings: 100-240vac, 50/60Hz, 0.7A when powered by RP7300061
  - Output Rating: 24vdc, 1.1A
- Input Ratings: 100-240vac, 50/60Hz, 0.65A when powered by RP7300055
  - Output Rating: 24vdc, 1.04A

## Ratings for 2100 Series SmartPhones:

- 24vdc, 0.5A when powered by 2500-PWR24U
- 24vac, 5VA when powered by RP7300110

## Environmental:

- For indoor use only
- Operating temperature 32° F to 120° F (0° C to 49° C)

## TB1 Relay:

- Load Current: 130mA
- Load Voltage: 350vdc or vac

**Note:** Input power circuit, battery circuit, and phone circuits are supervised in accordance with UL 2017 Section 84.3.

## Rechargeable Battery Ratings:

### SmartPhone

- Voltage: 7.2V
- Max Circuit Current: 80mA
- Amp Hour Capacity: 1300mAh
- Expected Standby Time: 24 hours
- Replacement Part: RP7300110

### SmartRescue

- Voltage: 16.8V
- Max Circuit Current: 100mA
- Amp Hour Capacity: 1400mAh
- Expected Standby Time: 24 hours
- Replacement Part: RP7300109A

# Models & Differences

## SmartRescues

Model Number	5 Zone	10 Zone	Stainless Steel Enclosure	Powder Coated Steel Enclosure	Surface Mount	Flush Mount
2500-205D	X		X		X	
2500-210D		X	X		X	
2500-205PSS	X		X			X
2500-210PSS		X	X			X
2500-205B	X			X	X	
2500-210B		X		X	X	
2500-205FM	X			X		X
2500-210FM		X		X		X

# Drawings

## Surface Mount Stainless Steel

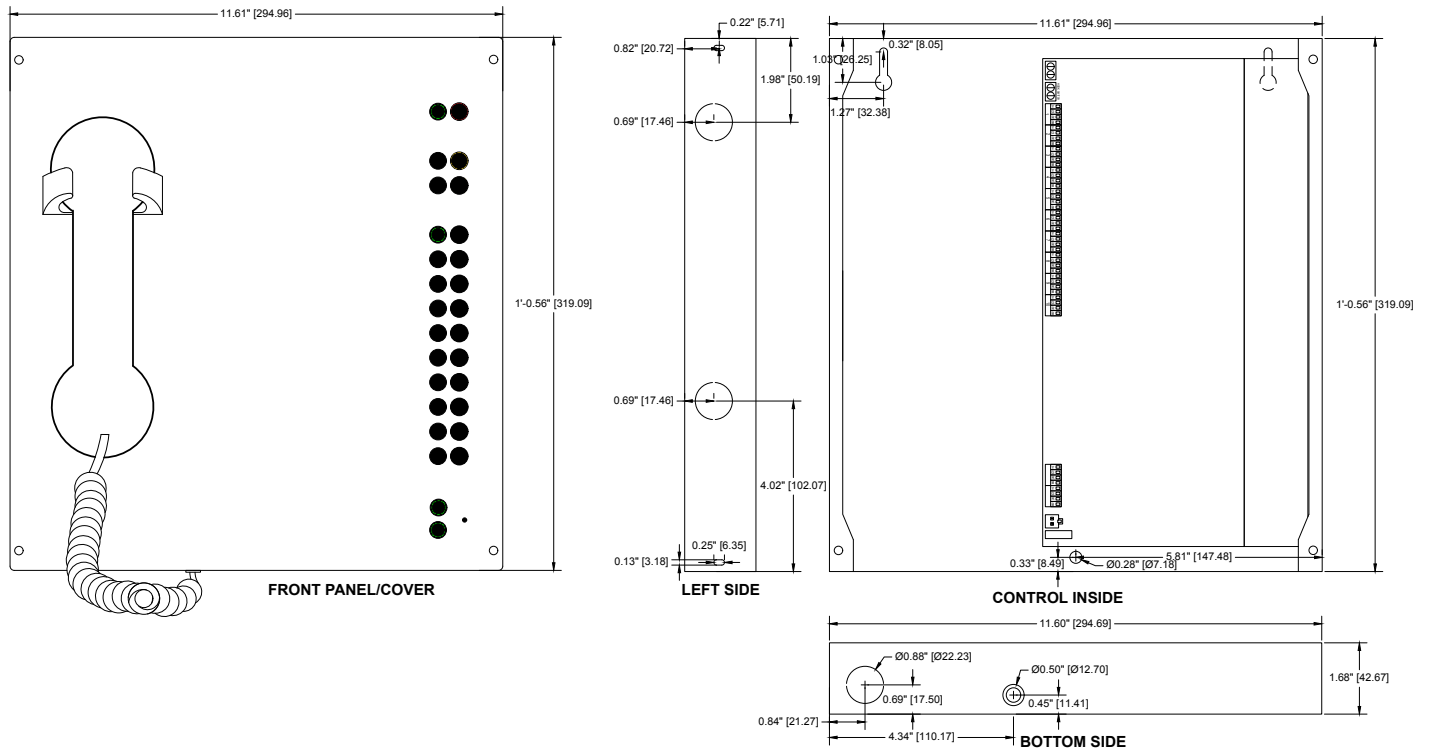

## Surface Mount Cabinet

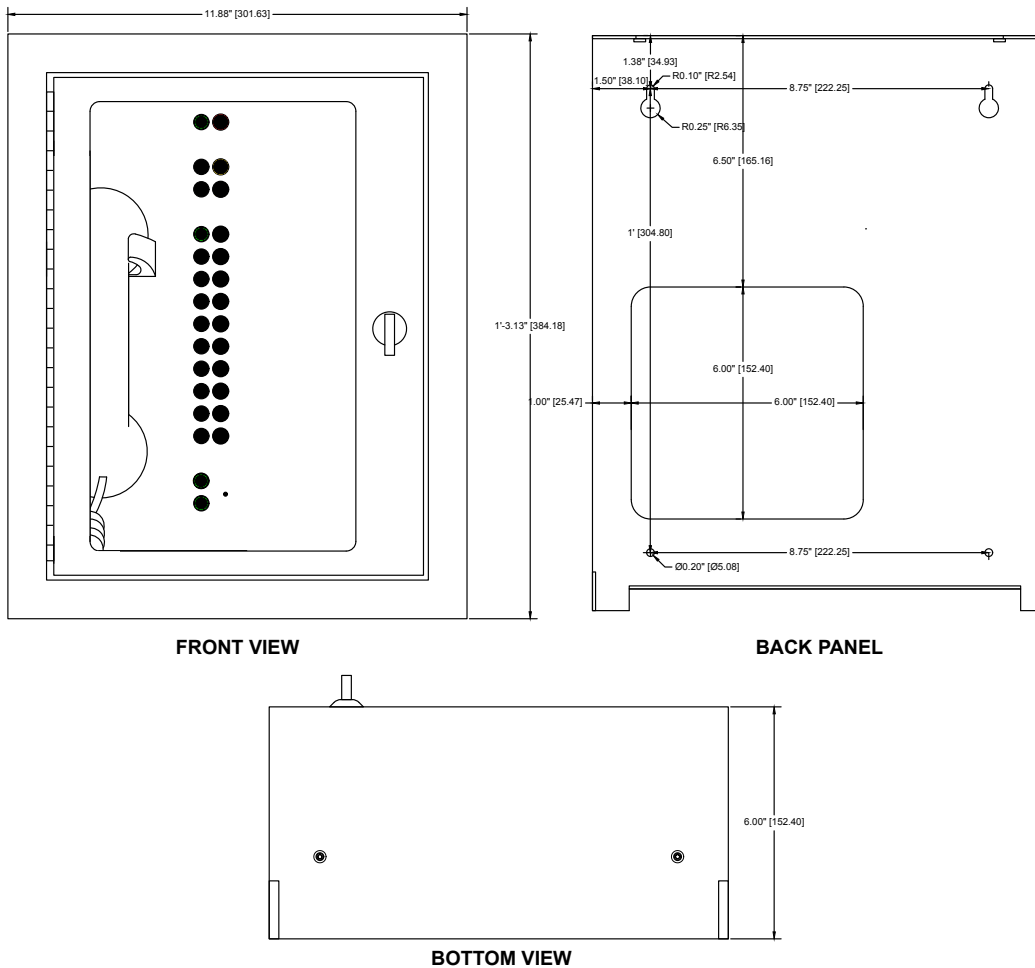

## Flush Mount Stainless Steel

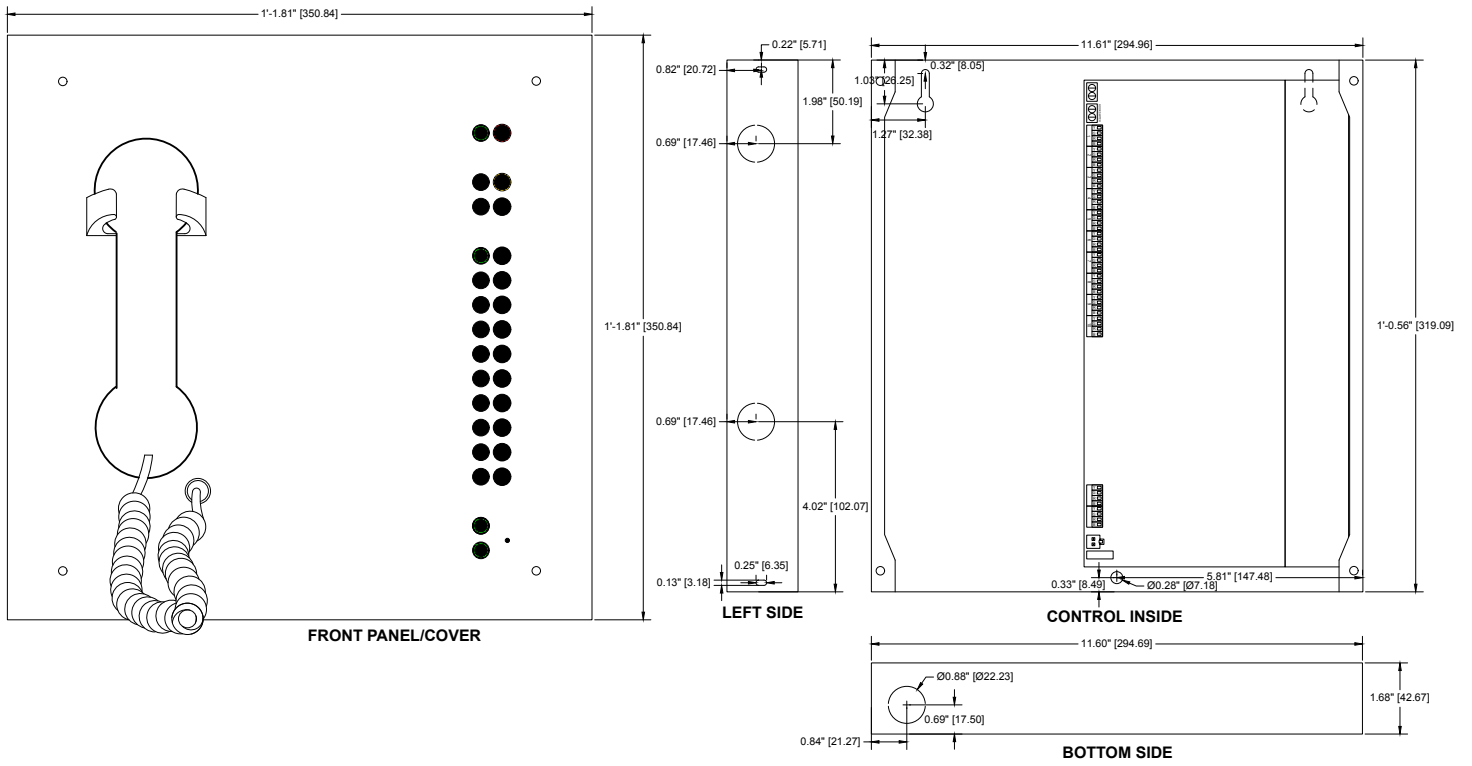

## Flush Mount Cabinet

