

WIRED ZONE EXPANDER/RELAY MODULE

INSTALLATION AND SETUP GUIDE

GENERAL INFORMATION

The ADEMCO 4229 Wired Zone Expander/Relay Module adds up to eight end-of-line resistor supervised zones and two dry form C (SPDT) relay outputs to compatible control communicators via the control's keypad wiring.

The module may be mounted within the control's cabinet (if room permits), or remotely. If mounted remotely, there are provisions to tamper-protect the unit. Communication to the module is supervised so that it cannot be disconnected from the keypad wiring without detection by the control. If the wiring is cut, a tamper or alarm signal will result, to indicate that this device (and possibly other similarly connected devices) has become inoperative.

IMPORTANT: Some carbon monoxide detectors may not be compatible with the ADEMCO 4229 hardwire zone expanders. When using carbon monoxide detectors in systems that support the 4229 zone expanders, install the detectors only on the basic hardwire zones of the system control panel, and NOT on the zone expanders.

INSTALLATION

When the module is to be mounted inside the control's cabinet, it should be mounted horizontally. Insert self-tapping screws (provided) in two adjacent raised tabs at the back of the cabinet. Leave the heads projecting 1/8". Hang the module on the screw heads via two of the slotted holes on the back of its housing. In this case, the module's cover need not be tamper protected. See the control's instructions for additional information.

When the module is to be mounted remotely, holes on its back permit it to be mounted horizontally or vertically. Wires can exit from the side or the breakout on the back of its housing. Place DIP switch #8 in the OFF position and, when the installation is completed, the module's cover put on. A magnet in the cover, positioned near a reed switch in the unit, will cause a tamper signal to be sent to the control if the cover is removed.

Affix the connections label that accompanies the unit to the inside of the module's cover (if the cover is to be used)) or to the inside of the control's cover

CONNECTIONS AND SETTINGS

See the table and the diagram on the reverse side. *Make protection zone connections to 12-position terminal block TB1. Each zone that is used must have a **2K ohm end-of-line resistor** connected across the end of its loop, as shown.*

If a zone is not programmed, the resistor need not be used. The method of programming each zone for type of alarm and reporting code to the central monitoring station varies with the control to which the module is connected. Refer to the installation instructions for that control unit.

Set the DIP switch to one of 31 addresses, as shown in the table on the reverse side, so the control can identify the module and communicate with it properly. The address to be set is determined by the particular control to be used, and the control's installation instructions must be consulted. As shipped, the DIP switch is set for an address of "0."

Zone A can be set for a fast response time of 10ms to an open circuit, if desired, by setting position 1 of the DIP switch to "OFF." As shipped, it is set to "ON" for a response time of 300ms, as shown in the table on the reverse side. All of the module's other protection zones have a nominal response time of 300ms.

Connections to the module's two relays are made via the 7-conductor cord provided. Refer to the control's installation instructions for specific information on how to program the control's various activation options for the relays.

Connections to the control's keypad wiring points can be made via 4-position terminal block TB2, the 4-pin plug, or both (wire color connections are the same)

SPECIFICATIONS

Physical	6-7/16"W x 4-1/4"H x 1-1/4"D (163mm x 108mm x 32mm)
Electrical	
Input Voltage:	12VDC (from control's remote keypad connection points)
Input Current:	30mA (relays off) 100mA (relays on)
Relay Contact Rating:	2A max. at 28VDC/AC

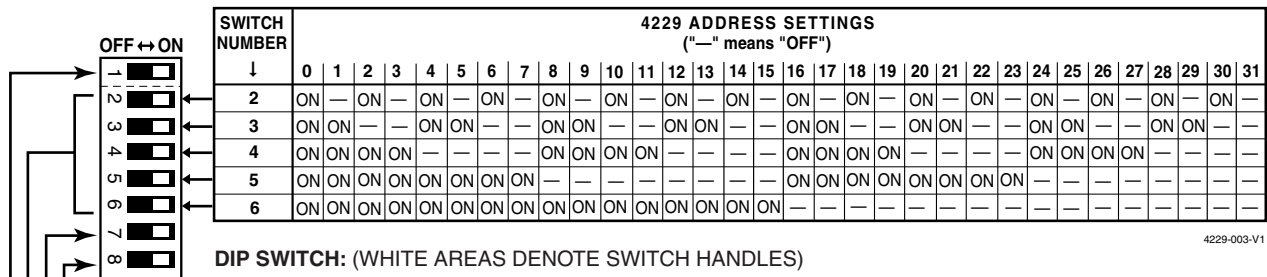

- DIP SWITCH:** (WHITE AREAS DENOTE SWITCH HANDLES)
- POSITION 8:** DIP SWITCH POSITION #8: CASE TAMPER ON = DISABLED OFF= ENABLED
 - POSITION 7:** DIP SWITCH POSITION #7: NOT USED LEAVE ON
 - POSITIONS 2-6:** DETERMINE ZONE EXPANDER'S ADDRESS. CONSULT CONTROL'S INSTRUCTIONS FOR ADDRESS USE. SWITCH SETTING SHOWN SET FOR ADDRESS "0".
 - POSITION 1:** DETERMINES ZONE A's RESPONSE TIME:
ON = NORMAL (300MS) RESPONSE, SHOWN (AS SHIPPED).
OFF = FAST (10MS) RESPONSE TO AN OPEN.

NOTE: ADDRESSES 16-31 MAY NOT BE AVAILABLE; CONSULT THE HOST CONTROL PANEL INSTALLATION INSTRUCTIONS.

EOLR value is 2K ohms.

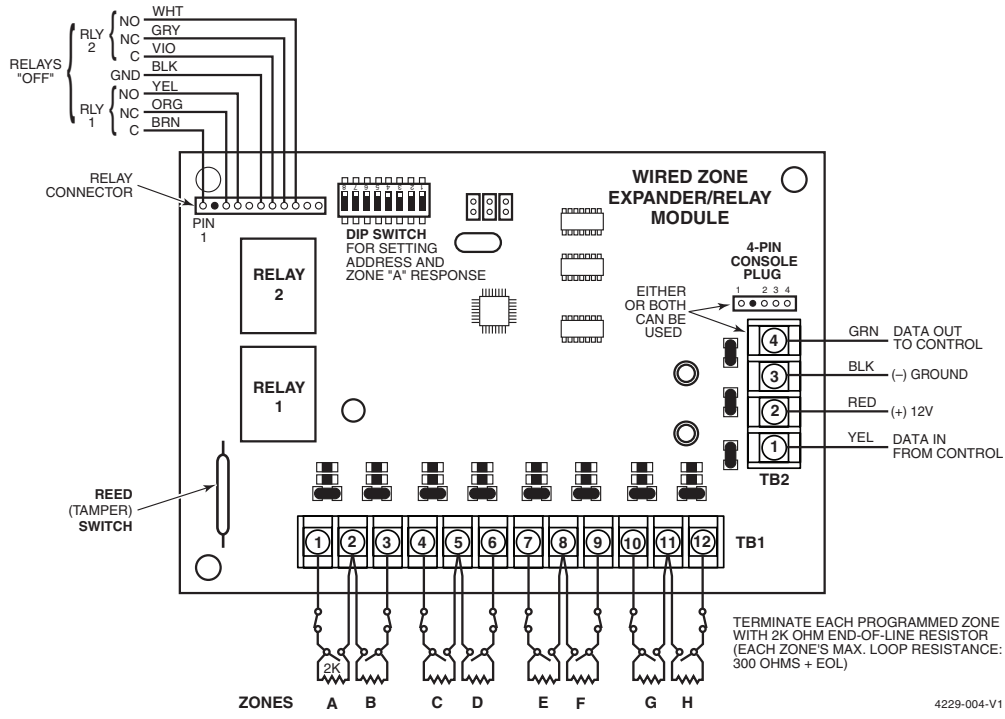

FOR LIMITATIONS OF THE ENTIRE ALARM SYSTEM, REFER TO THE INSTALLATION AND SETUP GUIDE FOR THE CONTROL PANEL WITH WHICH THIS DEVICE IS USED.

For the latest warranty information, please go to:
<http://www.security.honeywell.com/hsc/resources/wa>



2 Corporate Center Drive, Suite 100
P.O. Box 9040, Melville, NY 11747
Copyright © 2008 Honeywell International Inc.

