

Digital Series Distribution Board and Amplifiers DS-DB

Manual for the Digital Audio System



Fire Alarm & Emergency Communication System Limitations

While a life safety system may lower insurance rates, it is not a substitute for life and property insurance!

An automatic fire alarm system—typically made up of smoke detectors, heat detectors, manual pull stations, audible warning devices, and a fire alarm control panel (FACP) with remote notification capability—can provide early warning of a developing fire. Such a system, however, does not assure protection against property damage or loss of life resulting from a fire.

An emergency communication system—typically made up of an automatic fire alarm system (as described above) and a life safety communication system that may include an autonomous control unit (ACU), local operating console (LOC), voice communication, and other various interoperable communication methods—can broadcast a mass notification message. Such a system, however, does not assure protection against property damage or loss of life resulting from a fire or life safety event.

The Manufacturer recommends that smoke and/or heat detectors be located throughout a protected premises following the recommendations of the current edition of the National Fire Protection Association Standard 72 (NFPA 72), manufacturer's recommendations, State and local codes, and the recommendations contained in the Guide for Proper Use of System Smoke Detectors, which is made available at no charge to all installing dealers. This document can be found at <http://www.systemsensor.com/appguides/>. A study by the Federal Emergency Management Agency (an agency of the United States government) indicated that smoke detectors may not go off in as many as 35% of all fires. While fire alarm systems are designed to provide early warning against fire, they do not guarantee warning or protection against fire. A fire alarm system may not provide timely or adequate warning, or simply may not function, for a variety of reasons:

Smoke detectors may not sense fire where smoke cannot reach the detectors such as in chimneys, in or behind walls, on roofs, or on the other side of closed doors. Smoke detectors also may not sense a fire on another level or floor of a building. A second-floor detector, for example, may not sense a first-floor or basement fire.

Particles of combustion or "smoke" from a developing fire may not reach the sensing chambers of smoke detectors because:

- Barriers such as closed or partially closed doors, walls, chimneys, even wet or humid areas may inhibit particle or smoke flow.
- Smoke particles may become "cold," stratify, and not reach the ceiling or upper walls where detectors are located.
- Smoke particles may be blown away from detectors by air outlets, such as air conditioning vents.
- Smoke particles may be drawn into air returns before reaching the detector.

The amount of "smoke" present may be insufficient to alarm smoke detectors. Smoke detectors are designed to alarm at various levels of smoke density. If such density levels are not created by a developing fire at the location of detectors, the detectors will not go into alarm.

Smoke detectors, even when working properly, have sensing limitations. Detectors that have photoelectronic sensing chambers tend to detect smoldering fires better than flaming fires, which have little visible smoke. Detectors that have ionizing-type sensing chambers tend to detect fast-flaming fires better than smoldering fires.

Because fires develop in different ways and are often unpredictable in their growth, neither type of detector is necessarily best and a given type of detector may not provide adequate warning of a fire.

Smoke detectors cannot be expected to provide adequate warning of fires caused by arson, children playing with matches (especially in bedrooms), smoking in bed, and violent explosions (caused by escaping gas, improper storage of flammable materials, etc.).

Heat detectors do not sense particles of combustion and alarm only when heat on their sensors increases at a predetermined rate or reaches a predetermined level. Rate-of-rise heat detectors may be subject to reduced sensitivity over time. For this reason, the rate-of-rise feature of each detector should be tested at least once per year by a qualified fire protection specialist. Heat detectors are designed to protect property, not life.

IMPORTANT! Smoke detectors must be installed in the same room as the control panel and in rooms used by the system for the connection of alarm transmission wiring, communications, signaling, and/or power. If detectors are not so located, a developing fire may damage the alarm system, compromising its ability to report a fire.

Audible warning devices such as bells, horns, strobes, speakers and displays may not alert people if these devices are located on the other side of closed or partly open doors or are located on another floor of a building. Any warning device may fail to alert people with a disability or those who have recently consumed drugs, alcohol, or medication. Please note that:

- An emergency communication system may take priority over a fire alarm system in the event of a life safety emergency.
- Voice messaging systems must be designed to meet intelligibility requirements as defined by NFPA, local codes, and Authorities Having Jurisdiction (AHJ).
- Language and instructional requirements must be clearly disseminated on any local displays.
- Strobes can, under certain circumstances, cause seizures in people with conditions such as epilepsy.
- Studies have shown that certain people, even when they hear a fire alarm signal, do not respond to or comprehend the meaning of the signal. Audible devices, such as horns and bells, can have different tonal patterns and frequencies. It is the property owner's responsibility to conduct fire drills and other training exercises to make people aware of fire alarm signals and instruct them on the proper reaction to alarm signals.
- In rare instances, the sounding of a warning device can cause temporary or permanent hearing loss.

A life safety system will not operate without any electrical power. If AC power fails, the system will operate from standby batteries only for a specified time and only if the batteries have been properly maintained and replaced regularly.

Equipment used in the system may not be technically compatible with the control panel. It is essential to use only equipment listed for service with your control panel.

Telephone lines needed to transmit alarm signals from a premises to a central monitoring station may be out of service or temporarily disabled. For added protection against telephone line failure, backup radio transmission systems are recommended.

The most common cause of life safety system malfunction is inadequate maintenance. To keep the entire life safety system in excellent working order, ongoing maintenance is required per the manufacturer's recommendations, and UL and NFPA standards. At a minimum, the requirements of NFPA 72 shall be followed. Environments with large amounts of dust, dirt, or high air velocity require more frequent maintenance. A maintenance agreement should be arranged through the local manufacturer's representative. Maintenance should be scheduled as required by National and/or local fire codes and should be performed by authorized professional life safety system installers only. Adequate written records of all inspections should be kept.

Limit-D2-2016

Installation Precautions

Adherence to the following will aid in problem-free installation with long-term reliability:

WARNING - Several different sources of power can be connected to the fire alarm control panel. Disconnect all sources of power before servicing. Control unit and associated equipment may be damaged by removing and/or inserting cards, modules, or interconnecting cables while the unit is energized. Do not attempt to install, service, or operate this unit until manuals are read and understood.

CAUTION - System Re-acceptance Test after Software

Changes: To ensure proper system operation, this product must be tested in accordance with NFPA 72 after any programming operation or change in site-specific software. Re-acceptance testing is required after any change, addition or deletion of system components, or after any modification, repair or adjustment to system hardware or wiring. All components, circuits, system operations, or software functions known to be affected by a change must be 100% tested. In addition, to ensure that other operations are not inadvertently affected, at least 10% of initiating devices that are not directly affected by the change, up to a maximum of 50 devices, must also be tested and proper system operation verified.

This system meets NFPA requirements for operation at 0-49° C/ 32-120° F and at a relative humidity 93% ± 2% RH (non-condensing) at 32°C ± 2°C (90°F ± 3°F). However, the useful life of the system's standby batteries and the electronic components may be adversely affected by extreme temperature ranges and humidity. Therefore, it is recommended that this system and its peripherals be installed in an environment with a normal room temperature of 15-27° C/60-80° F.

Verify that wire sizes are adequate for all initiating and indicating device loops. Most devices cannot tolerate more than a 10% I.R. drop from the specified device voltage.

Like all solid state electronic devices, this system may operate erratically or can be damaged when subjected to lightning induced transients. Although no system is completely immune from lightning transients and interference, proper grounding will reduce susceptibility. Overhead or outside aerial wiring is not recommended, due to an increased susceptibility to nearby lightning strikes. Consult with the Technical Services Department if any problems are anticipated or encountered.

Disconnect AC power and batteries prior to removing or inserting circuit boards. Failure to do so can damage circuits.

Remove all electronic assemblies prior to any drilling, filing, reaming, or punching of the enclosure. When possible, make all cable entries from the sides or rear. Before making modifications, verify that they will not interfere with battery, transformer, or printed circuit board location.

Do not tighten screw terminals more than 9 in-lbs. Over-tightening may damage threads, resulting in reduced terminal contact pressure and difficulty with screw terminal removal.

This system contains static-sensitive components. Always ground yourself with a proper wrist strap before handling any circuits so that static charges are removed from the body. Use static suppressive packaging to protect electronic assemblies removed from the unit.

Units with a touchscreen display should be cleaned with a dry, clean, lint free/microfiber cloth. If additional cleaning is required, apply a small amount of Isopropyl alcohol to the cloth and wipe clean. Do not use detergents, solvents, or water for cleaning. Do not spray liquid directly onto the display.

Follow the instructions in the installation, operating, and programming manuals. These instructions must be followed to avoid damage to the control panel and associated equipment. FACP operation and reliability depend upon proper installation.

Precau-D2-11-2017

FCC Warning

WARNING: This equipment generates, uses, and can radiate radio frequency energy and if not installed and used in accordance with the instruction manual may cause interference to radio communications. It has been tested and found to comply with the limits for class A computing devices pursuant to Subpart B of Part 15 of FCC Rules, which is designed to provide reasonable protection against such interference when devices are operated in a commercial environment. Operation of this equipment in a residential area is likely to cause interference, in which case the user will be required to correct the interference at his or her own expense.

Canadian Requirements

This digital apparatus does not exceed the Class A limits for radiation noise emissions from digital apparatus set out in the Radio Interference Regulations of the Canadian Department of Communications.

Le present appareil numerique n'emet pas de bruits radio-electriques depassant les limites applicables aux appareils numeriques de la classe A prescrites dans le Reglement sur le brouillage radioelectrique edicte par le ministere des Communications du Canada.

HARSH™, NIS™, NOTI-FIRE-NET™, and eVance™ are all trademarks; and Acclimate® Plus™, FlashScan®, FAAST Fire Alarm Aspiration Sensing Technology®, Honeywell®, Intelligent FAAST®, NOTIFIER®, ONYX®, ONYXWorks®, SWIFT®, VeriFire®, and VIEW® are all registered trademarks of Honeywell International Inc. Microsoft® and Windows® are registered trademarks of the Microsoft Corporation. Chrome™ and Google™ are trademarks of Google Inc.

©2019 by Honeywell International Inc. All rights reserved. Unauthorized use of this document is strictly prohibited.

Software Downloads

In order to supply the latest features and functionality in fire alarm and life safety technology to our customers, we make frequent upgrades to the embedded software in our products. To ensure that you are installing and programming the latest features, we strongly recommend that you download the most current version of software for each product prior to commissioning any system. Contact Technical Support with any questions about software and the appropriate version for a specific application.

Documentation Feedback

Your feedback helps us keep our documentation up-to-date and accurate. If you have any comments or suggestions about our online Help or printed manuals, you can email us.

Please include the following information:

- Product name and version number (if applicable)
- Printed manual or online Help
- Topic Title (for online Help)
- Page number (for printed manual)
- Brief description of content you think should be improved or corrected
- Your suggestion for how to correct/improve documentation

Send email messages to:

FireSystems.TechPubs@honeywell.com

Please note this email address is for documentation feedback only. If you have any technical issues, please contact Technical Services.

Table of Contents

Section 1: General Information	7
1.1: Overview.....	7
1.2: Standards and Other Documents	7
1.3: Supplemental Documentation.....	8
1.4: Cautions and Warnings	8
Section 2: Digital Series Distribution Board - DS-DB	9
2.1: Description.....	9
2.1.1: Features.....	9
DS-DB	9
2.1.2: Specifications.....	9
24 VDC Input, TB24	9
Digital Audio Ports A and B - TB18, TB19	9
Alarm Bus - TB26.....	10
FFT Riser - TB25.....	10
DS-BUS - TB17.....	10
AUDIO OUT - TB1 through TB8.....	10
Primary and Backup 1 through 4 - TB9 through TB16	10
OUT 1 through 4 - TB20 through TB23.....	10
2.1.3: Digital Series Board Layouts.....	11
DS-DB Layout	11
Fiber Conversion Module	15
2.2: Installation	15
2.2.1: Cabinet.....	15
EQ Series Cabinets and Doors.....	15
CAB-4 Series	16
2.2.2: Wiring.....	17
Power to the DS-DB	17
24V Auxiliary Power - TB24.....	17
Alarm Bus - TB26.....	17
Digital Audio Ports A and B.....	18
FFT Riser Connections	20
DS-BUS, TB17.....	21
OUT 1 through 4, TB20 through TB23	23
Primary and Backup 1 through 4, TB9 through TB16	23
Speaker Circuits - Audio Out, TB1 through TB8.....	25
Wiring Fault Testing.....	28
UL Power-limited (Class 2) Wiring Requirements	29
2.3: Configuration.....	31
2.3.1: Address Switches, SW1, SW2.....	31
2.3.2: AMP1 - AMP4 Voltage Selection Switches, SW3 - SW6	31
2.3.3: Termination Switch, SW7	31
2.3.4: LOCSIL Local Silence Switch, SW9	31
2.3.5: Test Switch, SW10	32
2.3.6: 2Wire/4Wire Switch, SW12.....	32
2.4: Operation	32
2.4.1: Volume Control	32
2.4.2: FFT Communication.....	32
2.4.3: Trouble Messages	32
2.4.4: Read/Alter Status.....	32
Section 3: DS-AMP Digital Series Amplifiers.....	33
3.1: Description.....	33
3.2: Features.....	33
3.3: Specifications.....	33
AC POWER - TB4	33
BATTERY - TB5, TB6	33
HIGH LEVEL OUTPUT - TB3.....	33
AUDIO IN - TB2.....	33
DS-BUS	33
3.4: Layout.....	34
3.4.1: Connectors	34

3.4.2: Indicators	35
3.5: Installation	35
3.5.1: Cabinets	35
EQ Series Cabinets and Doors	36
3.5.2: Batteries, Installation	38
Within the CAB-4 Enclosure	38
Outside the DS-AMP Enclosure	38
3.5.3: Wiring	38
AC Power: TB4	38
Batteries, Wiring	39
DS-BUS: TB1	40
AUDIO IN: TB2	40
HIGH LEVEL OUTPUT: TB3	41
Wiring Fault Testing	41
UL Power Limiting (Class 2) Requirements	41
3.5.4: Address Switch - SW1	41
Section 4: DS-BDA Backup Amplifiers	42
4.1: Features	42
4.2: Specifications	42
DS-BDA card as backup	42
DS-BDA card as second channel	42
Audio In, TB1	42
Audio Out, TB2	42
4.3: Board Layout	43
4.4: Installation	44
DS-BDA Power and Control Cables	44
4.5: Wiring	45
Low Level Audio In: TB1	45
High Level Audio Out: TB2	45
Wiring Fault Testing	45
4.6: Operation	45
Section 5: DS-FM, DS-SFM and DS-RFM Fiber Option Modules	46
5.1: Specifications	46
5.2: Layout	47
5.3: Installation	48
5.4: Single- or Multi-mode DVC or DAA Installation	48
5.4.1: Single-mode	48
5.4.2: Multi-mode	49
Appendix A: DS-DB and DS-AMP Battery Calculations	50
Index	53

Section 1: General Information

1.1 Overview

This manual describes the DS-DB digital series distribution board and its amplifiers, which may be used as devices on a digital audio loop (DAL). They include:

- DS-DB digital series distribution boards, which connect directly to the DAL (digital audio loop). Each DS-DB occupies two of the 32 DAL addresses.
- DS-AMP amplifiers that connect to DS-DBs, and are addressable as part of the DS-DB subsystem.
- DS-BDA backup amplifiers, which connect to and back up DS-AMP amplifiers. They can also be used with the DS-DB subsystem as additional primary amplifiers.
- Fiber option modules, which convert DS-DB boards from wire to fiber, making the DS-DB compatible with other fiber DAL devices.

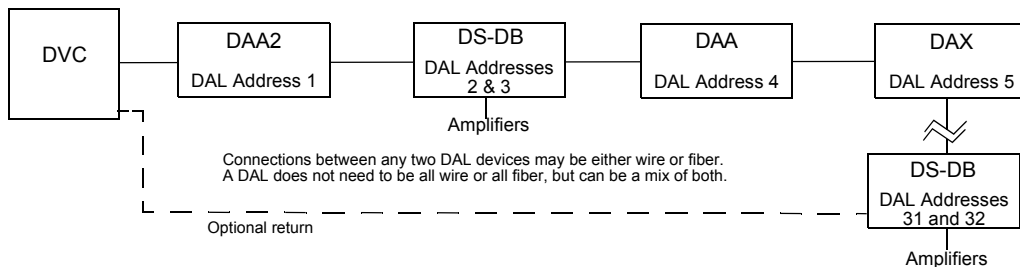

Figure 1.1 DAL (Digital Audio Loop) Block Diagram

Digital audio amplifiers are backed up by BDAs, or by another amplifier of the same digital type: that is, a DS-AMP must be backed up by a DS-BDA or another DS-AMP.

DAA2, DAX and DAA amplifiers are described in the DAA2/DAX manual listed in Table 1.1 on page 8.

1.2 Standards and Other Documents

The Digital Series products in this manual comply with the following standards:

- NFPA 72 National Fire Alarm Code
- Underwriter Laboratories Standard UL 864
- Underwriter Laboratories of Canada (ULC) ULC-S527 Standard of Control Units for Fire Alarm Systems
- Part 15 Class A conducted and radiated emissions as required by the FCC
- UL 2572 Mass Notification Systems Standard

The installer should be familiar with the following documents and standards:

NFPA Standards

NFPA 72 National Fire Alarm Code

Underwriter Laboratories

UL 464 Audible Signaling Appliances

UL 864 Standard for Control Unit and Accessories for Fire Alarm Systems

UL 1481 Power Supplies for Fire Protective Signaling Systems

UL 1638 Visual Signaling Appliances - Private-Mode Emergency and General Utility Signaling

UL 1711 Amplifiers for Fire Protective Signaling Systems

UL 60950 Safety of Information Technology Equipment

UL 1971 Signaling Devices for the Hearing Impaired

Underwriters Laboratories of Canada (ULC)

ULC-S527 Standard of Control Units for Fire Alarm Systems

Other

FCC Part 15 Class A Conducted and Radiated Emissions

1.3 Supplemental Documentation

The table below provides a list of documents referenced in this manual, as well as documents for other compatible devices.

VeriFire Tools CD help file and CD pamphlet	xxxxx 51690
DVC Digital Audio Manual	52411
DAA2/DAX Digital Audio Amplifiers Manual	53265
Heat Dissipation for Cabinets with Digital Audio Products	53645
Wire Guide Addendum for Digital Audio Loops	52916ADD
Device Compatibility Document	15378
DVC-AO Audio Option Board Installation Document	52728
NFS2-3030 Listing Document	LS10006-051NF-E
NFS2-640 Listing Document	52741LD
AMPS-24 Manual	51907
ACPS-610 Addressable Power Supply Manual	53018
NCA-2 Network Control Annunciator Manual	52482
ONYXWorks Workstation Manual	52342
DAL Devices Product Information Sheet	52410
AA Series Audio Amplifier Manual	52526
ACS Annunciator Manual	15842
AFAWS Automatic Fire Alarm Warden Station	50705
CFFT-1 Chassis for FireFighter's Telephone	53289
FTM-1 Firephone Control Module	156-1391-02
ACT-4 Audio Coupling Transformer	53431
ACT-25 Audio Coupling Transformer	53432
ACT-70 Audio Coupling Transformer	53240
RM-1 Series Remote Microphones	51138
CAB-4 Series Cabinets Installation Instructions	15330
EQ-CAB Series Installation Instructions	53412
RSM-1A Residential Silence Module	156-006-000
AIM-1A Audible Isolation Module	156-006-002
CIM-2A/CSM-1A Isolator and Silencing Modules	156-2200-002
RPJ-1 Remote Paging Jack	15058
FPJ Firefighter's Phone Jack	15510

Table 1.1 Related Documentation Table

1.4 Cautions and Warnings

This manual contains cautions and warnings to alert the reader as follows:

**CAUTION:**

INFORMATION ABOUT PROCEDURES THAT COULD CAUSE PROGRAMMING ERRORS, RUNTIME ERRORS, OR EQUIPMENT DAMAGE.

**WARNING:**

INDICATES INFORMATION ABOUT PROCEDURES THAT COULD CAUSE IRREVERSIBLE DAMAGE TO THE CONTROL PANEL, IRREVERSIBLE LOSS OF PROGRAMMING DATA, OR PERSONAL INJURY.

Section 2: Digital Series Distribution Board - DS-DB

2.1 Description

The Digital Series Distribution Board (DS-DB) and its associated amplifiers, the DS-AMP/E and DS-BDA, provide bulk amplification capability to the Digital Voice Command (DVC) system, while retaining digital audio distribution capabilities. Up to four amplifiers can supply high-level risers spread throughout an installation.

The DS-DB converts digital audio to analog and routes it to audio amplifiers and optional backups. The amplifiers send back high-level audio, which the DS-DB routes to its risers. Control and status information passes between the DS-DB and its components via the DS-BUS. The DS-DB communicates with the rest of the digital audio system through the DAL (digital audio loop).

This section contains information about the DS-DB distribution board. DS-AMP and DS-BDA amplifiers are covered in Section 3 and 4 respectively.

2.1.1 Features

DS-DB

- Input capacity of four digital audio channels.
- Four DVC-AO-level audio outputs for connection to amplifiers in the same or an adjacent cabinet.
- Eight high-level audio inputs (four primary, four backup), capable of handling 125W of audio at $25V_{RMS}$ or 100W at $70.7V_{RMS}$ on each input.
- Four Class A/eight Class B high-level audio outputs, each of which can output all 125W at $25V_{RMS}$ or 100W at $70.7V_{RMS}$ from any one of the four high-level primary inputs or four high-level backup inputs.
- Two digital audio loop wire ports, which may be modified to single- or multi-mode fiber ports with fiber option modules.
- Local FFT riser, capable of acting as a connection on the digital FFT riser.
- DS-BUS interface to communicate with local bulk amplifiers and power supplies.
- Up to 106 seconds of standard quality backup digital message storage (from the VeriFire Tools message library, or created by the installer) for use in the event of communication loss with the DVC.
- Isolated alarm bus input, to be used for backup activation of alarm messages when normal communication with the DVC is lost.
- Audio output activation via network control-by-event equations resident within the DVC.
- Uploads and downloads via the DVC.
- 24 VDC input for local power.
- Works with AMPS-24 power supply and battery charger. (Refer to “Power to the DS-DB” on page 17 for version-specific applications.)

2.1.2 Specifications

24 VDC Input, TB24

0.6A alarm or standby.

Non-resettable.

Power-limited (Class 2) by the source, supervised.

Any device connected to TB24 must be installed in the same enclosure, or within the same room in conduit.

Recommended wiring: 12 - 18 AWG (3.31 mm² - 2.08 mm²).

Digital Audio Ports A and B - TB18, TB19

Refer to the Wiring Guide, p/n 52916ADD, for acceptable wire types.

EIA-485 format.

Power-limited (Class 2).

Refer to Section 5, “DS-FM, DS-SFM and DS-RFM Fiber Option Modules”, on page 46 for fiber connection information.

Alarm Bus - TB26

Power-limited (Class 2) by source.

Supervision provided by source.

Recommended wiring: 14-18 AWG twisted-pair.

Requires minimum 16VDC @ 20mA across the terminals to activate. Nominal 24VDC.

FFT Riser - TB25

Power-limited (Class 2) output.

Supervised.

Class A or Class B operation.

Class B 2-wire connections require a 3.9k ohm 1/2 watt resistor (P/N R-3.9K (included)).

Max. wiring resistance (including individual telephone zone to last handset) permitted is 50 ohms, 10,000 ft. (3048 m)
max. wiring distance at 14 AWG to last handset.

DS-BUS - TB17

EIA-485 connection.

Power-limited (Class 2).

DS-BUS points must be installed in the same enclosure or within the same room in conduit.

DS-BUS end points require end-of-line resistors.

- DS-DB endpoint: Set SW7 (Termination) to "ON".
- DS-AMP endpoint: Add 120 ohm resistor (ELR P/N 71244) on empty TB1 terminals.
- AMPS-24* endpoint: resistor is present, and power supply must be an endpoint.

*AMPS-K2 version only - refer to "Power Harness Connector - J9" on page 17 for version identification.

Use 14 - 18 AWG, twisted unshielded wire.

AUDIO OUT - TB1 through TB8

Power-limited outputs (Class 2).*

* Exception: An output programmed for "Riser Mode to Control Modules", "Riser Mode to RSM-AIM Series Modules", or "Riser Mode to CIM/CSM Series Modules" is non-power-limited.

Up to 125 Watts output.

Supervision determined by programming.

25V_{RMS} or 70V_{RMS}, depending on amplifier setting. (Refer to Table 2.2, "DS-DB Switches," on page 14.)

Recommended wiring: 12-18 AWG twisted-pair (shielded recommended).

Class A or Class B operation.

Class B requires 20k end-of-line resistors (included, P/N ELR-20K).

Class A requires 10k end-of-line resistors (included, P/N R-10K) on the return.

Primary and Backup 1 through 4 - TB9 through TB16

Non-power-limited inputs.

Supervision programmable.

Amplifiers must be installed in the same enclosure or within the same room in conduit.

Recommended wiring: 14-18 AWG, twisted-pair, unshielded.

OUT 1 through 4 - TB20 through TB23

Power-limited (Class 2) outputs.

Supervision programmable.

Amplifiers must be installed in the same enclosure or within the same room in conduit.

Recommended wiring: 14-18 AWG, twisted-pair, unshielded.

2.1.3 Digital Series Board Layouts

DS-DB Layout

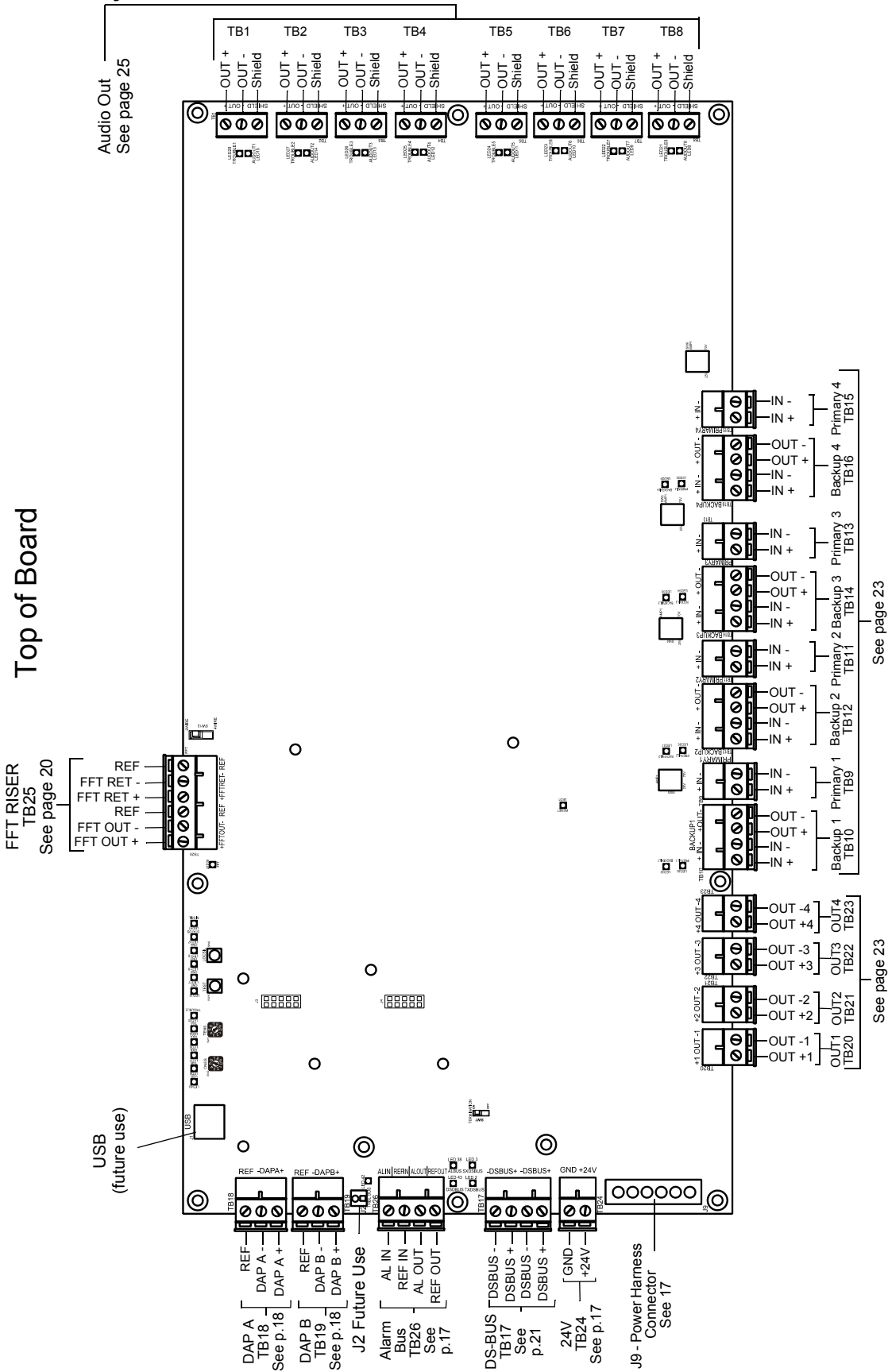

Figure 2.1 DS-DB Board Connections

LED #	NAME	COLOR	DESCRIPTION
1	RESET	Yellow	Illuminates when the board is not operational and maintenance is required. Call the factory.
2	TXDSBUS	Green	Illuminates when data is transmitted on the DS-BUS.
3	RXDSBUS	Green	Illuminates when data is received on the DS-BUS.
4	TXA	Green	Illuminates while data is transmitted on digital audio port A.
5	RXA	Green	Illuminates while data is received on digital audio port A.
6	TXB	Green	Illuminates while data is transmitted on digital audio port B.
7	RXB	Green	Illuminates while data is received on digital audio port B.
8	AUDOUT8	Green	Illuminates steadily while analog signal is on speaker circuit 8, or while 200Hz tone is on speaker circuit 8.
9	AUDOUT7	Green	Illuminates steadily while analog signal is on speaker circuit 7, or while 200Hz tone is on speaker circuit 7.
10	AUDOUT6	Green	Illuminates steadily while analog signal is on speaker circuit 6, or while 200Hz tone is on speaker circuit 6.
11	AUDOUT5	Green	Illuminates steadily while analog signal is on speaker circuit 5, or while 200Hz tone is on speaker circuit 5.
12	AUDOUT4	Green	Illuminates steadily while analog signal is on speaker circuit 4, or while 200Hz tone is on speaker circuit 4.
13	AUDOUT3	Green	Illuminates steadily while analog signal is on speaker circuit 3, or while 200Hz tone is on speaker circuit 3.
14	AUDOUT2	Green	Illuminates steadily while analog signal is on speaker circuit 2, or while 200Hz tone is on speaker circuit 2.
15	AUDOUT1	Green	Illuminates steadily while analog signal is on speaker circuit 1, or while 200Hz tone is on speaker circuit 1.
16	ON1	Green	Illuminates steadily while there is an analog signal on low level output 1, or while 200Hz tone is on low level output 1. Blinks while a download is in progress for the DS-AMP at address 1.
17	ON2	Green	Illuminates steadily while there is an analog signal on low level output 2, or while 200Hz tone is on low level output 2. Blinks while a download is in progress for the DS-AMP at address 2.
18	ON3	Green	Illuminates steadily while there is an analog signal on low level output 3, or while 200Hz tone is on low level output 3. Blinks while a download is in progress for the DS-AMP at address 3.
19	ON4	Green	Illuminates steadily while there is an analog signal on low level output 4, or while 200Hz tone is on low level output 4. Blinks while a download is in progress for the DS-AMP at address 4.
20	TROUBLE	Yellow	Blinks when there is an unacknowledged trouble, illuminates steadily when a trouble is acknowledged but unresolved.
21	TROUBLE8	Yellow	Illuminates steadily while a short is detected on speaker circuit 8. Blinks slowly (once a second) while an open is detected. Blinks fast (4 times a second) when this speaker circuit is disabled.
22	TROUBLE7	Yellow	Illuminates steadily while a short is detected on speaker circuit 7. Blinks slowly (once a second) while an open is detected. Blinks fast (4 times a second) when this speaker circuit is disabled.
23	TROUBLE6	Yellow	Illuminates steadily while a short is detected on speaker circuit 6. Blinks slowly (once a second) while an open is detected. Blinks fast (4 times a second) when this speaker circuit is disabled.
24	TROUBLE5	Yellow	Illuminates steadily while a short is detected on speaker circuit 5. Blinks slowly (once a second) while an open is detected. Blinks fast (4 times a second) when this speaker circuit is disabled.
25	TROUBLE4	Yellow	Illuminates steadily while a short is detected on speaker circuit 4. Blinks slowly (once a second) while an open is detected. Blinks fast (4 times a second) when this speaker circuit is disabled.

Table 2.1 DS-DB LED Indicators (1 of 2)

LED #	NAME	COLOR	DESCRIPTION
26	TROUBLE3	Yellow	Illuminates steadily while a short is detected on speaker circuit 3. Blinks slowly (once a second) while an open is detected. Blinks fast (4 times a second) when this speaker circuit is disabled.
27	TROUBLE2	Yellow	Illuminates steadily while a short is detected on speaker circuit 2. Blinks slowly (once a second) while an open is detected. Blinks fast (4 times a second) when this speaker circuit is disabled.
28	TROUBLE1	Yellow	Illuminates steadily while a short is detected on speaker circuit 1. Blinks slowly (once a second) while an open is detected. Blinks fast (4 times a second) when this speaker circuit is disabled.
29	BACKFAIL4	Yellow	Illuminates while backup audio amplifier 4 failure is detected.
30	BACKFAIL3	Yellow	Illuminates while backup audio amplifier 3 failure is detected.
31	BACKFAIL2	Yellow	Illuminates while backup audio amplifier 2 failure is detected.
32	BACKFAIL1	Yellow	Illuminates while backup audio amplifier 1 failure is detected.
33	PRIFAIL4	Yellow	Illuminates while primary audio amplifier 4 failure is detected.
34	PRIFAIL3	Yellow	Illuminates while primary audio amplifier 3 failure is detected.
35	PRIFAIL2	Yellow	Illuminates while primary audio amplifier 2 failure is detected.
36	PRIFAIL1	Yellow	Illuminates while primary audio amplifier 1 failure is detected.
37	STATUS	Green	Blinks slowly (once a second) under normal operation, Blinks fast (4 times a second) when the DS-DB is in bootload or diagnostic mode. Does not blink when the board is not operational or starting up. Call the factory if this LED is off for a prolonged period of time.
38	ALBUS	Red	Illuminates while the alarm bus input is activated.
39	FFT	Green	Illuminates when it has been granted a digital phone channel.
40	USB	Green	Future Use.
41	SIGSIL	Yellow	Illuminates when the local signal silence button has silenced one or more outputs.
42	TRBL BUS	Yellow	Illuminates when a trouble is detected by the Trouble bus input.
43	DSBUS	Yellow	Illuminates when one or more DS-BUS communication failures is present. The DS-DB is not communicating with one or more DS-AMPS or the power supply. An address-specific trouble DSBUS Communications Failure trouble is generated to the panel.

Table 2.1 DS-DB LED Indicators (2 of 2)

SWITCH #	NAME	DESCRIPTION	DEFAULT
1	TENS	DAL BCD rotary address tens selection switch.	0
2	ONES	DAL BCD rotary address ones selection switch.	0
3	AMP1	Slider switch for 25V/70V selection. This switch sets the Primary and Backup #1 pair.	70V
4	AMP2	Slider switch for 25V/70V selection. This switch sets the Primary and Backup #2 pair.	70V
5	AMP3	Slider switch for 25V/70V selection. This switch sets the Primary and Backup #3 pair.	70V
6	AMP4	Slider switch for 25V/70V selection. This switch sets the Primary and Backup #4 pair.	70V
7	TERMINATION	DS-BUS termination switch.	OFF
9	LOCSIL	Local signal silence pushbutton switch.	N/A
10	TEST	Clears the "TRIP" condition of all Primary and Backup amplifiers. See "Test Switch, SW10" on page 32 for more information.	N/A
12	2WIRE/4WIRE	Changes FFT Riser indication to 2- or 4-wire, depending on whether the riser is wired Class B or Class A.	2-wire

Table 2.2 DS-DB Switches

Fiber Conversion Module

A fiber conversion module will convert a DS-DB DAP port from wire to fiber. Refer to Section 5, “DS-FM, DS-SFM and DS-RFM Fiber Option Modules”, on page 46, for installation and application information.

2.2 Installation

2.2.1 Cabinet

The DS-DB arrives from the factory already installed on its chassis. The DS-DB chassis mounts in a CAB-4 Series cabinet, as well as in the EQCAB Series backboxes.

Prior to installation,

- Review the installation precautions at the front of this manual.
- Installers should be familiar with the standards and codes specified in “Standards and Other Documents” on page 7.
- Ensure all wiring will comply with national and local codes.
- Review the installation instructions in this section.



WARNING:

Wear a static discharge wrist strap to prevent equipment damage.



NOTE: Digital amplifiers can produce significant heat. Different cabinets can handle different amounts of heat. Refer to the Heat Dissipation Document (53645) to determine dissipation figures for the equipment you are installing, and match it with an appropriate cabinet.

Locate the cabinet backbox on a surface that is in a clean, dry, vibration-free area. The top should be located so that all operational buttons, switches, displays, etc. are easily accessible and/or viewable to the operator - usually no more than 66 inches (1.7 m) above the floor. Allow sufficient clearance around the cabinet for the door to swing freely, and for easy installation and maintenance of equipment.

Follow the instructions below.

1. Mark and pre-drill two holes for the keyhole mounting bolts. Install bolts.
2. Select and punch open the appropriate cabinet knock-outs. (For selection guidelines, see “UL Power-limited (Class 2) Wiring Requirements” on page 29.)
3. Using the keyholes, mount the backbox on the two bolts.
4. Mark the location of the two lower holes, remove backbox and drill the mounting holes.
5. Mount the backbox over the top two screws, then install the remaining fasteners. Tighten all fasteners securely.
6. Feed wires through appropriate knockouts.
7. Install DS-DB according to the following instructions before installing the door per the Cabinet Installation Document.

The DS-DB fills one row of any EQCAB, CAB-4, or CAB-3 series cabinet.

EQ Series Cabinets and Doors

The EQ Series cabinets come in B, C, and D sizes. The row spacing allows DS-DBs to be mounted in any row, and the doors are equipped with ventilated panels for heat dissipation. The cabinets were designed so that a DS-DB board can be used in any cabinet row.

The following models are available:

- EQCAB-D4 - Four rows. Accommodates DS-DB and three DS-AMPs. Consists of P/Ns EQBB-D4 (black backbox) and EQDR-D4 (black door with ventilated panels).
- EQCAB-C4 - Three rows. Accommodates DS-DB and two DS-AMPs. Consists of P/Ns EQBB-C4 (black backbox) and EQDR-C4 (black door with ventilated panels).

- EQCAB-B4 - Two rows. Accommodates DS-DB and one DS-AMP. Consists of P/Ns EQBB-B4 (black backbox) and EQDR-B4 (black door with ventilated panels).

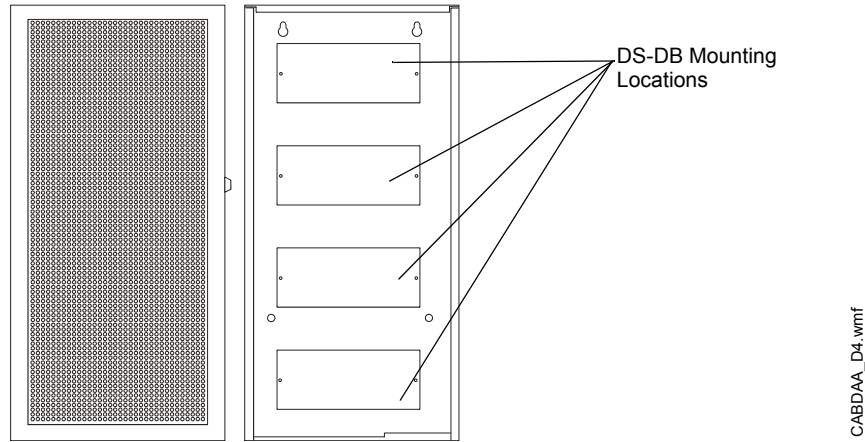

Figure 2.3 EQBB-D4 Backbox and EQDR-D4 Door

CAB-4 Series

Figure 2.4 illustrates a typical DS-DB installation. A DP-1B dress panel, ordered separately, can be used to cover the row.

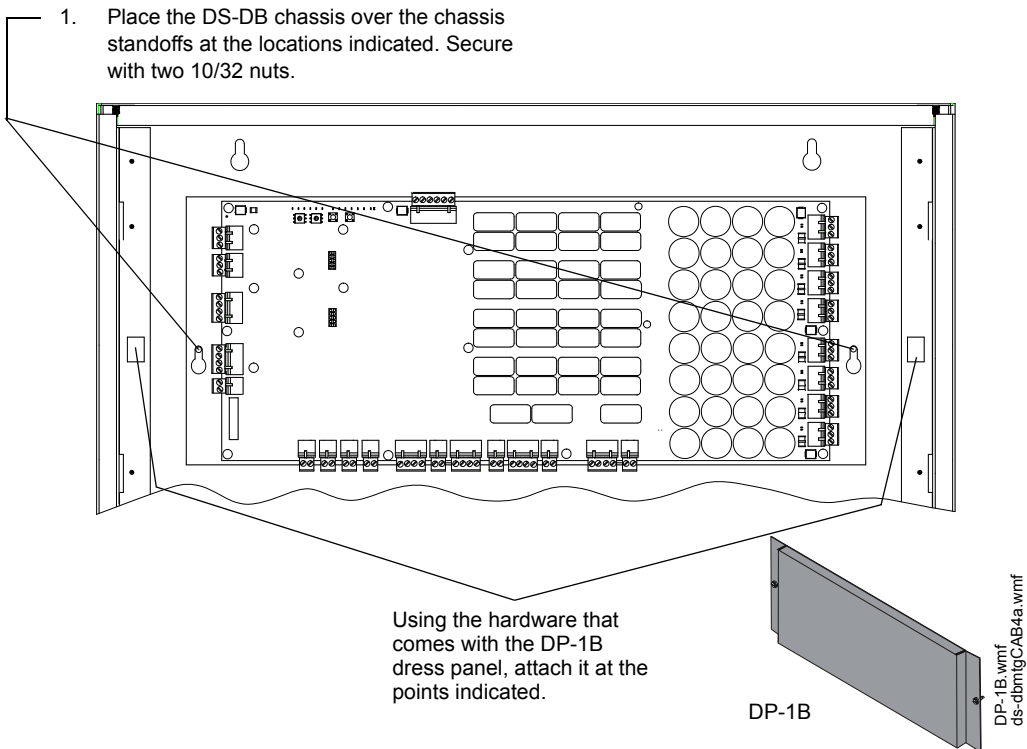

Figure 2.4 DS-DB Cabinet Installation



NOTE: Digital amplifiers can produce significant heat. Different cabinets can handle different amounts of heat. Refer to Heat Dissipation Document (53645) to determine dissipation figures for the equipment you are installing, and match it with an appropriate cabinet.

2.2.2 Wiring

Power to the DS-DB

The DS-DB may be powered using *either* the power harness connection at J9, *or* the 24V connection at TB24. When TB24 is not used to power the DS-DB, it may be used to power another device within the same cabinet.

■ Power Harness Connector - J9

The DS-DB may be powered by the AMPS-24 (AMPS-K2 version*) power supply using the supply’s power harness. Connect J9 on the DS-DB to TB1 MAIN 24V on the AMPS-24/E using Cable 75637. The power supply must be in the same cabinet as the DS-DB, or it must be in a cabinet within the 20-foot range of the cable, with the cable in conduit between the cabinets.

* *The AMPS-K2 can be identified by “AMPS-K2” silkscreened in the upper left corner of the rear board, or by the “CPS-24” label on the power supply heat shield.*

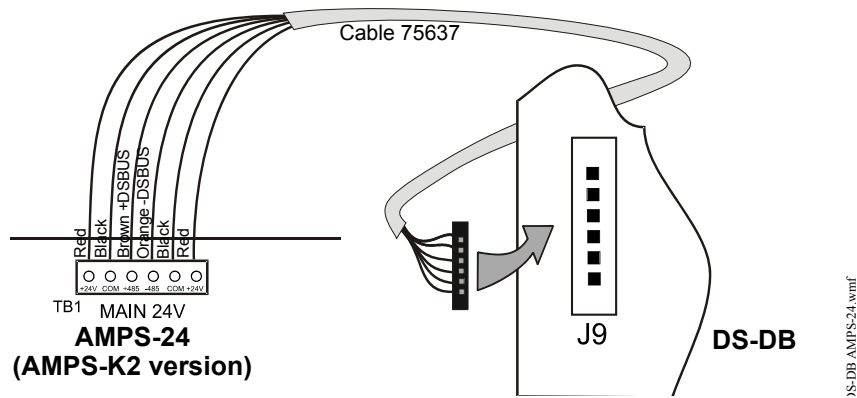

Figure 2.5 DC Power Connections

■ 24V Power to DS-DB - TB24

The DS-DB may be powered through TB24 by any power-limited (Class 2), regulated, UL/ULC Listed power supply for fire applications that is monitored by a panel or device other than the DS-DB, and capable of supplying the amount of power required by the DS-DB. For example, an AMPS-24* that is powering - and being monitored by - an NFS2-3030 using the power harness can indirectly power the DS-DB from the 24V accessory power connections on the panel board.

* *Any version AMPS-24 that fits the above monitoring and power criteria may be used.*

24V Auxiliary Power - TB24

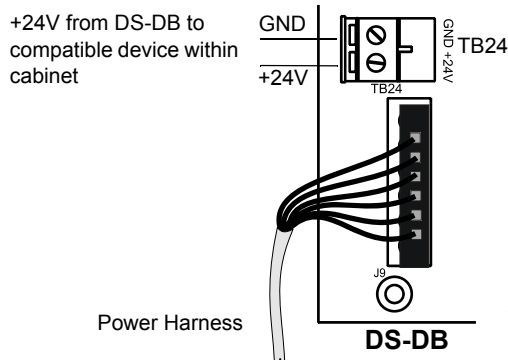

Figure 2.7 TB24 Auxiliary Power

+19-28V to DS-DB from power-limited (Class 2), regulated UL/ULC Listed power supply for fire applications.

- capable of supplying DS-DB power requirements.
- monitored by a panel or device other than the DS-DB.

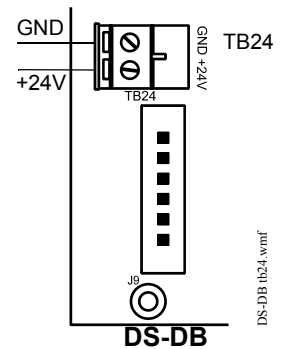

Figure 2.6 DS-DB Powered thru TB24

When the DS-DB is powered through its power harness connection (J9), TB 24 can provide 24V power to another device within the same cabinet.

It can also power the DS-DB as described in the section “24V Power to DS-DB - TB24” above.

Alarm Bus - TB26

The DS-DB general alarm connections are used to receive general

alarm messages from an FACP via an SLC device, or via the Notification Appliance Circuit of an FACP or power supply.

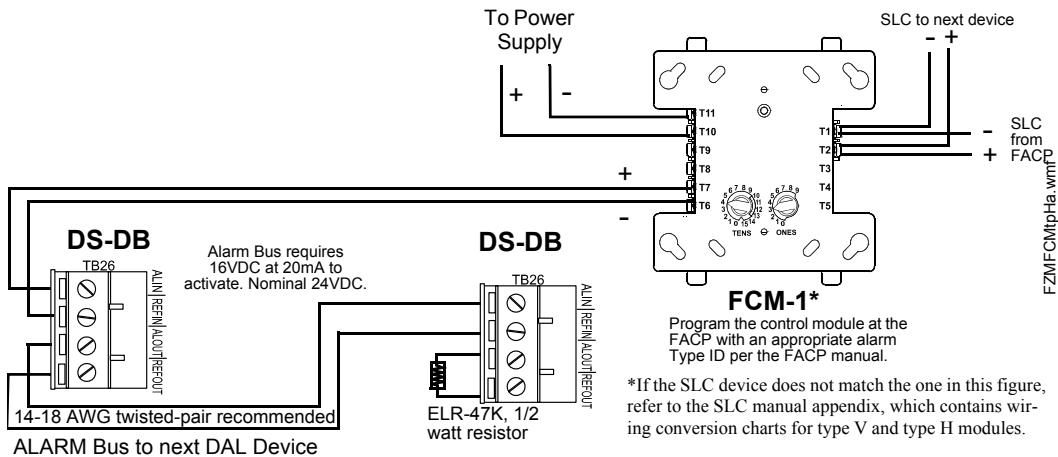

Figure 2.8 Alarm Bus Connections to FCM-1

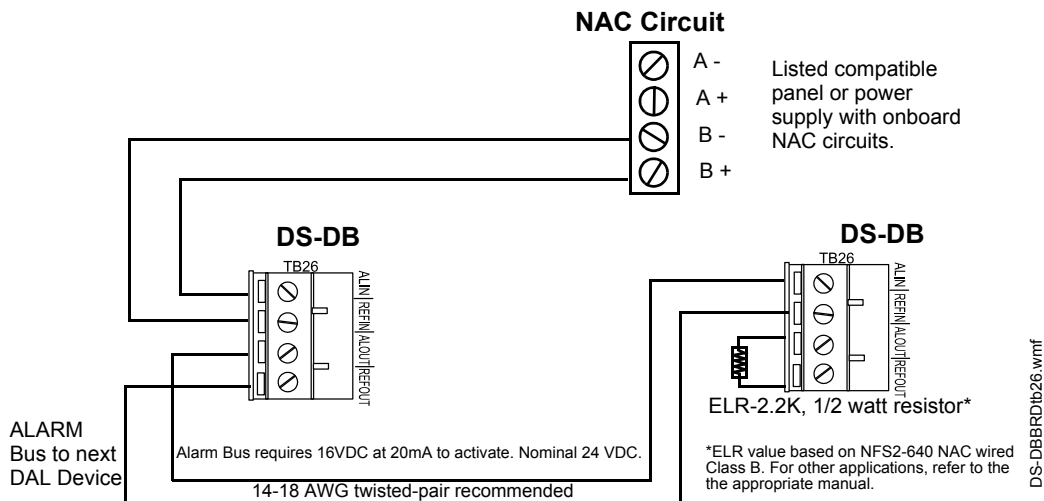

Figure 2.9 Alarm Bus Connections to NAC

Refer to the SLC manual and specific panel or power supply manual for more information

Digital Audio Ports A and B

Digital Audio Ports A and B (DAP A and DAP B) allow digital communication with the DVC over the Digital Audio Loop (DAL). Amplifier programming from the DVC; control, audio, trouble, address and firefighter’s telephone data; and live voice paging can be communicated through these ports. They may also act as repeaters, in that what is received at one port is transmitted out the other. Events generated at the DS-DB will be transmitted out both ports.

Each DS-DB board occupies two of the 32 DAL addresses.

■ **Wire Connections**

Refer to the Wiring Guide, p/n 52916ADD, for acceptable wire types and associated distances between ports.
Do not splice a cable. Splicing will degrade the signal, and the recommended distance will no longer apply.

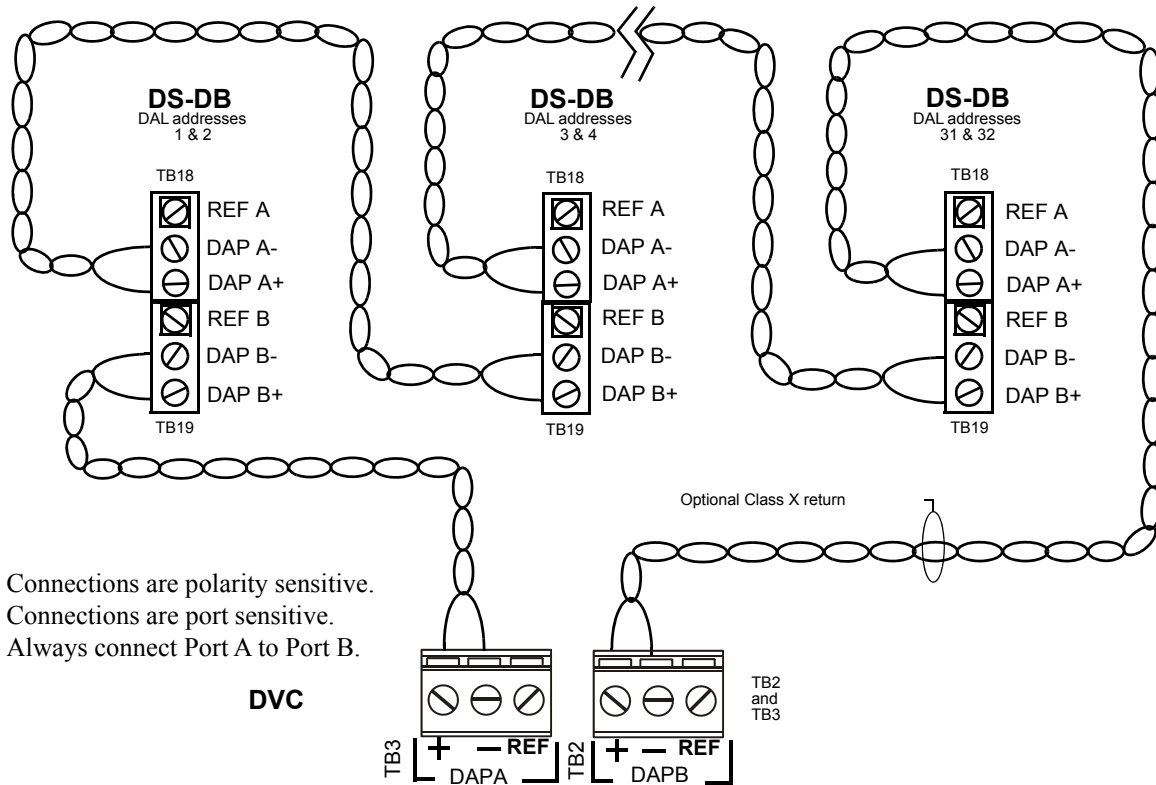

Figure 2.10 Wire the DS-DB Digital Audio Loop Connections



NOTE: Digital Audio Ports A and B must be wired in Class B or Class X configuration. Do not wire them in bus configuration.



NOTE: Class B configuration must be installed in accordance with the requirements for survivability from attack by fire in the National Fire Alarm Code, NFPA 72.

■ **Fiber and Wire/Fiber Connections**

DS-DB boards are wire, but may be converted partially or fully to fiber boards with the use of fiber option modules. (Refer to Section 5 on page 46 for more information on fiber option modules.)

Figure 2.11 illustrates an example of how a DAL can be formed using mixed wire and fiber connectors.



NOTE: If a fiber option module is installed on a digital audio port, that port may *not* also be used for a wire connection.

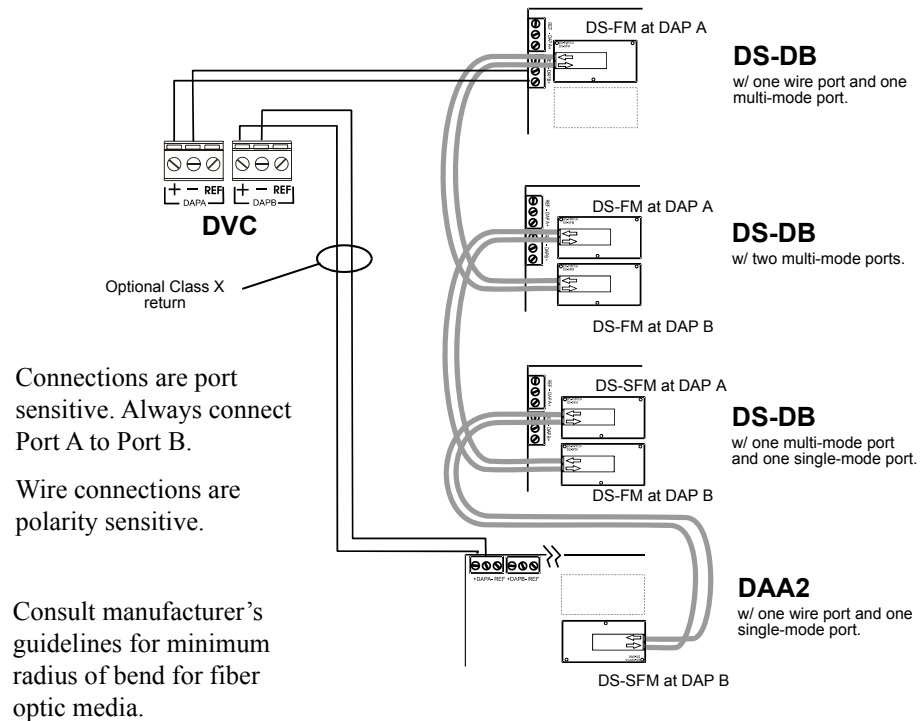

Figure 2.11 Fiber/Wire DAL Configurations



NOTE: Class B configuration must be installed in accordance with the requirements for survivability from attack by fire in the National Fire Alarm Code, NFPA 72.

FFT Riser Connections

The Firefighter Telephone Riser connections (TB25) provide for the use of firefighter's telephones (FFTs) on an analog network. They are a means of connecting various FFT telephone control modules and devices, such as FTM-1 modules, AFAWS, FPJ, or RPJ-1, to the DS-DB.

The FFT riser may be wired in NFPA Class A or Class B configuration. VeriFire Tools must be used to select "Installed, 4 Wire" for Class A, or "Installed, 2 Wire" for Class B, for trouble supervision. Class B configurations require a 3.9k ohm 1/2 watt end-of-line resistor (P/N R-3.9K).

There are two ways that firefighter telephones may be installed on a DS-DB FFT riser. Both configurations have a limit of seven active phones. (Refer to the FFT appendix in the DVC manual for more information on limits.)

Programming must reflect whether the riser contains modules or not. Use VeriFire Tools ("General 1" tab in the DVC database) to set these parameters.

1. "Install FTM" selected - FireFighter's Telephones must be wired to the output of the FTM modules. The telephone points will be SLC addresses.

2. “Install FTM” not selected - FireFighter’s Telephones must be wired directly to the DS-DB FFT riser. The telephone point will be a DS-DB phone point. (AxT; where x = the DS-DB address.)

14-18 AWG
twisted-pair
recommended

NOTE: If an FFT riser is not programmed for modules, telephone modules are not options.

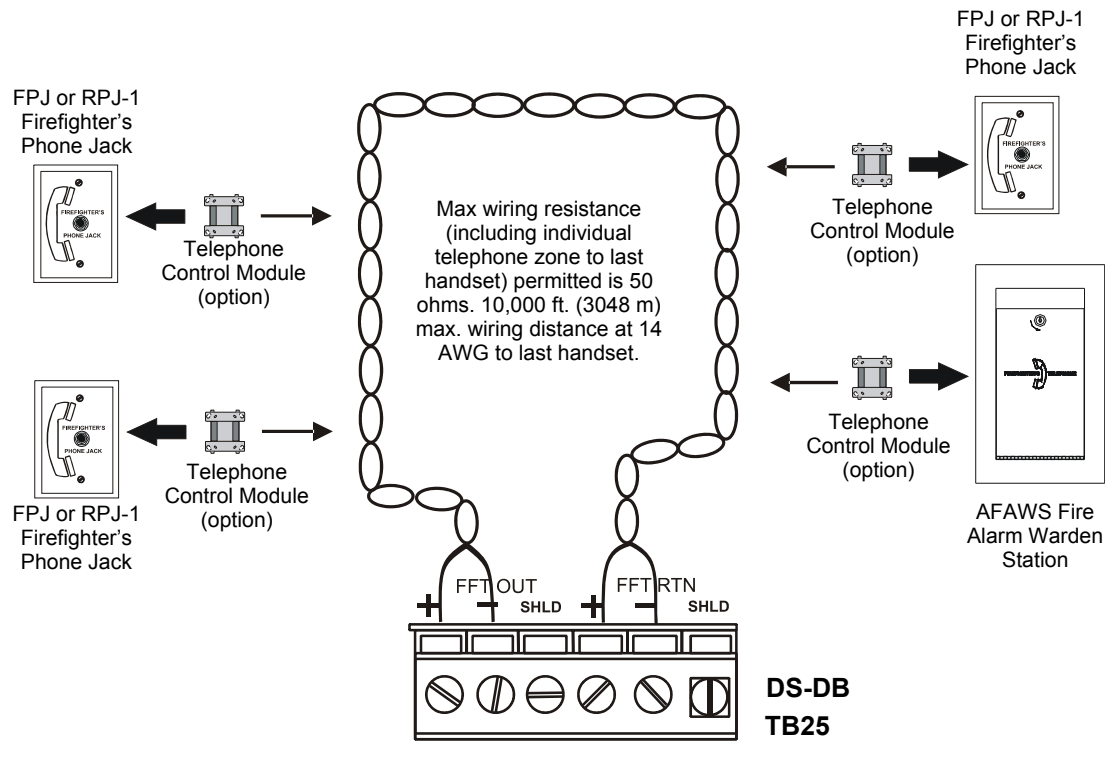

DAAPCCFFTriser.vmf

Figure 2.12 FFT Riser (Class A Example) with “Install FTM” Selected

An FHS firefighter’s handset may be used with the phone jacks in Figure 2.12. For a description of the DVC firefighter’s telephone network operation, refer to the FFT appendix in the DVC manual.

DS-BUS, TB17

The DS-BUS provides the means for basic (non-audio) EIA-485 communication between a DS-DB and its peripherals. It is terminated at its two farthest endpoints (determined by wiring distance) with a 120 ohm resistor, for a total of two per DS-BUS. These resistors are termination resistors, and are not for supervision. They should not be installed at every endpoint, only at the two farthest endpoints. The DS-DB has a termination switch, SW7, that should be set to “ON” to install the resistor. Refer to “DS-BUS - TB17” on page 10 for more information.

When the DS-DB is powered through its power harness connections (J9) by an AMPS-24 power supply (AMPS-K2 version - see “Power to the DS-DB” on page 17), the AMPS-24 is always one of the endpoints.

To avoid extraneous noise on the DS-BUS bus, all connected devices must share a common ground.



NOTE: This is accomplished automatically when the amplifiers are sharing batteries.

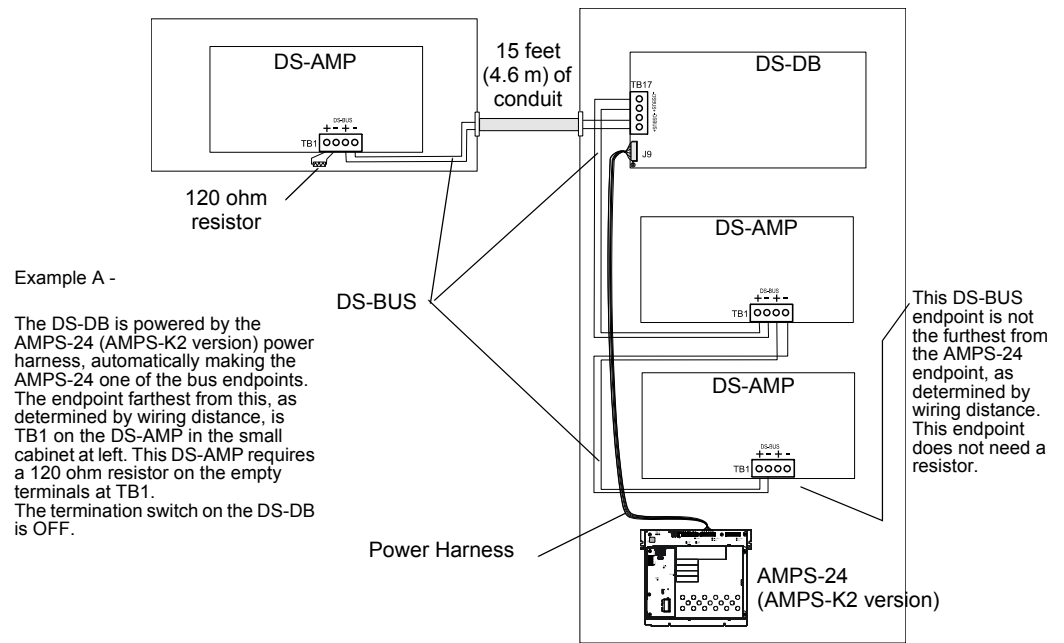

Figure 2.13 DS-BUS Configuration, Example A

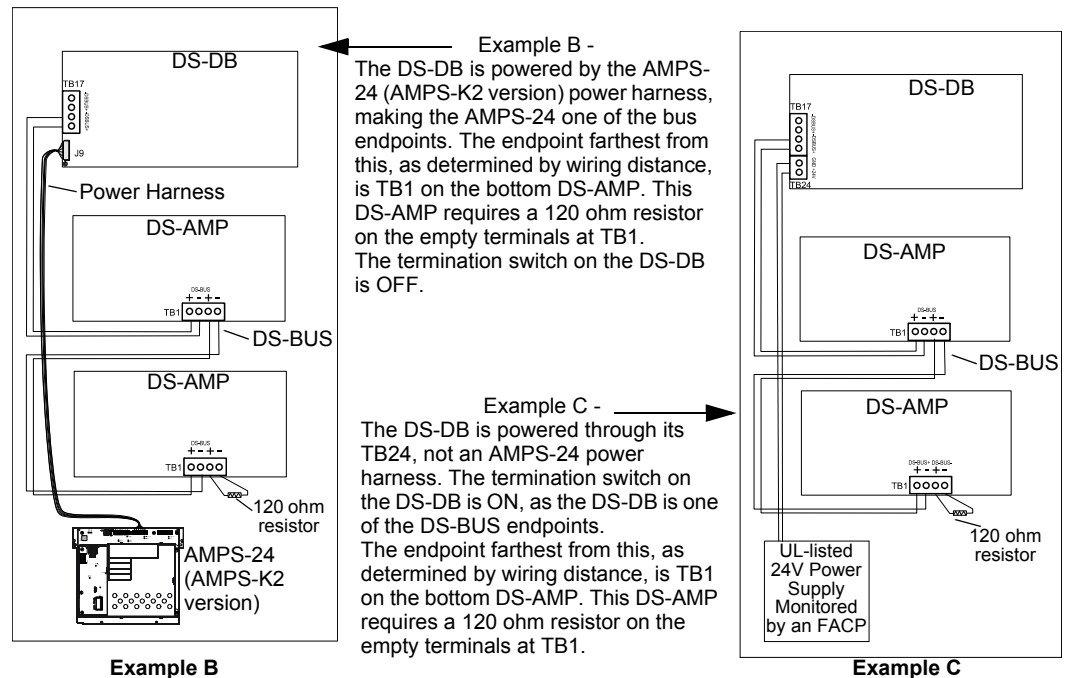

Figure 2.14 DS-BUS Configurations, Examples B and C

Refer to Section 2.3.3 on page 31 for setting the DS-DB termination switch.

Refer to the DVC Manual for DS-BUS addressing. Note that a DS-BDA takes on the DS-BUS address of the DS-AMP to which it is attached.

OUT 1 through 4, TB20 through TB23

TBs 20 through 23 provide four DVC-AO-level audio outputs for connection to amplifiers. One primary and one backup amplifier may be connected to each output, for a total of up to four primary and four backup amplifiers per DS-DB. Two amplifiers may be connected to a single OUT terminal by using the amplifier passthrough connections.

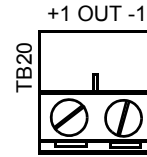

Figure 2.15 OUT Connections

The DS-DB and its amplifiers must be in the same cabinet, or within the same room with wiring in conduit.

Amplifiers are mapped to specific DS-DB outputs in VeriFire Tools. Refer to the DVC manual or the program help file for instructions.

Refer to Figures 2.17 and Figure 2.18 for illustrations of amplifier connections.

Primary and Backup 1 through 4, TB9 through TB16

The primary and backup connections accept amplified high-level input from DS-AMPs and DS-BDAs. Each of the DS-DB's primary and backup amplifiers must be connected to a primary or backup terminal.

Voltage for each primary and backup pair is set using the AMP1 through AMP4 slider switches on the DS-DB. (Refer to "AMP1 - AMP4 Voltage Selection Switches, SW3 - SW6" on page 31.)

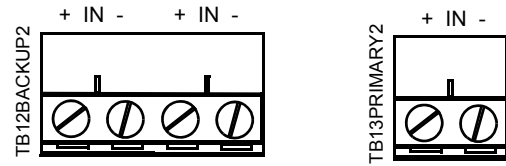

Figure 2.16 Primary and Backup Connections

Amplifiers are mapped to specific DS-DB inputs in VeriFire Tools. Refer to the DVC manual or the program help file for instructions.

Refer to Figures 2.17 and Figure 2.18 for illustrations of primary and backup input connections.

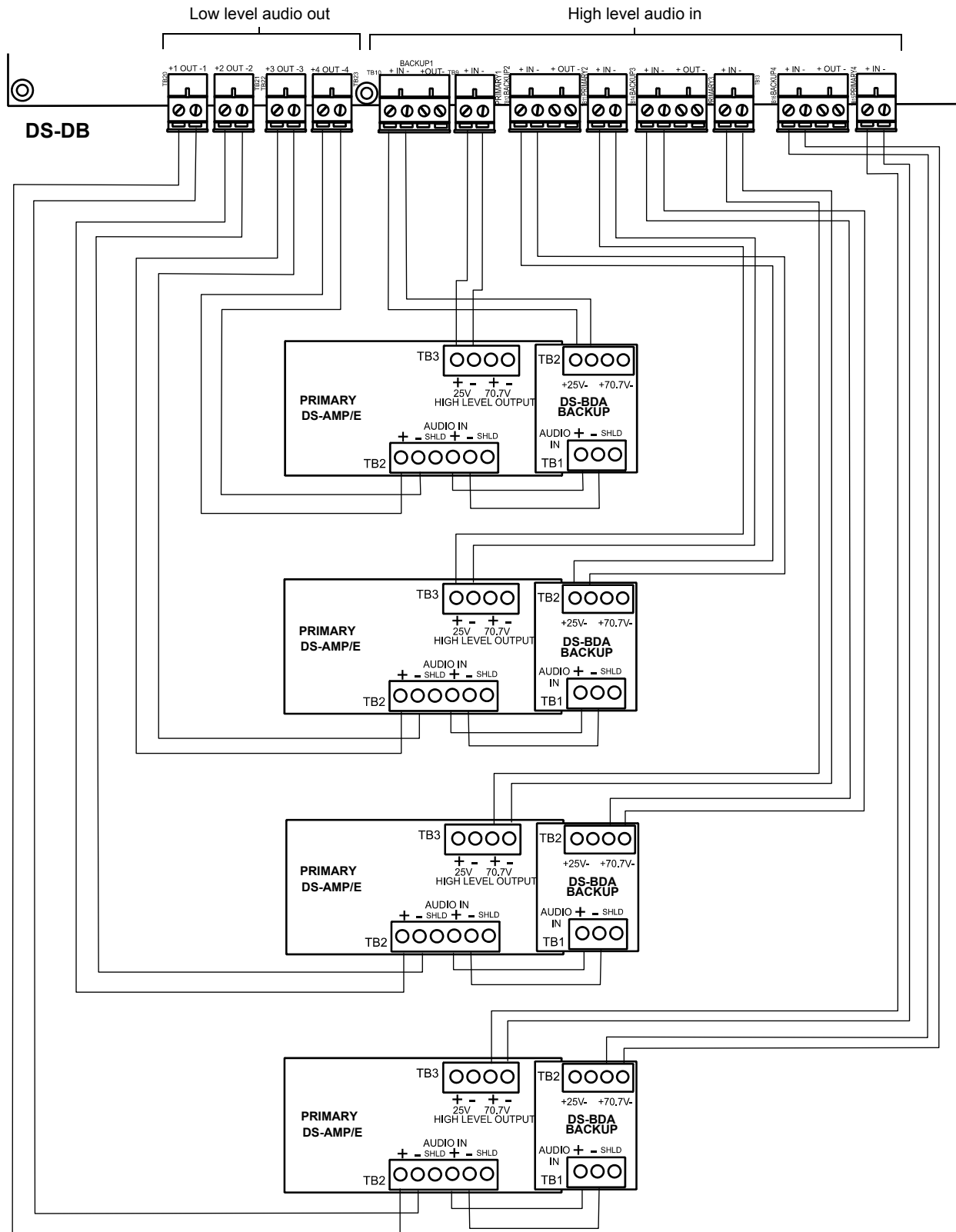

Figure 2.17 One-to-One Backup

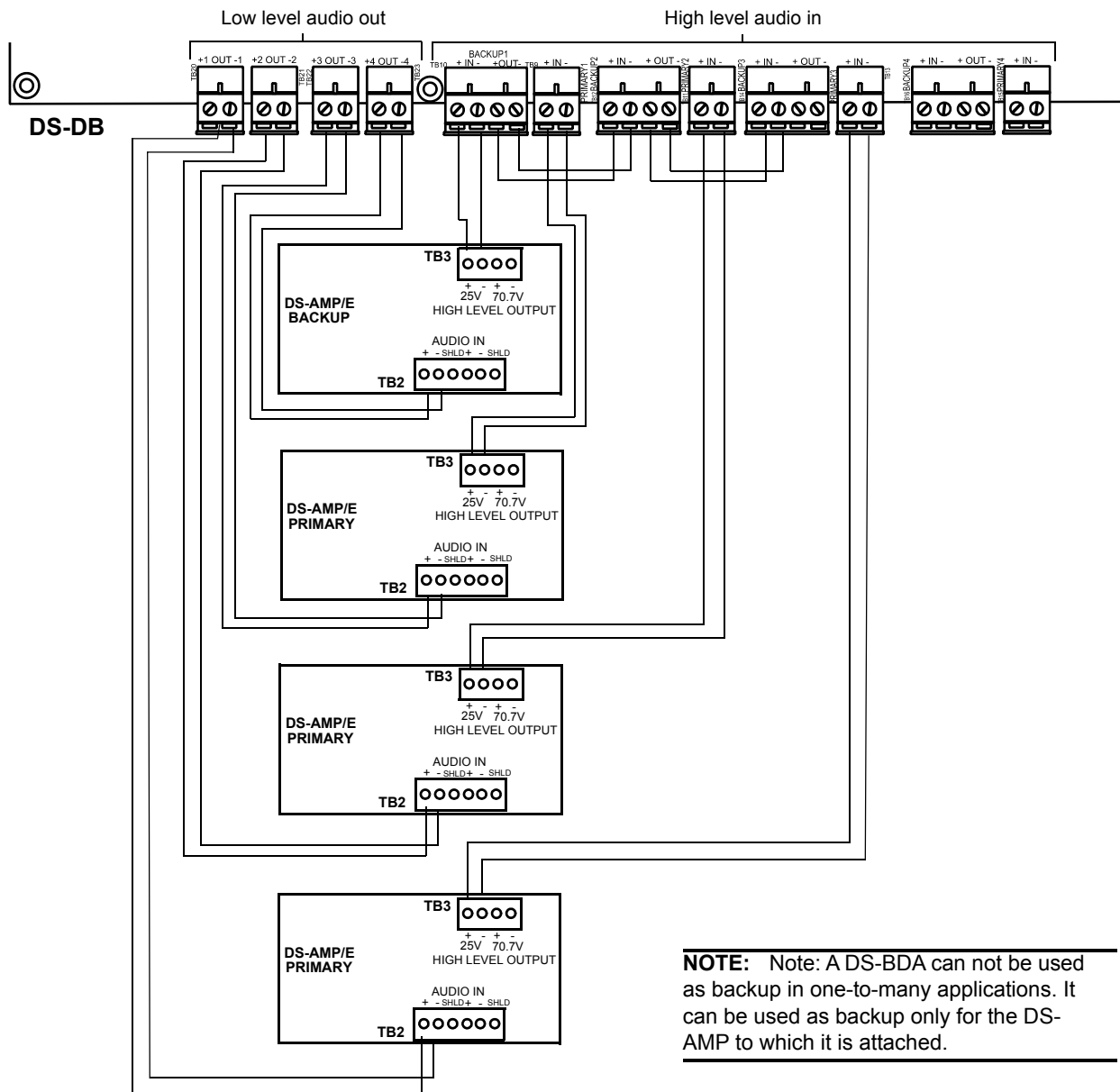
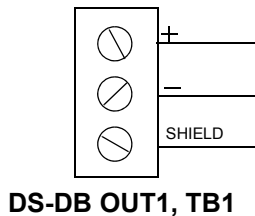

Figure 2.18 One-to-Many Backup, Example of One-to-Three Backup

Speaker Circuits - Audio Out, TB1 through TB8

Speaker circuits 1 through 8 (TB1 through TB8) provide for up to four NFPA Class A connections for high-level audio output, and up to eight NFPA Class B connections.



High level audio Out

- Ckt 1 (TB1)
- Ckt 2 (TB2) - TB2 may act as a 4-wire return for TB1
- Ckt 3 (TB3)
- Ckt 4 (TB4) - TB4 may act as a 4-wire return for TB3
- Ckt 5 (TB5)
- Ckt 6 (TB6) - TB6 may act as a 4-wire return for TB5
- Ckt 7 (TB7)
- Ckt 8 (TB8) - TB8 may act as a 4-wire return for TB7

Figure 2.19 Speaker Circuit Connections

The DS-DB Riser Mode setting in VeriFire Tools is global. That is, whatever Riser Mode setting is selected in programming applies to all the speaker circuits on the DS-DB. Selecting a Riser Mode setting other than NORMAL (NAC) limits each DS-DB group to one speaker circuit.

■ In Normal (NAC) Mode

When a DS-DB's Riser Mode is programmed NORMAL (NAC) (refer to the DVC Digital Voice Command manual for programming description), the amplified signal from the DS-DB may be connected directly to speakers.

Following are some examples of Class A and Class B configurations. Other configurations are possible. Output circuits programmed as NORMAL (NAC) mode are power-limited (Class 2).

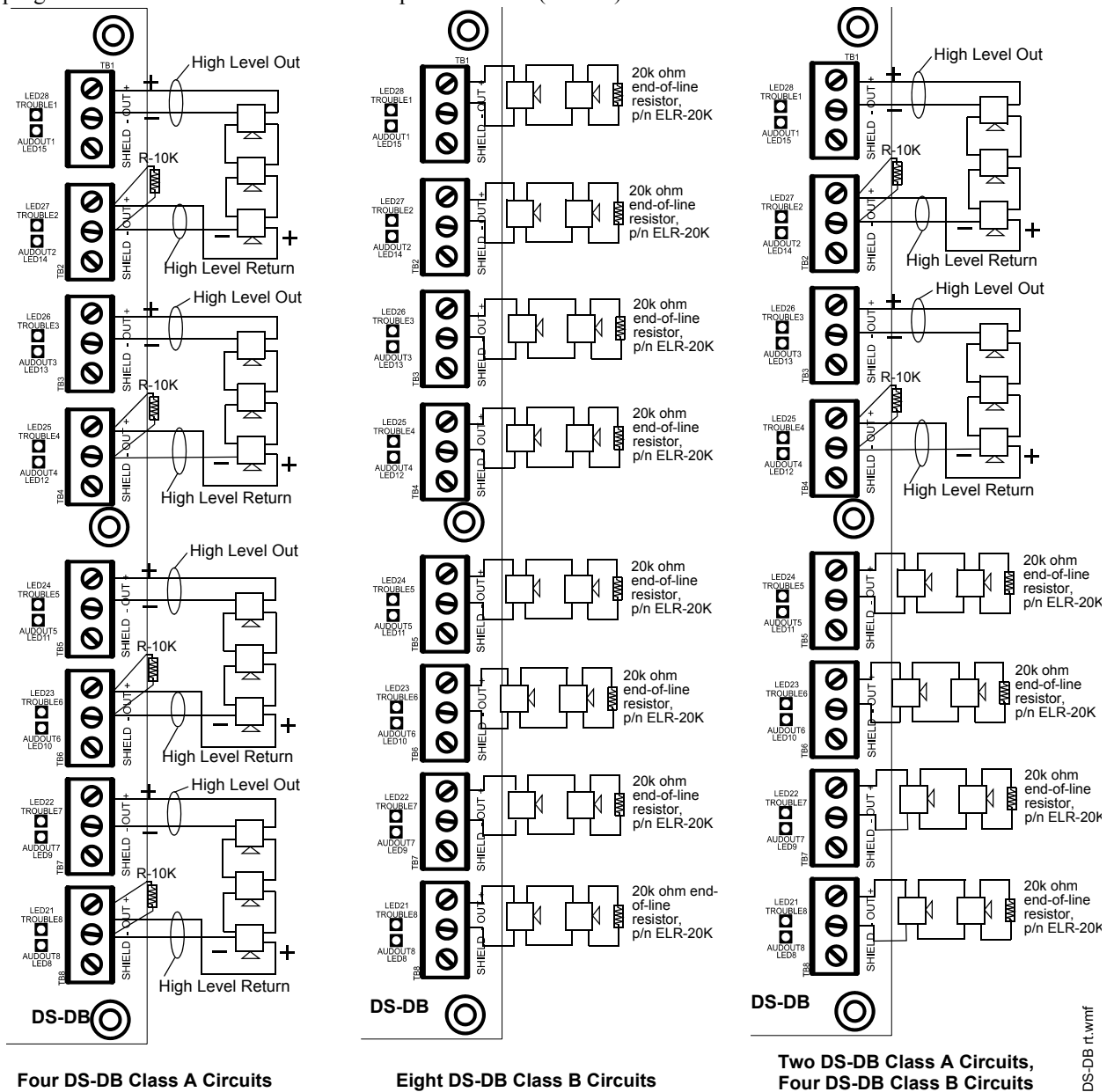

Figure 2.20 Some Examples of Normal Riser Mode Class Configurations

■ In Riser Mode to Control Modules

When a DS-DB's Riser Mode is programmed **RISER MODE TO CONTROL MODULES** (refer to the DVC Digital Voice Command manual for programming), the amplified signal from the DS-DB may be routed to multiple speaker circuits using SLC control modules.

Do not use background music in this mode. The DS-DB will provide speaker circuit supervision only when idle. Output circuits programmed as **RISER MODE TO CONTROL MODULES** are non-power-limited.

Only one speaker circuit is available per group when this riser mode type is selected.

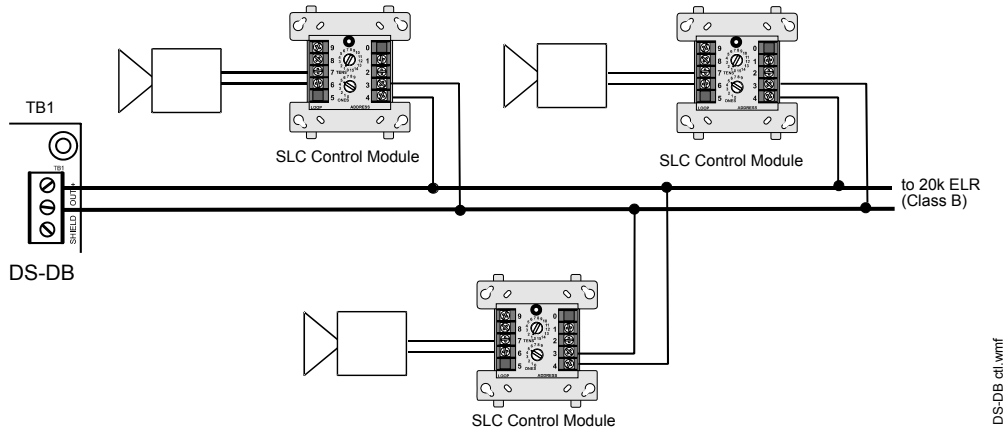

Figure 2.21 DS-DB Riser Mode to Control Modules

■ In Riser Mode to RSM-AIM Series Canadian Room Isolator Module

When a DS-DB's Riser Mode is programmed **RISER MODE TO RSM/AIM SERIES MODULES** (refer to the DVC Digital Voice Control manual for programming), the amplified signal from the DS-DB is routed to RSM-1A or AIM-1A room isolator modules. Output circuits programmed as **RISER MODE TO RSM/AIM SERIES MODULES** are non-power-limited.

Only one speaker circuit is available per group when this riser mode type is selected.

AIM-1A - Provides isolation to a separate circuit on an audio riser. A short circuit on an AIM-1A speaker circuit will not disable other speaker circuits on the riser.

RSM-1A - Works same as the AIM-1A, with the exception that there is a silence button for in-suite operation. The silence button will silence the audible signal to the module's circuit for ten minutes during alarm. Resounding will occur automatically after ten minutes. To override the ten minute silence, CBE programming must be done at the FACP so that it interrupts the module's 24VDC power for two seconds.

NFS2-3030 example:

Give the isolator module's 24VDC source a common ground with the DS-DB amplifier. Control it with a relay module that has Special Function Zone 14 in its CBE list. Special Function Zone 14 will activate for ten seconds when a reset is initiated at the panel. Use this period to disable the 24VDC for those 10 seconds to clear a local silence.

Remove jumpers for speaker applications. (Refer to Figure 2.22.)

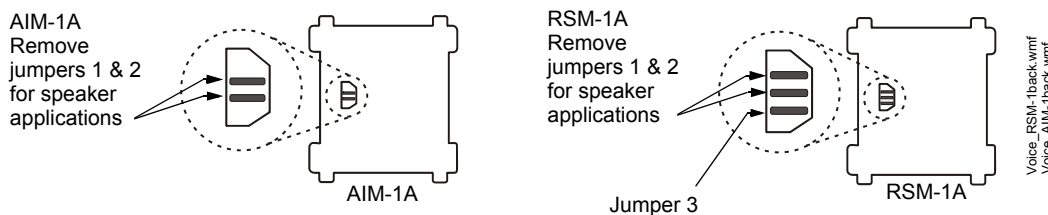

Figure 2.22 Jumper Settings for Speaker Applications

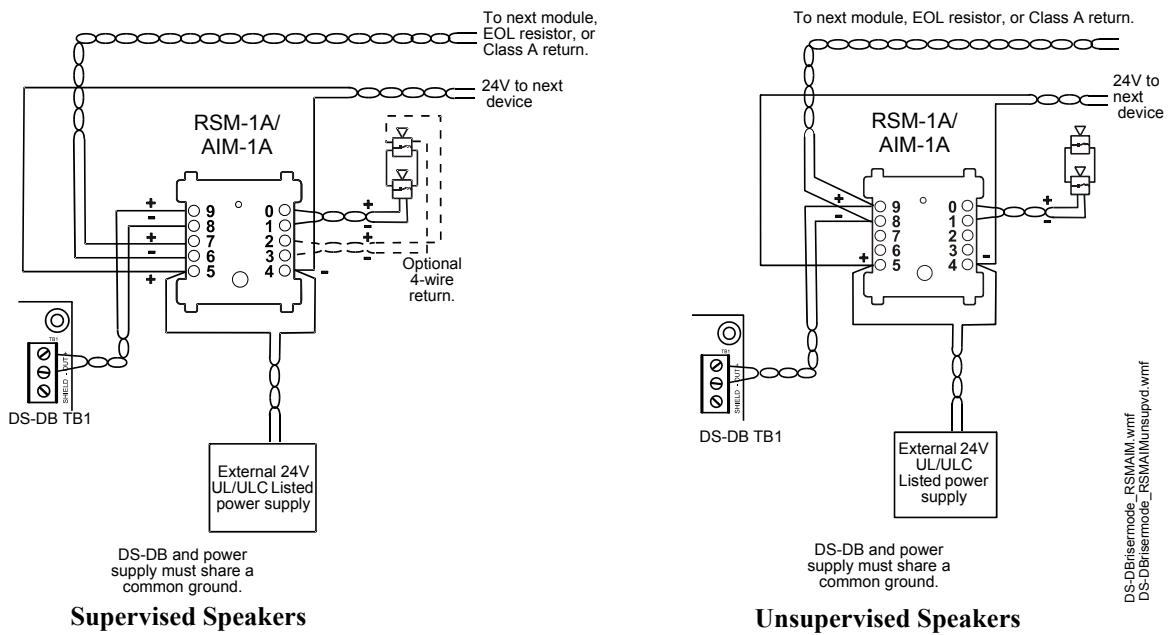

Figure 2.23 DS-DB Riser Mode to RSM-1/AIM-1 Modules



NOTE: AA Series Amplifiers may not be used when this mode is selected.

In Riser Mode to CIM/CSM Series Canadian Room Isolator Modules

When a DS-DB's Riser Mode is programmed **RISER MODE TO CIM/CSM SERIES MODULES** (Refer to the DVC manual for programming), the amplified signal from the DS-DB is routed to a CIM-2A module, which feeds the signal to one or two CSM-1A modules. Output circuits programmed as **RISER MODE TO CIM/CSM SERIES MODULES** are non-power-limited. Only one speaker circuit is available per group when this riser mode type is selected.

A pre-announce tone of 800 Hz will clear a local silence.

Do not use background music in this mode. The DS-DB will provide speaker circuit supervision only when idle.

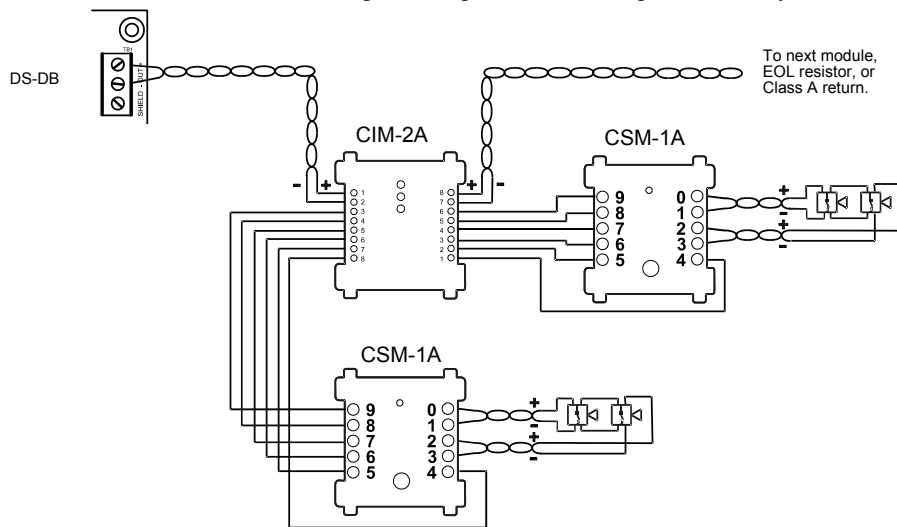

Figure 2.24 DS-DB Riser Mode to CIM-2A/CSM-1A Modules



NOTE: AA Series Amplifiers may not be used when this mode is selected.

Wiring Fault Testing

Test wire-to-wire faults with 0 (zero) ohm impedance.

UL Power-limited (Class 2) Wiring Requirements

Power-limited (Class 2) and non-power-limited circuit wiring must remain separated in the cabinet. All power-limited circuit wiring must remain at least 0.25 inches (6.35 mm) from any non-power-limited circuit wiring. All power-limited and non-power-limited circuit wiring must enter and exit the cabinet through different knockouts and/or conduits.

In Figure 2.25 below, the cabinet sides are given an exploded view to more easily see the wiring.

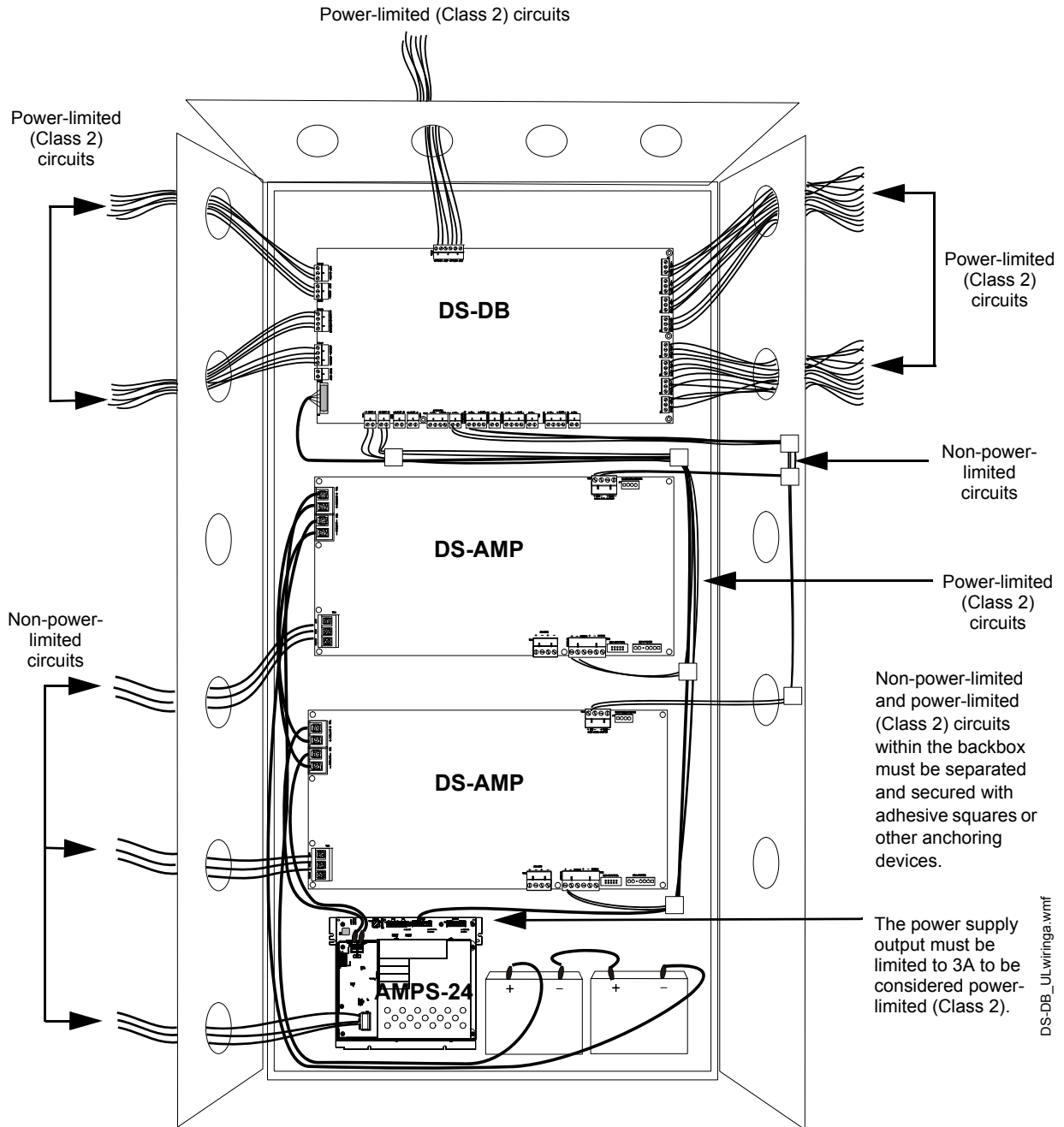

Figure 2.25 Typical Backbox Wiring

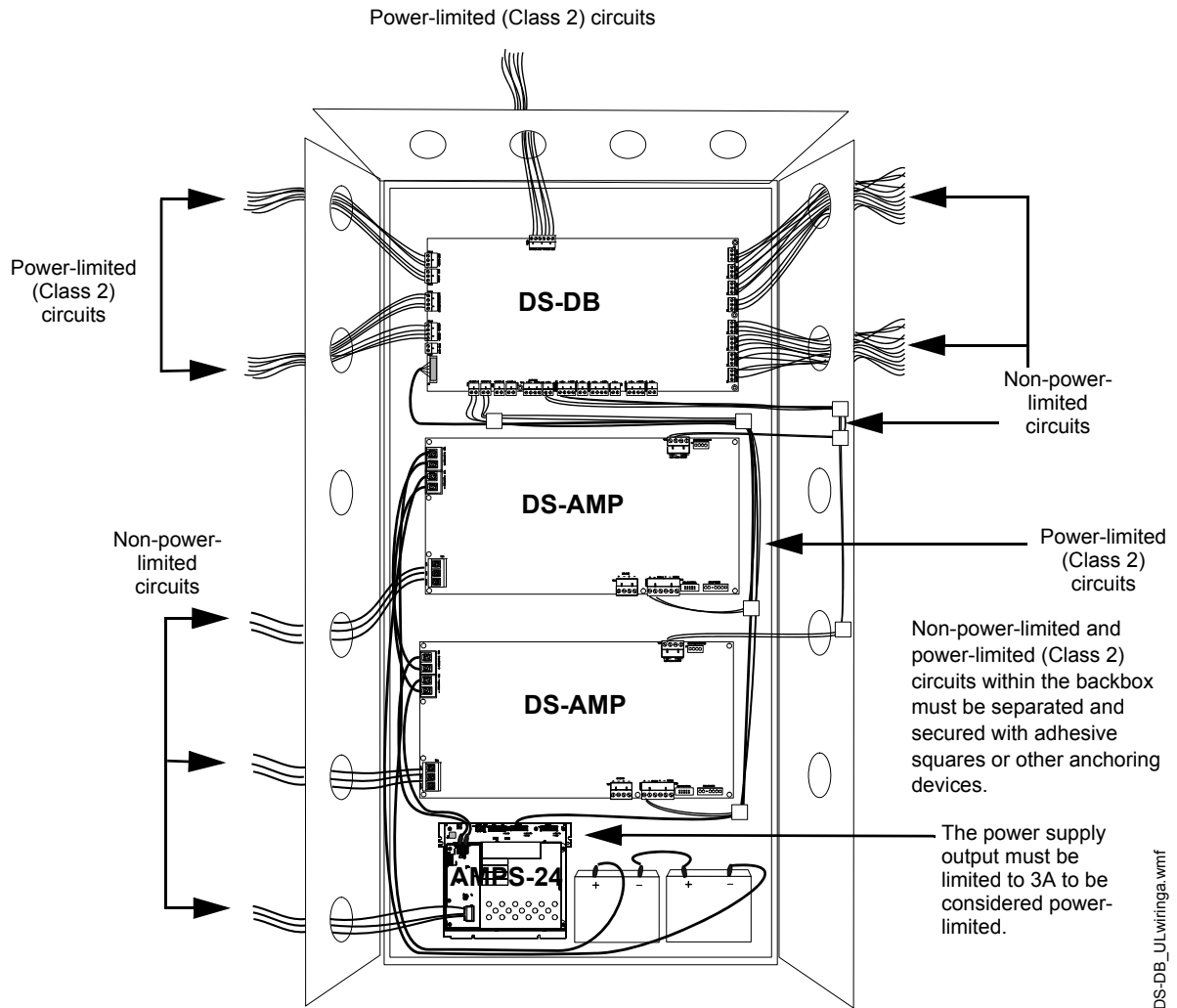

Figure 2.26 Backbox Wiring with Outputs Programmed for Non-power-limited Riser Modes

2.3 Configuration

2.3.1 Address Switches, SW1, SW2

A DS-DB occupies two of the 32 digital audio loop addresses.

Address switches SW1 (tens) and SW2 (ones) are used to set the DS-DB's first address on the DAL. The second address is generated automatically as the next address.

Refer to Figure 2.27 for an illustration of address settings and to Figure 2.2 on page 12 for the location of the switches.

Addresses one (1) through 31 may be used as DS-DB address switch settings. Address 00 and addresses above 31 will generate a DS-DB trouble.

The default address setting for the DS-DB as it arrives from the factory is 00.



Figure 2.27 DS-DB Address Switches

DA.A.Addressswitchs.wmf

2.3.2 AMP1 - AMP4 Voltage Selection Switches, SW3 - SW6

Set each switch to the output voltage of the amplifier being used prior to initial power-up.



CAUTION:

DO NOT MIX VOLTAGES WITHIN A GROUP. REFER TO THE "AUDIO" SECTION OF THE DVC DIGITAL VOICE CONTROL MANUAL FOR MORE INFORMATION.

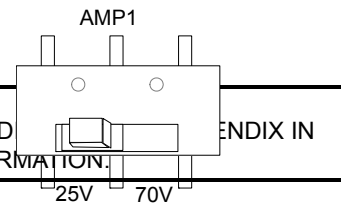

Figure 2.28 Voltage Selection Switch

newslderswitch.wmf

2.3.3 Termination Switch, SW7

The termination switch terminates the EIA-485 DS-BUS when set to ON. Refer to "DS-BUS, TB17" on page 21 for when to set this switch to ON.

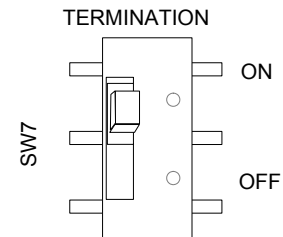

Figure 2.29 Termination Switch

SWgen.wmf

2.3.4 LOCSIL Local Silence Switch, SW9

This pushbutton control silences speaker outputs on circuits 1 through 4. This switch is enabled by the DS-DB when there is a communication loss with the DVC.

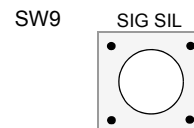

Figure 2.30 LOCSIL Switch

2.3.5 Test Switch, SW10

The test switch is used to clear a “trip” condition. When a DS-AMP is drawing more current from the power supply than expected and has been automatically disabled, it generates a “PRIMARY AMP \underline{x} TRIP or BACKUP AMP \underline{x} TRIP system trouble. When the condition causing the error is fixed, pressing this switch will return the amplifier to normal operation.

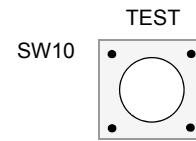

Figure 2.31 Test Switch

2.3.6 2Wire/4Wire Switch, SW12

The FFT riser may be wired in a Class A four-wire or a Class B two-wire configuration. Set the switch accordingly.

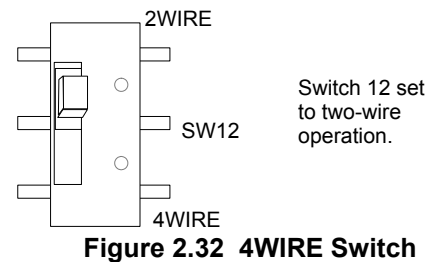

Figure 2.32 4WIRE Switch

DAA SW 1 and a4.wmf

2.4 Operation

2.4.1 Volume Control

The volume of audio messages is user-programmable through FACP/network annunciator Alter Status programming and VeriFire Tools Read Status Service Form.

2.4.2 FFT Communication

Refer to the “FFT” Appendix in the DVC Digital Voice Control manual for information on firefighter telephone communication.

2.4.3 Trouble Messages

DS-DBs will send trouble messages to the DVC through the wire or fiber DAL (Digital Audio Loop). The DVC in turn sends them to the panel or network annunciator. Refer to the “System Troubles” Appendix in the DVC manual for a list and description of system troubles.

2.4.4 Read/Alter Status

An NCA-2, NFS2-3030 and network workstation, as well as a computer running VeriFire Tools, will be able to read the status of a DS-DB and its speaker circuits. Refer to the appropriate panel manual or the VeriFire Tools Read Status Service Form.

A DS-DB speaker circuit may be disabled through NCA-2 and NFS2-3030 Alter Status panel programming and ACS programming.

Section 3: DS-AMP Digital Series Amplifiers

3.1 Description

The DS-AMP Digital Series Amplifiers are part of the DS-DB system, providing bulk amplification to the Digital Voice Command (DVC) system. Up to four DS-AMP amplifiers can be connected to one DS-DB, supplying high-level risers spread throughout an installation.

DS-AMP Primary and Backup Digital Audio Amplifiers			
DS-AMP	120VAC (50/60Hz)	125W	25 V _{RMS}
		100W	70 V _{RMS} *
DS-AMPE	220-240VAC (50/60Hz)	125W	25 V _{RMS}
		100W	70 V _{RMS} *
*70 V _{RMS} option requires step-up transformer, p/n DS-XF70V, ordered separately.			

Table 3.1 Digital Series Models

3.2 Features

- 125 watts of audio power at 25V_{RMS}, 100 watts of audio power at 70V_{RMS}
- DS-BUS communication with DS-DB.
- Compatible with DS-BDA that is being used as a backup or second audio channel*.
* There are group limitations on the second channel. Refer to the “Audio Groups” appendix in the DVC manual.

3.3 Specifications

AC POWER - TB4

120 VAC 50/60 Hz input

- 4.1 A maximum when used for 25V (125W)
- 3.55 A maximum when used for 70V (100W)

220-240 VAC 50/60 Hz input

- 2.4 A maximum when used for 25V (125W)
- 2.1 A maximum when used for 70V (100W)

Recommended 12-14 AWG (1.6 mm O.D.) with 600 VAC insulation.

BATTERY - TB5, TB6

Supplied cable connections to batteries for EQ-CAB and CAB-4. For battery sharing, use 12 AWG either in the same cabinet or in conduit for no more than 20 ft. (6.1 m).

HIGH LEVEL OUTPUT - TB3

Non-power-limited (Class 2).

Supervision provided by DS-DB.

Recommended wiring: 14-18 AWG, twisted-pair, unshielded.

AUDIO IN - TB2

Power-limited (Class 2) by source.

Supervision provided by DS-DB.

Recommended wiring: 14-18 AWG, twisted-pair, unshielded.

DS-BUS

EIA-485 connection.

Power-limited (Class 2).

120 ohm resistor required on empty TB1 terminals when this board is used as a DS-BUS endpoint. (DS-BUS and endpoints are described in “DS-BUS - TB17” on page 10.)

Use 14-18 AWG, twisted unshielded wire.

3.4 Layout

3.4.1 Connectors

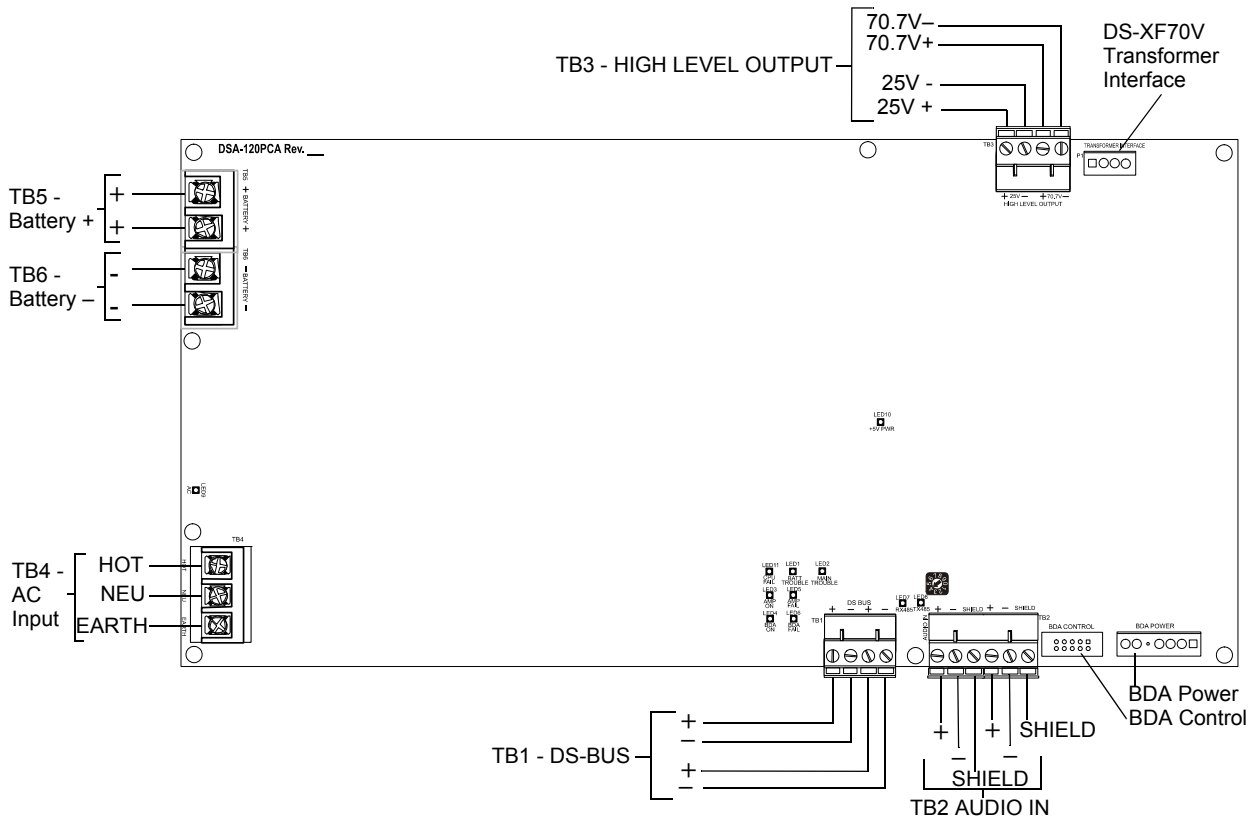

Figure 3.1 DS-AMP/E Connections

3.4.2 Indicators

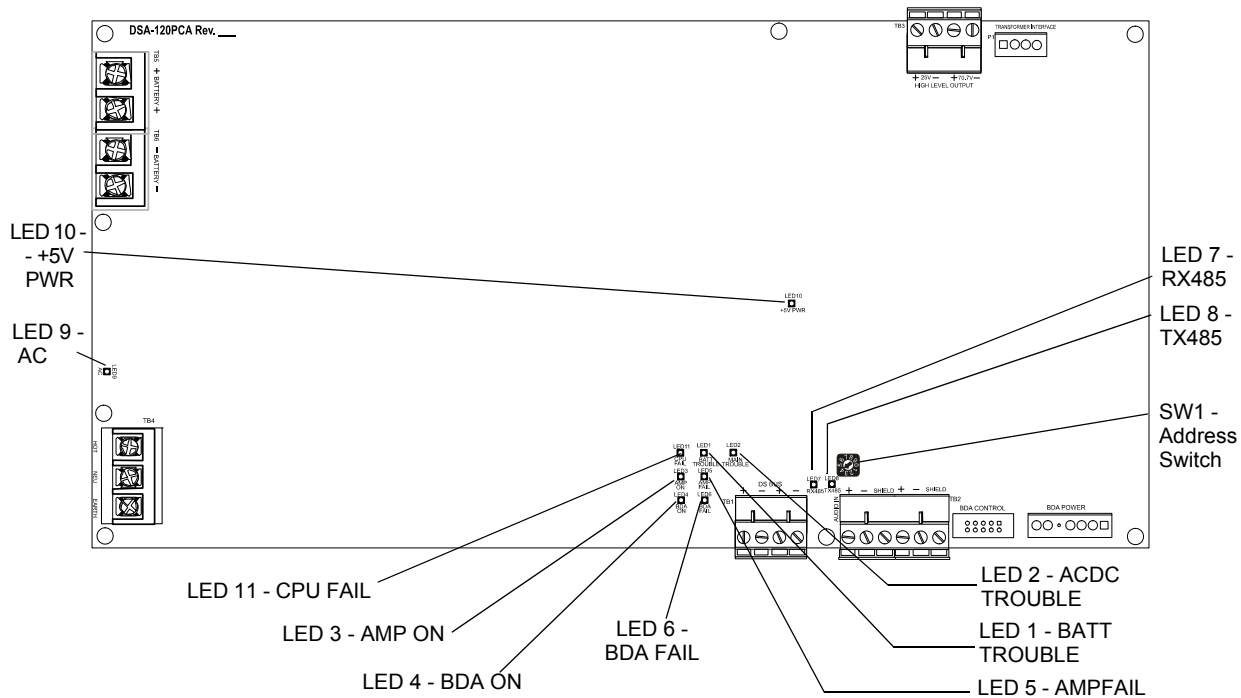

Figure 3.2 LED Indicator and Switch Positions

DS-AMP LEDs			
LED #	LED Name	Color	Description
1	BATT TROUBLE	Yellow	Illuminates for a high or low battery trouble condition.
2	ACDC TROUBLE	Yellow	Illuminates when 24V from AC/DC converter is out of tolerance.
3	AMP ON	Green	Illuminates when the internal audio amplifier is on.
4	BDA ON	Green	Illuminates when the BDA amplifier is on.
5	AMPFAIL	Yellow	Illuminates when the internal amplifier is not operating correctly.
6	BDA FAIL	Yellow	Illuminates when the BDA is not operating correctly.
7	RX485	Green	Illuminates when receiving data from the DS-BUS.
8	TX485	Green	Illuminates when transmitting data to the DS-BUS.
9	AC	Green	Illuminates while AC power is present.
10	+5V PWR	Green	Illuminates while +5V is present, indicating the board is powered.
11	CPU FAIL	Yellow	Illuminates when the DS-AMP's CPU has failed.
DS-AMP Switch			
SW #	Switch Name	Description	
SW1	Address	Rotary Address Selection Switch (1-4 only)	

Table 3.2 DS-AMP LED Indicator and Switch Descriptions

3.5 Installation

3.5.1 Cabinets

The DS-AMP arrives from the factory already installed on its chassis. A DS-BDA can be mounted on it, as well as two transformers required for 70V operation. (Refer to Figure 3.4). The DS-AMP chassis mounts in a CAB-4 Series cabinet, as well as in an EQ Series backbox.

Prior to installation,

- Review the installation precautions at the front of this manual.
- Installers should be familiar with the standards and codes specified in “Standards and Other Documents” on page 7.
- Ensure all wiring will comply with national and local codes.
- Review the installation instructions in this section.

**WARNING:**

Wear a static discharge wrist strap to prevent equipment damage.

Locate the cabinet backbox on a surface that is in a clean, dry, vibration-free area. The top should be located so that all operational buttons, switches, displays, etc. are easily accessible and/or viewable to the operator - usually no more than 66 inches (1.7 m) above the floor. Allow sufficient clearance around the cabinet for the door to swing freely, and for easy installation and maintenance of equipment.

Follow the instructions below.

1. Mark and pre-drill two holes for the keyhole mounting bolts. Install bolts.
2. Select and punch open the appropriate cabinet knock-outs. (For selection guidelines, see “UL Power-limited (Class 2) Wiring Requirements” on page 29.)
3. Using the keyholes, mount the backbox on the two bolts.
4. Mark the location of the two lower holes, remove backbox and drill the mounting holes.
5. Mount the backbox over the top two screws, then install the remaining fasteners. Tighten all fasteners securely.
6. Feed wires through appropriate knockouts.
7. Install DS-AMP according to the following instructions before installing the door per the Cabinet Installation Document.

The DS-AMP fills one row of any EQ or CAB-4 series cabinet.

EQ Series Cabinets and Doors

The EQ Series cabinets come in B, C, and D sizes. The row spacing allows DS-AMP amplifiers to be mounted in any row, and the doors are equipped with ventilated panels for heat dissipation. The cabinets were designed so that all DS-AMP boards can be used in any or all cabinet rows. Batteries may be accommodated in separate cabinets or battery backboxes, or in the bottom row of an EQCAB if there is room.

The following models are available:

- EQCAB-D4 - Four rows. Accommodates up to four DS-AMPs. Consists of P/Ns EQBB-D4 (black backbox) and EQDR-D4 (black door with ventilated panels).
- EQCAB-C4 - Three rows. Accommodates up to three DS-AMPs. Consists of P/Ns EQBB-C4 (black backbox) and EQDR-C4 (black door with ventilated panels).
- EQCAB-B4 - Two rows. Accommodates up to two DS-AMPs. Consists of P/Ns EQBB-B4 (black backbox) and EQDR-B4 (black door with ventilated panels).

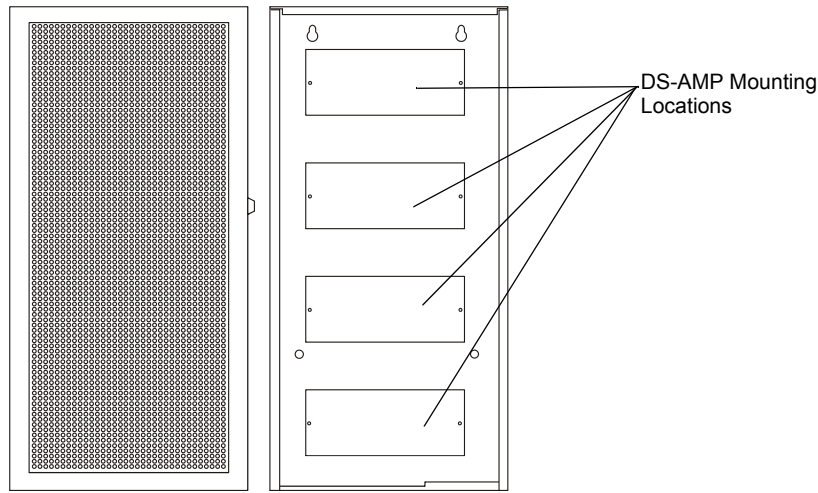

Figure 3.3 EQBB-D4 Backbox and EQDR-D4 Door



NOTE: Digital amplifiers can produce significant heat during their duty cycles. Different cabinets can handle different amounts of heat. Refer to the Heat Dissipation Calculation Document (53645) to determine dissipation figures for the equipment you are installing, and match it with an appropriate cabinet.

Figure 3.4 illustrates a typical DS-AMP installation. A DP-1B dress panel, ordered separately, can be used to cover the row.

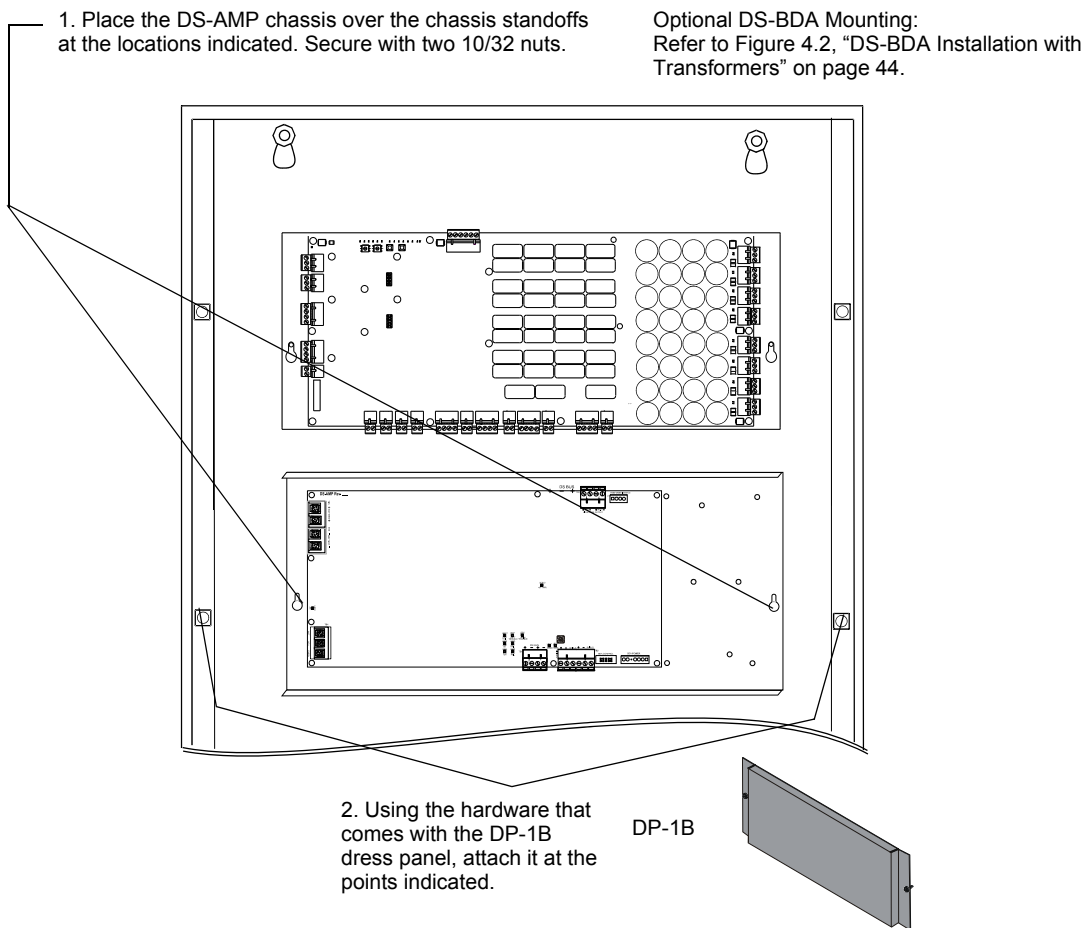

Figure 3.4 DS-AMP Cabinet Installation

3.5.2 Batteries, Installation



WARNING: Batteries contain sulfuric acid which can cause severe burns to the skin and eyes, and can destroy fabrics. If contact is made with sulfuric acid, immediately flush skin or eyes with water for 15 minutes and seek immediate medical attention.

The DS-AMP must share batteries with a UL 864 listed charging power supply rated for the battery requirements of the specific application. The charging power supply must provide ground fault detection. See Appendix A, “DS-DB and DS-AMP Battery Calculations” for current draw calculations to determine the battery size required for this installation.

Batteries for the DS-AMP may be installed in any of the following configurations:

- In the bottom of a CAB-4 series cabinet that holds the DS-AMP. They can also be installed in the bottom of an EQ-CAB series cabinet if there is room.
- In a cabinet adjacent to the cabinet that holds a DS-AMP, with connections in conduit.

Within the CAB-4 Enclosure

Place the batteries in the bottom of the cabinet, as shown in Figure 3.5. Refer to “Batteries, Wiring” on page 39 for wiring instructions.

Outside the DS-AMP Enclosure

Batteries may be installed outside the DS-AMP enclosure, within the same room and within 20 feet (6.1 m) of the DS-AMP enclosure. The battery cables must be in conduit between the enclosures for the batteries and the DS-AMP. Refer to “Batteries, Wiring” on page 39 for wiring instructions.

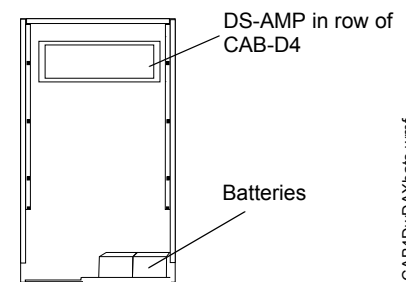

Figure 3.5 Battery Installation Within the Cabinet

3.5.3 Wiring

AC Power: TB4



WARNING: High Voltages Present.

Use extreme caution when working with the DS-AMP. High voltage and AC line-connected circuits are present. Turn off and remove all power sources. To reduce the risk of electric shock, make sure to properly ground the DS-AMP.

Close the hinged cover for TB4 after wiring but before energizing.

The DS-AMP power supply requires connection to a separate dedicated AC branch circuit. Follow these guidelines when connecting the AC branch circuit:

- Label the branch circuit “Fire Alarm”.
- Connect the branch circuit to the line side of the main power feed of the protected premises.
- Do not power other equipment from the fire alarm branch circuit.
- Run the AC branch circuit wire continuously, without any disconnect devices, from the power source to the power supply.
- Overcurrent protection for the AC branch circuit must comply with Article 760 of the National Electrical Codes, as well as local codes.
- Use 12-14 AWG (1.6mm O.D.) wire with 600 VAC insulation for the AC branch circuit.

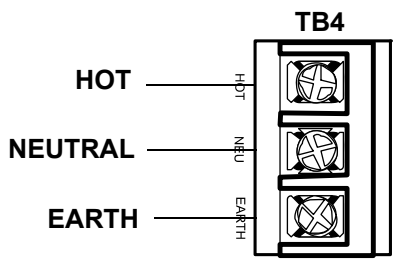

Figure 3.6 AC Power Connection

Connect primary power as follows:

1. Turn off the circuit breaker at the main power distribution panel.
2. Connect the earth ground terminal (TB1 EARTH) to a solid earth ground (a metallic, cold water pipe may be suitable in some installations). This connection is vital to maintaining the power supply’s immunity to unwanted transients generated by lightning and electrostatic discharge.
3. Connect the primary power neutral line to the terminal marked NEUTRAL and the primary power AC line to the terminal marked HOT.

Batteries, Wiring



WARNING: Do not connect the battery interconnect cable (See Figure 3.7) at this time. Leave the battery interconnect cable disconnected until after initial system power-up.

Battery cables (90”, 2.28 m) are included with the DS-AMP for battery installation in any CAB-4 series cabinet that includes a DS-AMP in one of the rows. Batteries may be installed in the bottom row of an EQ Series cabinet if there is room. For battery sharing, use 12 AWG wire either in the same cabinet, or in conduit for no more than 20 ft. (6.1 m.).



NOTE: Batteries must also be connected to a UL 864 listed charging power supply rated for the battery requirements of the specific application. The charging power supply must provide ground fault detection, and it must be monitored by a fire panel.

■ Batteries Within the Same Enclosure

Refer to Figure 3.7 for battery connections.

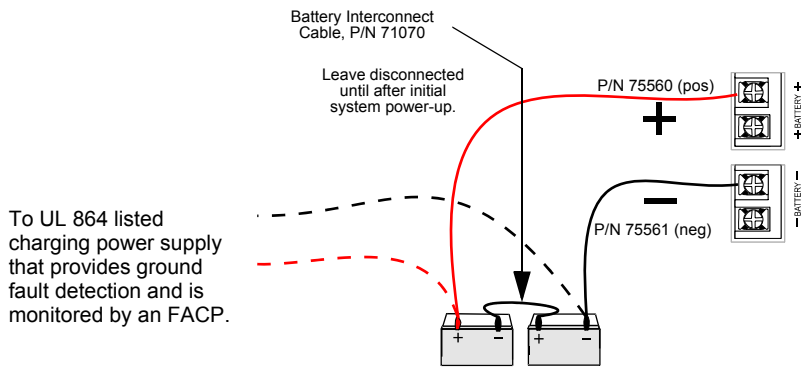

Figure 3.7 Connecting Batteries to TB5 and TB6

■ Batteries Outside the DS-AMP Enclosure

When batteries are installed outside the DS-AMP cabinet, connections are the same as in Figure 3.7. However, the battery cables between the two enclosures must be in conduit and the enclosures must be within 20 feet (6.9 m) of each other within the same room.

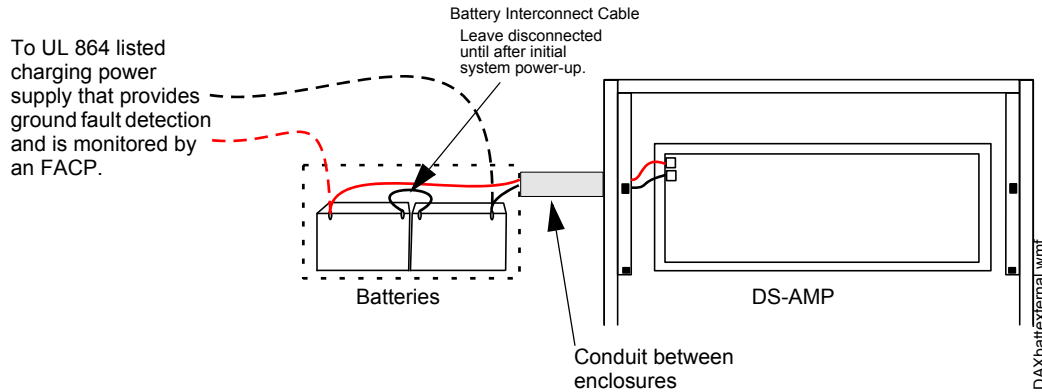

Figure 3.8 Using Conduit

DS-BUS: TB1

This connection provides basic non-audio communication between a DS-AMP and its DS-DB.

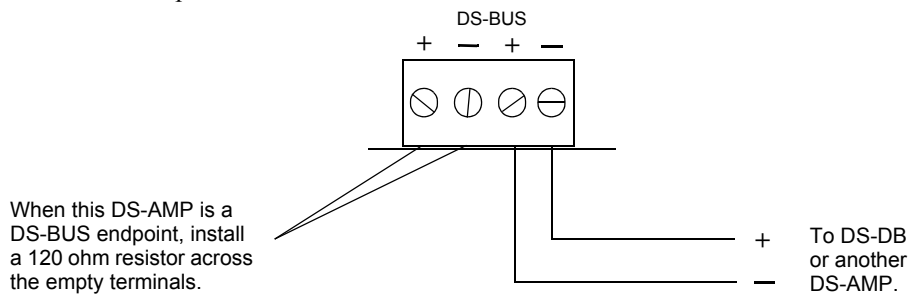

Figure 3.9 DS-BUS Connections

Refer to “DS-BUS, TB17” on page 21 for more information on the DS-BUS.

AUDIO IN: TB2

The AUDIO IN connections receive low level audio from the DS-DB. Low level audio can also be passed through to a backup DS-BDA or DS-AMP backup amplifier.

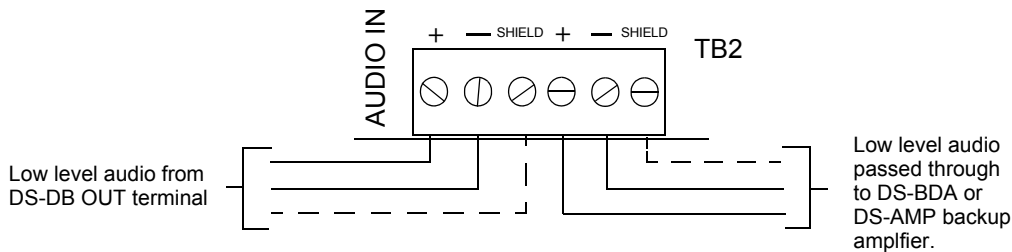

Figure 3.10 Low Level Audio IN

Connect the shield at one end in noisy environments, when the noise might couple onto the speaker wires, or audio from the speaker wires might couple onto another set of wires.

HIGH LEVEL OUTPUT: TB3

High level audio is sent out through these connections back to the DS-DB for speaker circuit routing. For 70V operation, the transformer (p/n DS-XF70V) needs to be connected to J1.

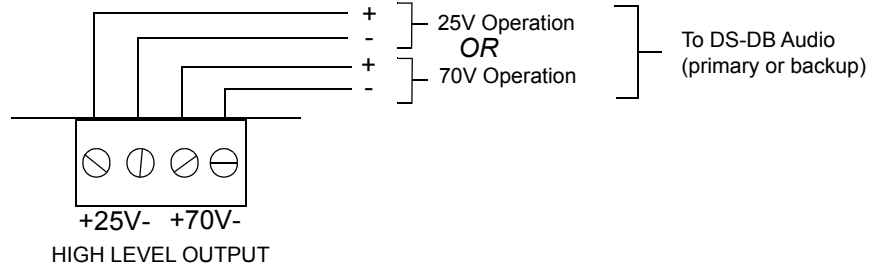

Figure 3.11 High Level Audio OUT

Wiring Fault Testing

Test wire-to-wire faults with 0 (zero) ohm impedance.

UL Power Limiting (Class 2) Requirements

Refer to “UL Power-limited (Class 2) Wiring Requirements” on page 29 for an illustration of these requirements.

3.5.4 Address Switch - SW1

Up to four DS-AMP amplifiers may be connected to a DS-DB. Each amplifier must be assigned a separate address (1, 2, 3 or 4) using the address switch.

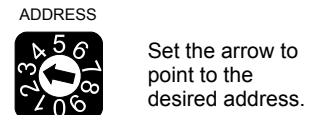

Figure 3.12 Address Switch

Section 4: DS-BDA Backup Amplifiers

The DS-BDA backup amplifiers provide an economical means of backing up DS-AMP amplifiers in a one-to-one primary/backup configuration. A DS-BDA can also provide a second audio channel for a DS-AMP when programmed as a primary amplifier in VeriFire Tools. Table 4.1 lists DS-BDA amplifier model.

DS-BDA		
DS-BDA	25 V _{RMS} or 70 V _{RMS} *	Compatible with DS-AMP
* 70 V _{RMS} option requires step-up transformer, p/n DS-XF70V, ordered separately.		

Table 4.1 DS-BDA Amplifier Models

A DS-BDA is not addressable: it is considered a part of the amplifier to which it is attached.

4.1 Features

- Programmable with VeriFire Tools to be either a backup or a primary amplifier.
- Provides backup for DS-AMP.
- Provides second audio channel for DS-AMP.

4.2 Specifications

DS-BDA card as backup

Audio output from the DS-AMP: 125 watts at 25V_{RMS} or 100 watts at 70V_{RMS}

OR

Audio output from the DS-BDA: 125 watts at 25V_{RMS} or 100 watts at 70V_{RMS}.

DS-BDA card as second channel

Power dynamically shared between DS-AMP and its BDA: 125 watts at 25V_{RMS} or 100 watts at 70V_{RMS}.

DS-AMP and DS-BDA must be in the same group.

Audio In, TB1

Power-limited (Class 2) at source.

Recommended wiring: 14-18 AWG, twisted-pair, unshielded.

Audio Out, TB2

Non-power-limited output.

Supervision programmable with DS-DB programming.

Recommended wiring: 14-18 AWG, twisted-pair, unshielded.

4.3 Board Layout

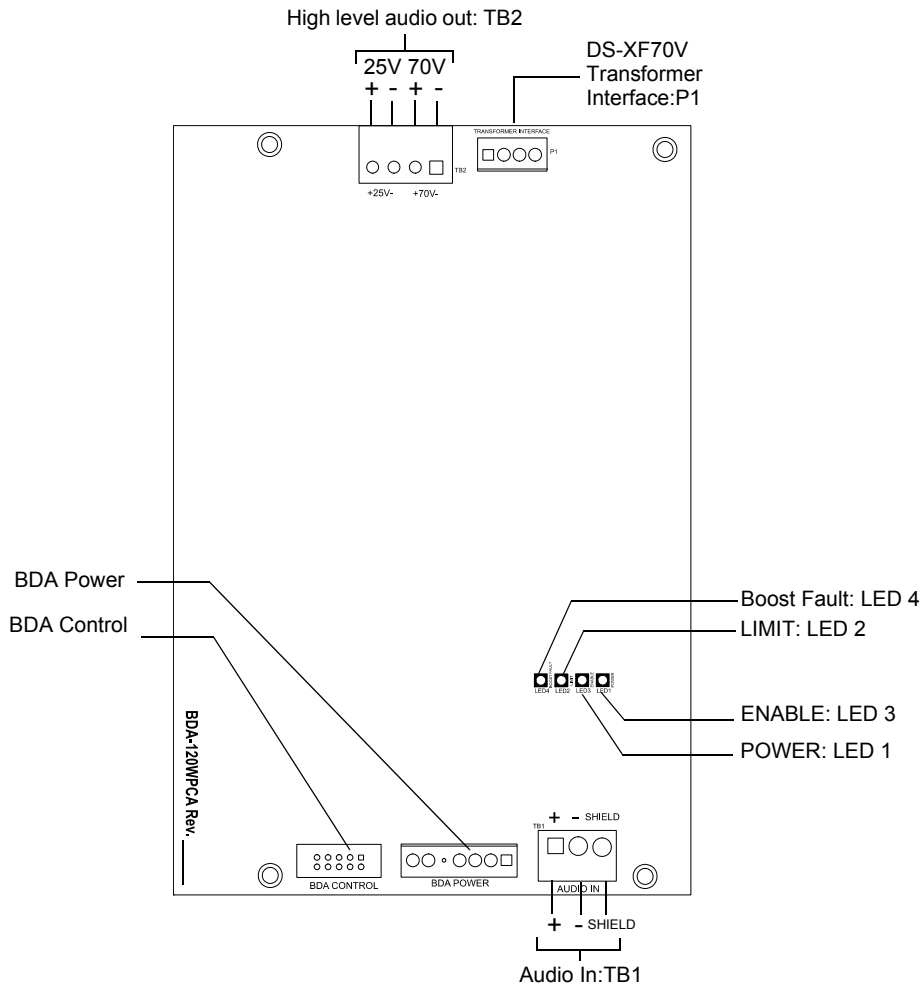

Figure 4.1 DS-BDA Layout

LED #	NAME	COLOR	DESCRIPTION
1	Power	Green	Illuminates when power is applied.
2	Limit	Yellow	Illuminates when output current is limited. The amplifier is overloaded.
3	Enable	Green	Illuminates when amplifier is enabled.
4	Boost Fault	Yellow	Illuminates when boost voltage is not present. Board is defective and should be returned.

Table 4.2 DS-BDA LED Indicators

4.4 Installation

The DS-BDA mounts on standoffs in the right side of the DS-AMP chassis. If the DS-AMP is configured for 70V operation, the transformers (p/n DS-XF70V, each ordered separately) are installed underneath the DS-BDA.

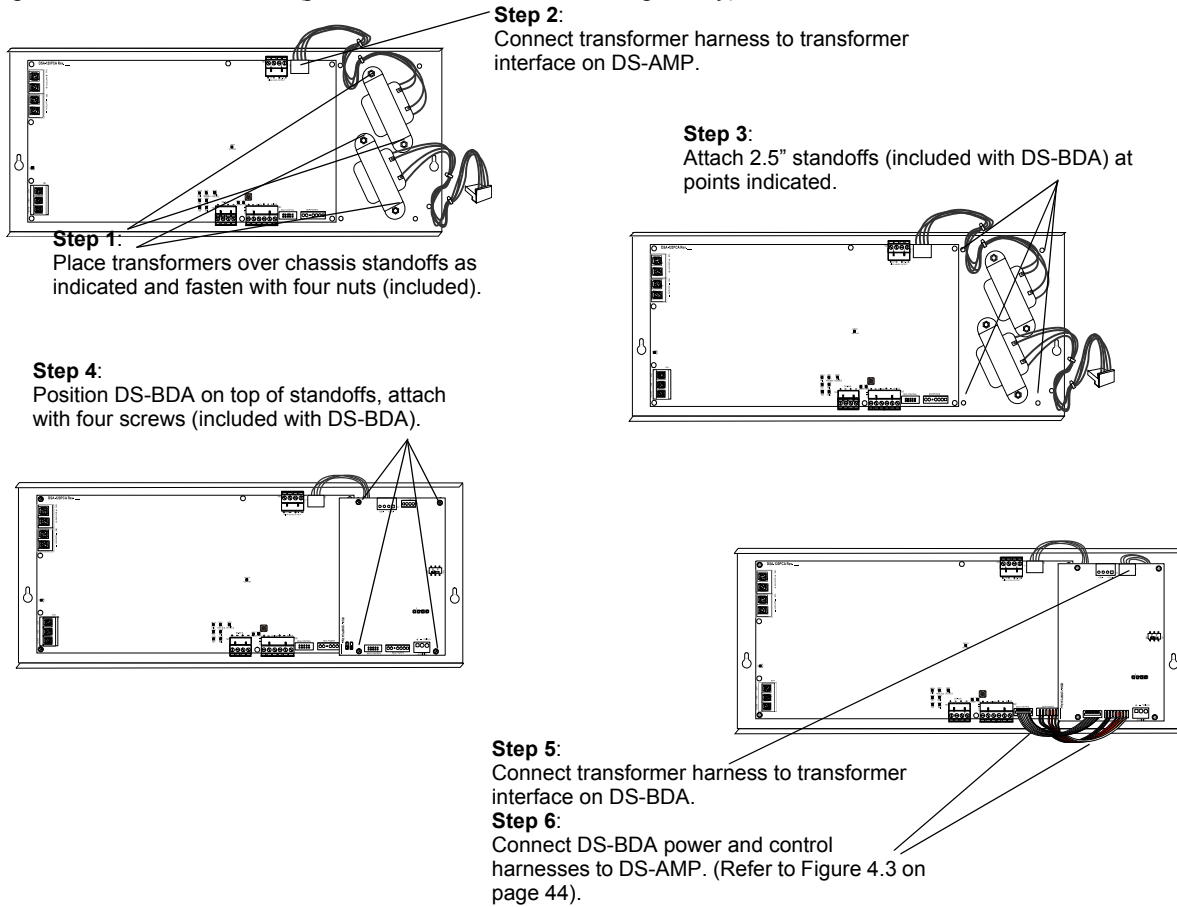

Figure 4.2 DS-BDA Installation with Transformers

DS-BDA Power and Control Cables

The BDA control and power cables are included with the DS-BDA.

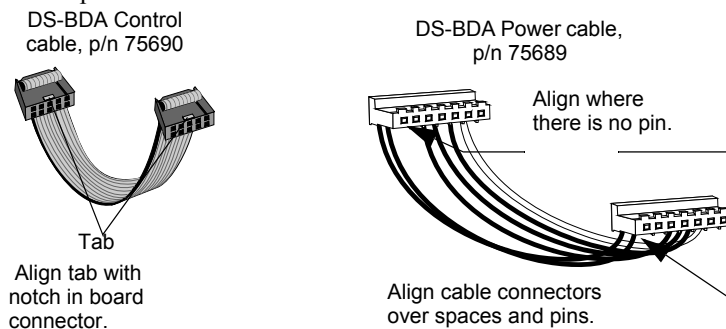

Figure 4.3 BDA Control and Power Cables

The DS-BDA is compatible with the DS-AMP and DS-AMPE audio amplifiers.

A transformer kit, p/n DS-XF70V, is required for 70V operation, and is ordered separately.

4.5 Wiring

Low Level Audio In: TB1

These connections provide an input for low level audio information from the DS-DB.



Figure 4.4 Low Level AUDIO IN

Connect the shield at one end in noisy environments, when the noise might couple onto the speaker wires, or audio from the speaker wires might couple onto another set of wires.

High Level Audio Out: TB2

High level audio is sent out through these connections back to the DS-DB for speaker circuit routing.

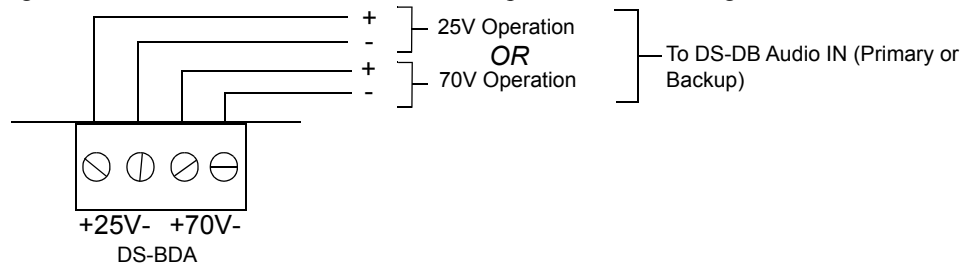

Figure 4.5 High Level Audio OUT

Wiring Fault Testing

Test wire-to-wire faults with 0 (zero) ohm impedance.

4.6 Operation

To simulate an amplifier failure, disconnect the audio input or output.

Section 5: DS-FM, DS-SFM and DS-RFM Fiber Option Modules

The DVC-PCC and all other DAL devices except fiber DAA amplifiers support wire media as shipped. The use of fiber optic media requires the use of fiber option modules. Each DAL device can be used with either one or two modules. This flexibility allows for the creation of digital audio networks with mixed wire, multi-mode fiber, and single-mode fiber segments on the same loop.

Fiber option modules consist of the following models:

Model	Fiber Type	For direct fiber connection between....	Not Used on
DS-FM	multi-mode	Two DAL devices	Single or multi-mode DVC-PCA, DVC-PCB or DAA.
DS-SFM	single-mode	Two DAL devices. An ST® style connector is required at a single-mode DVC/DAA end.	Multi-mode DVC-PCA, DVC-PCB or DAA.
DS-RFM	multi-mode	Two DAL devices, one of which is a multi-mode fiber DVC or DAA. An ST® style connector is required at the multi-mode DVC/DAA end.	Single-mode DVC-PCA, DVC-PCB or DAA.

Table 5.1 Fiber Option Module Models



NOTE: Whenever a fiber option module is used on a DAL device port, the next DAL device that is linked to that port must have the same model fiber option module (with the exception of single- and multi-mode DVCs and DAAs).

One or two fiber option modules may be connected to a DS-DB board to convert it from a board with two wire DAP ports to:

- a board with one wire and one fiber port,
- a board with two single-mode fiber ports,
- a board with two multi-mode fiber ports, or
- a board with one single-mode and one multi-mode fiber port.

When a fiber option module is mounted on a DS-DB, it disables the corresponding wire terminals.

- TB18 (DAP A, digital audio port A) is disabled when a fiber option board is connected at J3.
- TB19 (DAP B, digital audio port B) is disabled when a fiber option board is connected at J4.

5.1 Specifications

Single- and Multi-mode Fiber-Optic Digital Audio Ports

LC Style connection.

Supervised.

Fiber optic cable, multi-mode: 50/125 or 62.5/125 micrometers.

Fiber optic cable, single-mode: 9/125 micrometers.

Attenuation of cabling between two nodes (fiber-optic circuits are point-to-point) must not exceed the maximum attenuation, specified below.

To determine attenuation:

1. Find the rated dB loss per foot within the cable manufacturer's specifications. Determine the total attenuation between the two nodes due to the cable.
Loss = (loss/ft.) x (length in feet)
2. Establish the dB loss for each connector and splice. Sum all the losses.
3. Total the attenuation factors obtained in steps 1 and 2. This will provide an approximate attenuation total. The actual attenuation can be measured end-to-end with fiber-optic industry standard equipment.

DS-FM and DS-SFM

The maximum attenuation:

- 6.5dB for multi-mode with 50/125 micrometer cable @ 1310 nm.
- 10dB for multi-mode with 62.5/125 micrometer cable @ 1310 nm.
- 30dB for single-mode with 9/125 micrometer cable @ 1310 nm.

DS-SFM/Single-mode fiber DVC/DAA Connection

The maximum attenuation:

- 17dB for single-mode with 9/125 micrometer cable at 1310 nm going *from* the DS-SFM *to* the fiber DVC or fiber DAA.
- 4db for single-mode with 9/125 micrometer cable going *from* the fiber DVC or fiber DAA *to* the DS-SFM.

The minimum attenuation:

- 12dB going *from* the DS-SFM *to* the fiber DVC or fiber DAA.

Refer to Figure 5.3 on page 48 for an illustration.

DS-RFM/Multi-mode fiber DVC/DAA Connection

Attenuation going *from* the fiber DVC or fiber DAA *to* the DS-RFM:

- 2dB maximum for multi-mode with 50/125 micrometer cable @ 850 nm for the DS-RFM.
- 4dB maximum for multi-mode with 62.5/125 micrometer cable @ 850 nm for the DS-RFM.

Attenuation going *from* the DS-RFM *to* the fiber DVC or fiber DAA:

- 12dB minimum*, 16dB maximum for both cable types.

*If the length of the fiber run results in an attenuation of less than 12dB, a suitable attenuator must be used.

Refer to Figure 5.4 on page 49 for an illustration.

5.2 Layout

The DS-FM, DS-SFM and DS-RFM look the same. The silkscreened board names that do not apply will be crossed off at the time of manufacture.

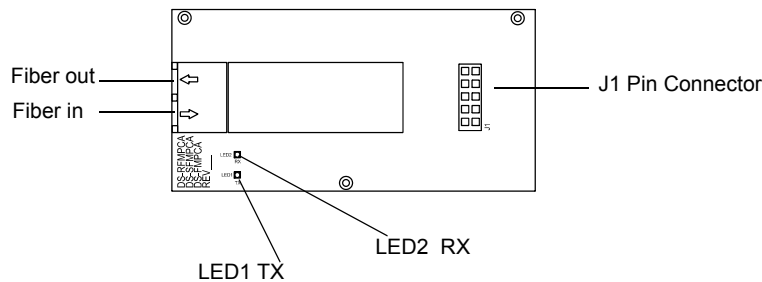

Figure 5.1 Fiber Option Conversion Module

LED #	NAME	COLOR	DESCRIPTION
1	TX	Green	Illuminates while data is transmitted on the digital audio port. Light will flicker, turning on when activity is detected and off when it is not.
2	RX	Green	Illuminates while data is received on the digital audio port. Light will flicker, turning on when activity is detected and off when it is not.

Table 5.2 DS-FM LED Indicators

5.3 Installation

With the DS-DB de-energized, install the fiber option modules as indicated in Figure 5.2.

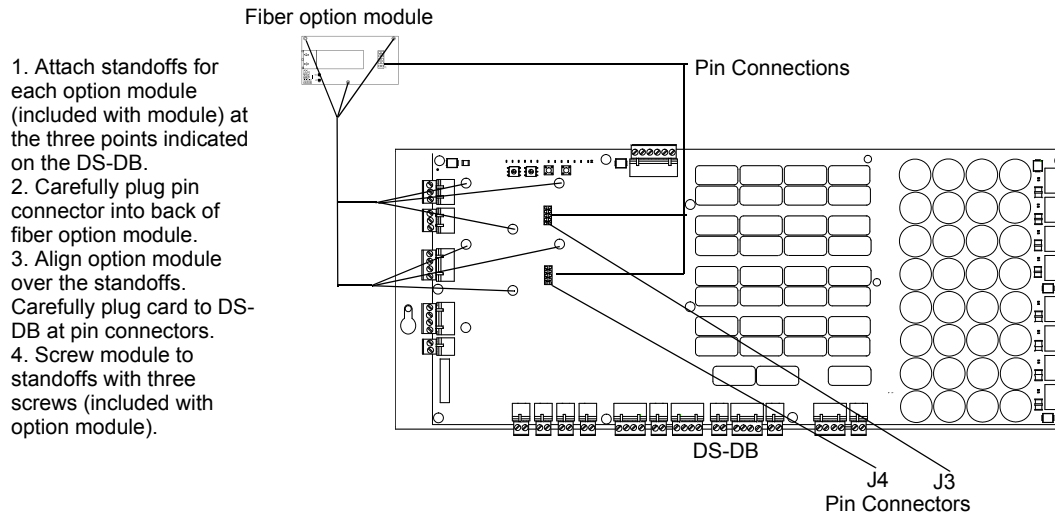

Figure 5.2 DS-DB Fiber Option Module Installation

5.4 Single- or Multi-mode DVC or DAA Installation

5.4.1 Single-mode

A single-mode fiber DVC or DAA is compatible with the DS-DB with a DS-SFM. The single-mode cable used to connect the DS-DB and DVC or DAA must have one ST Style Connector (required for the DVC or DAA) and one LC Style Connector (required for the DS-DB). Refer to Figure 5.3.

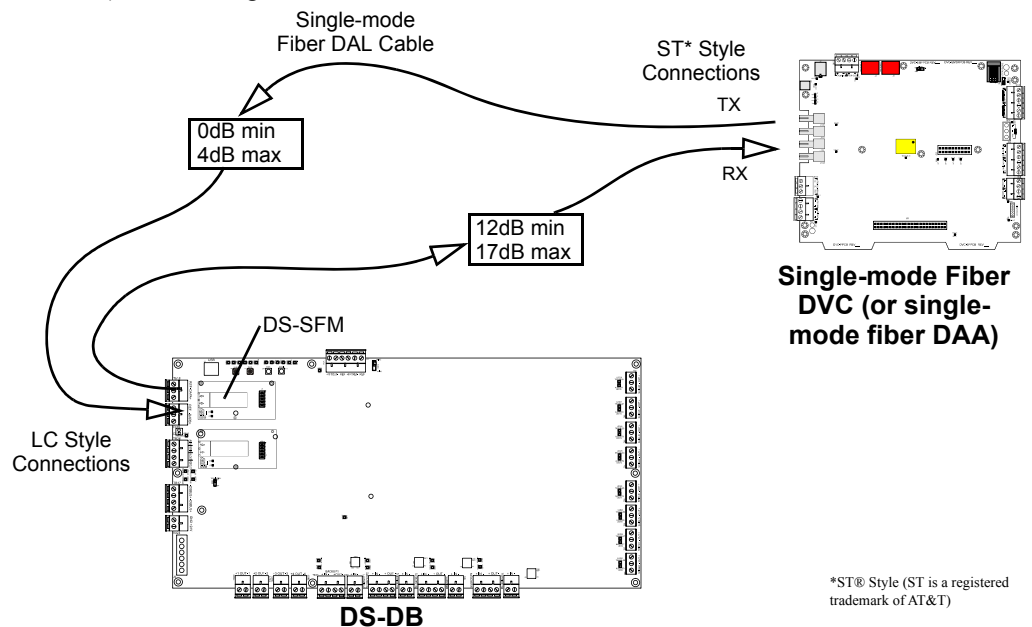

Figure 5.3 Single-mode Fiber DVC or DAA Installation

*ST® Style (ST is a registered trademark of AT&T)

5.4.2 Multi-mode

A DS-RFM must be used to connect a DS-DB to a multi-mode fiber DVC or DAA.

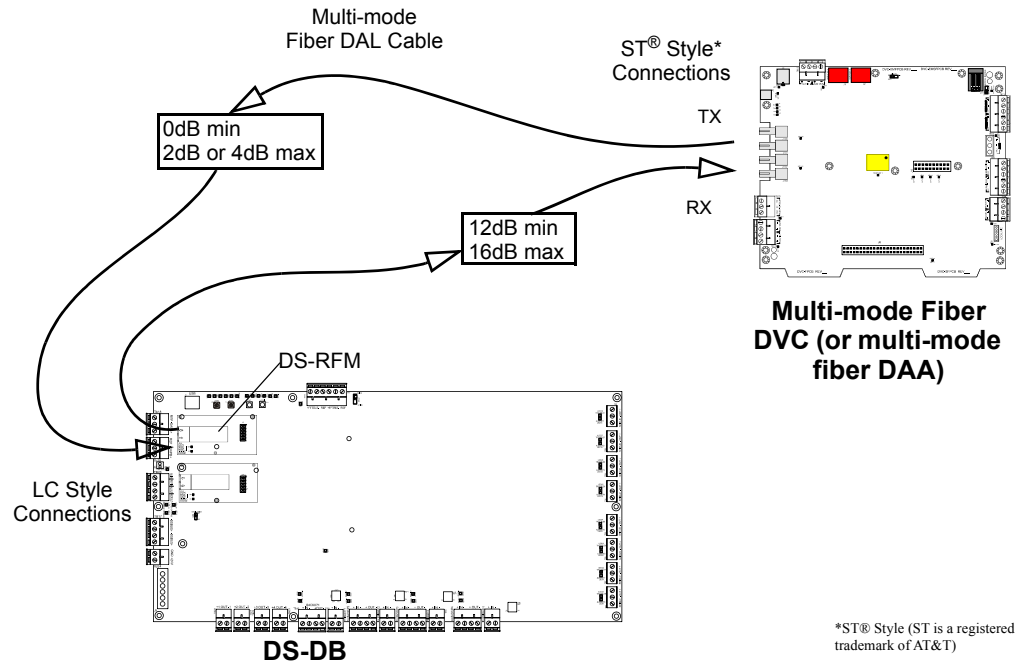

Figure 5.4 Multi-mode Fiber DVC or DAA Installation

Appendix A: DS-DB and DS-AMP Battery Calculations

Description	Column A Amps in Standby			Column B Amps in Alarm		
	QTY	X current draw =	Total	QTY	X current draw =	Total
DS-DB*	1	X [0.355A] =	0.355A	1	X [0.550A] =	0.550A
DS-FM (all models)	[]	X [0.060A] =		[]	X [0.060A] =	
24V Auxiliary Power (TB24 on DS-DB)**	[]	X [] =		[]	X [] =	
DS-AMP (25V)	[]	X [0.125A] =		[]	X [0.280A] =	
DS-BDA (25V)	[]	X [0.100A] =		[]	X [0.300A] =	
DS-AMP (70V)	[]	X [0.130A] =		[]	X [0.300A] =	
DS-BDA (70V)	[]	X [0.105A] =		[]	X [0.330A] =	
AMPS-24***	[]	X [0.130A] =		[]	X [0.130A] =	
Speakers:						
1/4 watt				[]	X [0.016A] =	
1/2 watt				[]	X [0.031A] =	
3/4 watt				[]	X [0.047A] =	
1 watt				[]	X [0.062A] =	
2 watt				[]	X [0.124A] =	
Other _____	[]	X [] =		[]	X [] =	
		Total Column A	_____		Total Column B	_____
<p>* Includes FFT Riser Draw ** Refer to the documentation that comes with the device(s) being powered through the DS-DB's TB24 for standby and alarm figures. ***If the AMPS-24 is powering additional components, refer to the AMPS-24 manual for standby and alarm figures.</p>						

Table A.1 Current Draw Calculations for DS-DB and DS-AMP

Load Totals		Multiplied By	Time	Equals	Secondary Amp Hour Totals		
Enter total from Column A in Table A.1. (Standby Load)	[]	X	Required Secondary Non-fire Alarm Standby Time (24 or 60 hours)	[]	=	[]	Non-fire Alarm Secondary Standby Amp Hours
Enter total from Column B in Table A.1. (Alarm Load)	[]	X	Required Fire Alarm Time in Decimal Form*	[]	=	[]	Secondary Fire Alarm Amp Hour Requirement
Sum column for Total Secondary Ampere Hours (AH) Calculated					=		
Multiply by the derating factor X 1.2					=	[]	Total Secondary Amp Hours Required
*Following are decimal conversions for standard numbers of minutes:							
5 minutes	0.084						
10 minutes	0.167						
15 minutes	0.250						
30 minutes	0.50						
60 minutes	1.0						
Standby operating times:							
<ul style="list-style-type: none"> NFPA 72 Local, Proprietary, Auxiliary, Remote Station, and Central Station systems require 24 hours of standby power followed by 5 minutes in alarm. Some jurisdictions require 60 hours of standby power followed by 5 minutes in alarm for Auxiliary and Remote Station systems, based on previous NFPA 72 requirements. 24 hours of standby/supervisory condition followed by 2 hours of alarm. 							

Table A.2 Secondary Power Standby and Fire Alarm Load

Battery Size	Voltage Rating	Required Number	Model Number
7 AH	12 volt	Two	BAT-1270
12 AH	12 volts	Two	BAT-12120
26 AH	12 volts	Two	BAT-12260
55 AH	12 volts	Two	BAT-12550

Table A.3 Battery Size Requirements

Notes

Index

Numerics

120 ohm resistor **21**
2Wire/4Wire Switch **32**
75637, AMPS-24 cable **17**
75689, BDA Power Cable **44**
75690, BDA Control Cable **44**

A

Address
 BDA **42**
 DS-AMP **7**
 Rotary switch **35, 41**
 DS-BDA **22**
 DS-BUS, programming, refer to Digital Voice Command manual.
 DS-DB **7, 18**
 Rotary switches **14, 31**
AFAWS **20, 21**
AIM-1 **27, 28**
Alarm Bus **10, 17**
Amplified high-level audio input **23, 24, 25**
Audio Outputs, low level **23, 24, 25**
Auxiliary Power **17**

B

Backup Amplifier
 Compatibility **7**
Batteries
 Cables **39**
 DS-AMP
 Installation **38**
 Wiring **39**
 Size requirements **51**
Battery Calculations **50**

C

CAB-4 Series Cabinets **15, 35**
Cables for DS-BDA **44**
CAUTION
 Do not mix voltages within a group... **31**
CIM/CSM **28**

D

DAL **18**
 Block Diagram **7**
DAPs
 Class X, Class B **19**
 Wiring **18**
Disable DS-DB speaker circuit **32**
DP-1B Dress Panel **16, 37**
DS-AMP **33, 36**
 Features **33**
 Layout **34**
 LEDs and Switches **35**
 Number per DS-DB **33**
 Series Models **33**
 Specifications **33**
 Switch, Address **41**
 Wiring

AC Power **38**
Audio In **40**
Batteries **39**
DS-BUS **40**
 High level output **41**

DS-BDA 42

 as second audio channel **42**
 Compatibility **44**
 Features **42**
 Installation **44**
 Layout **43**
 LED Indicators **43**
 Operation **45**
 Power and Control Cables **44**
 Specifications **42**
 Wiring
 High Level Audio Out **45**
 Low Level Audio In **45**

DS-BUS

 AMPS-24 board requirements **21**
 common ground **21**
 Endpoints **21**
 wiring **21**

DS-DB

 2Wire/4Wire Switch **32**
 Disable speaker circuit **32**
 Features **9**
 Layout **11**
 LED Indicators **11**
 Local Silence Switch **31**
 Power through harness or TB24 **17**
 Specifications **9**
 Switches **14**
 Termination Switch **31**
 Voltage Selection Switches **31**
 Wiring
 Audio Out, Speaker Circuits **25**
 DAPs **18**
 DS-BUS **21**
 DVC-AO level audio OUT **23**
 FFT Riser **20**
 Primary and Backup **23**
 Riser Modes **26**

DS-FM 46

DS-RFM **46, 47**

DS-SFM 46

DS-XF70V, step-up transformer **33, 42, 44**

E

Endpoint, See DS-BUS
EQ Series backboxes and doors **15, 35**

F

FCM-1 **18**

FFT Riser

 Wiring **20**

Fiber option modules **7, 46**

 Installation **48**

 Layout **47**

Fiber/wire DAL **20**

FPJ **21**
FPJ-1 **21**
FTM-1 **20**

G

Group
 do not mix voltages **31**

H

Heat Dissipation - See Heat Dissipation Calculation document listed in related documentation chart.

L

Local Silence Switch **31**

M

Mixed wire/fiber DALs **19**

N

NCA-2 **32**
NFS2-3030 **32**

O

One-to-Many Backup **25**
One-to-One Backup **24**

P

Power-limited Requirements **29**

R

R-10k **26**
R-3.9k **20**
Read Status **32**
Read/Alter Status **32**
Riser Modes **26**
 Groups **26**
RSM-1 **27**

S

Specifications
 DS-AMP **33**
 DS-DB **9**
 Fiber option modules **46**

T

Telephone control **20**
Telephone Control Module **21**
Termination Switch **31**
Test Switch **32**
Transformer, step-up, for 70vrms models **33, 42, 44**
Trouble Messages **32**

U

UL Power-limited Requirements **29**

V

VeriFire Tools **23, 26, 32, 42**
Voltage Selection Switches **31**

W

WARNING

Batteries contain sulfuric acid.... **38**
Do not connect battery interconnect cable
until after initial system power-
up. **39**
High Voltages Present.... **38**
Wear a static discharge wrist strap... **15, 36**

Wire/fiber DAL **20**

Wiring

Digital Audio Ports A and B **18**
DS-AMP power supply to AC Power **38**
FFT Riser **20**

Manufacturer Warranties and Limitation of Liability

Manufacturer Warranties. Subject to the limitations set forth herein, Manufacturer warrants that the Products manufactured by it in its Northford, Connecticut facility and sold by it to its authorized Distributors shall be free, under normal use and service, from defects in material and workmanship for a period of thirty six months (36) months from the date of manufacture (effective Jan. 1, 2009). The Products manufactured and sold by Manufacturer are date stamped at the time of production. Manufacturer does not warrant Products that are not manufactured by it in its Northford, Connecticut facility but assigns to its Distributor, to the extent possible, any warranty offered by the manufacturer of such product. This warranty shall be void if a Product is altered, serviced or repaired by anyone other than Manufacturer or its authorized Distributors. This warranty shall also be void if there is a failure to maintain the Products and the systems in which they operate in proper working conditions.

MANUFACTURER MAKES NO FURTHER WARRANTIES, AND DISCLAIMS ANY AND ALL OTHER WARRANTIES, EITHER EXPRESSED OR IMPLIED, WITH RESPECT TO THE PRODUCTS, TRADEMARKS, PROGRAMS AND SERVICES RENDERED BY MANUFACTURER INCLUDING WITHOUT LIMITATION, INFRINGEMENT, TITLE, MERCHANTABILITY, OR FITNESS FOR ANY PARTICULAR PURPOSE. MANUFACTURER SHALL NOT BE LIABLE FOR ANY PERSONAL INJURY OR DEATH WHICH MAY ARISE IN THE COURSE OF, OR AS A RESULT OF, PERSONAL, COMMERCIAL OR INDUSTRIAL USES OF ITS PRODUCTS.

This document constitutes the only warranty made by Manufacturer with respect to its products and replaces all previous warranties and is the only warranty made by Manufacturer. No increase or alteration, written or verbal, of the obligation of this warranty is authorized. Manufacturer does not represent that its products will prevent any loss by fire or otherwise.

Warranty Claims. Manufacturer shall replace or repair, at Manufacturer's discretion, each part returned by its authorized Distributor and acknowledged by Manufacturer to be defective, provided that such part shall have been returned to Manufacturer with all charges prepaid and the authorized Distributor has completed Manufacturer's Return Material Authorization form. The replacement part shall come from Manufacturer's stock and may be new or refurbished. THE FOREGOING IS DISTRIBUTOR'S SOLE AND EXCLUSIVE REMEDY IN THE EVENT OF A WARRANTY CLAIM.

Warn-HL-08-2009.fm

NOTIFIER
12 Clintonville Road
Northford, CT 06472-1610 USA
203-484-7161
www.notifier.com

