

58160D Wireless Outdoor Sensor – Quick Installation Guide

For Online Support visit: <http://www.security.honeywell.com/hsc/resources/MyWebTech/>

WARRANTY For the latest warranty information go to: <http://www.security.honeywell.com/hsc/resources/wa/>

General Information and Component Identification

The Honeywell 58160D Wireless Outdoor Sensor (referred to as the Sensor) brings the convenience of wireless technology to the outdoors.

- Weatherized security protection for an outdoor environment. Great for sheds, barns, garages, pool gates, fences, and rural mailbox (notifications). Can be painted.
- Cover and rear tamper detection.
- Operating Environment: - 40 to +66°C (- 40 to +150°F) at RH of 100% (UL: Rated at RH of 85%).
- Meets NEMA4X water protection.
- Sensor: 4-3/8" x 2-1/16" x 1-9/16"
Magnet: 4-1/16" x 15/16" x 1-7/32" with spacer.
- Maximum Magnet Gap: Wood 1.9 in., Steel 1.4 in.
- For extra wide gaps use the 7945-2GY external contact.
- (Always check installation to ensure there are no false alarms due to gap spacing.)
- For extended wireless range use the 5800RP (Repeater).
- UL: Approved for UL Commercial Burglary listed control panels (e.g., VISTA-50P) and receivers (e.g., 5881ENHC).

COMPONENT IDENTIFICATION

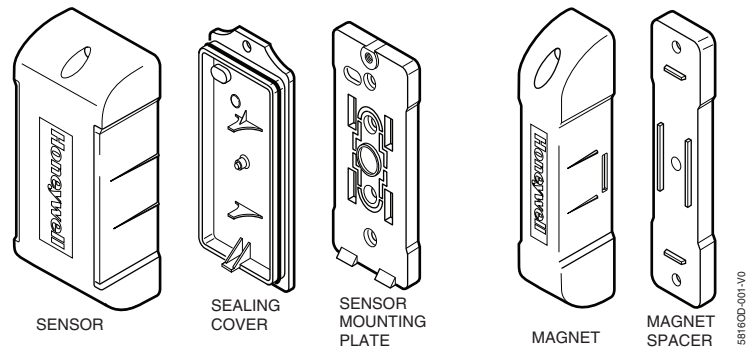

The 58160D has two unique zones; the Loop #1 is for a wired closed circuit contact loop and Loop #2 is for the built-in reed switch (used in conjunction with a magnet). Either or both zones may be used.

A built-in tamper switch is activated when the cover is removed, or if the Sensor is detached from its mounting.

Installing / Replacing the Batteries

IMPORTANT:

- Always change both batteries. Do not mix weak batteries with new batteries.
- Use two (2) lithium 1.5VDC AA cells. (For best life, use Eveready's **Energizer Ultimate LITHIUM** AA batteries, Honeywell part number 462) Alkaline batteries may be used but the battery life and temperature range will be reduced.
- OBSERVE BATTERY POLARITY.**

Battery Replacement:

- Remove cover screw and swing Sensor to remove from Sensor Mounting Plate.
- Use screwdriver in any pivot point and pry Sealing Cover off. Replace batteries.
- Orient the Sealing Cover so the screw hole lines up with the screw hole in the sensor cover, and press to close.
- Engage Sensor tabs into mating holes in Sensor Mounting Plate and swing closed. Secure with cover screw.

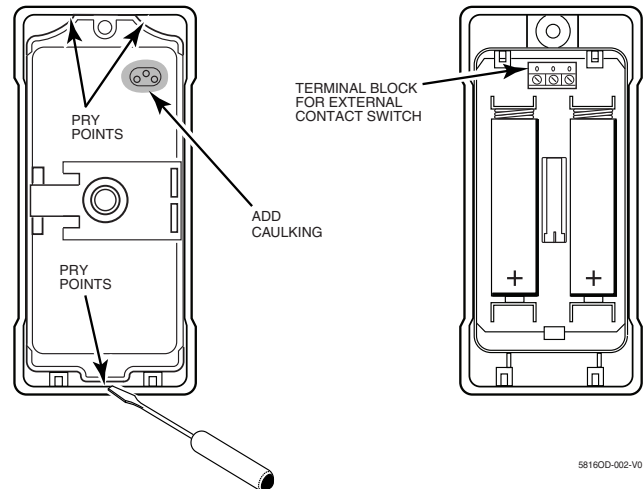

Mounting Guidelines

- Before mounting the Sensor permanently, conduct a Go/No Go test (see control panel's instructions) to verify adequate signal strength. Reorient, relocate, or use a repeater if necessary.
- This device is intended for vertical surfaces (to be mounted at a sufficient height) where snow, ice and water buildup will not interfere with its operation.
- Before final mounting, ensure water protection by ALWAYS adding silicone caulk to surround the rubber wire seal on the Sealing Cover.
- Mount the Magnet on the magnet sensing side of the Sensor as identified by the side ribs on the Sensor.
- Mount the Sensor on a **stationary** surface, and mount the Magnet on the **moveable** surface.
- Mount the Magnet parallel with the Sensor. Use the Magnet Spacer where necessary to make the Magnet top near level with the Sensor top.
- When used on wooden sheds and barns, it is recommended to mount the sensor and magnet on the inside of the structure when possible.
- Use screws suitable for the material being fastened to.
- UL: When mounting on curved surfaces, the Sensor and Magnet must be fastened by both strap ties and screws.

Tamper Protection:

The tamper switch is activated when either the cover is removed, or if the sensor is detached from its mounting.

In order for the tamper switch to sense if the sensor is detached from its mounting, you must secure the breakaway tab on the Sensor Mounting Plate.

FLAT SURFACES

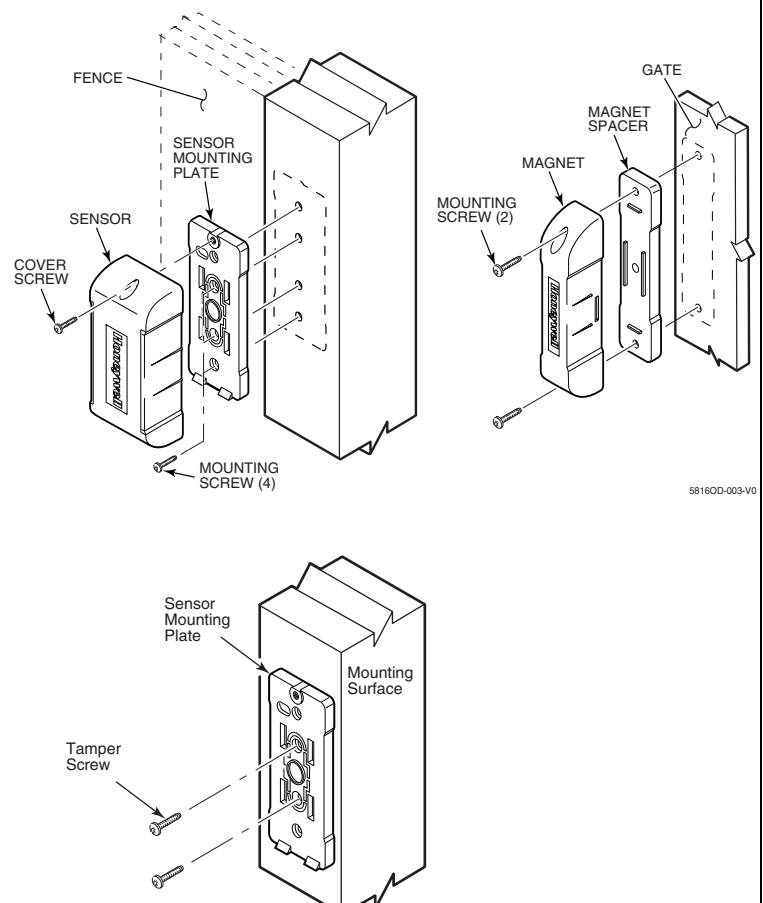

Curved Surfaces:

Suggested mounting hardware such as the strap ties and cable ties are not supplied.

- Mount using self locking stainless steel strap ties.



58160D-005-V0

Self Locking Stainless Steel Strap Tie

- Alternately you can use extra heavy duty **Nylon 6/6 UV and Temperature Rated** cable ties (0.5 inch wide).
- If desired you may use screws in addition to the ties.

CURVED SURFACES

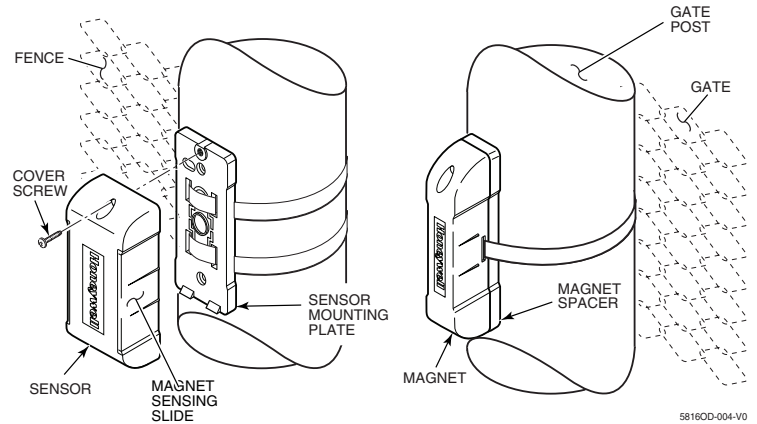

58160D-004-V0

ROUTING EXTERNAL WIRING – Optional for use with external closed contact switches, such as the Honeywell N7945-2GY:

Note: Use minimum of 22AWG jacketed cable. The contact switch must be a Form C (SPDT) type.

UL: Maximum wire length cannot exceed 3 feet.

1. Strip cable jacket back 4-inches to allow enough slack to remove Sealing Cover when changing batteries.
2. Pass cable through the access hole in Sensor Mounting Plate. Use cable notch on mounting plate to pass jacketed portion of cable through. Then attach the Sensor Mounting Plate.
3. Route cable to the external contact switch and fasten at intervals to secure cable.
4. Remove the Sealing Cover and thread wires through the rubber wire seal. If installed, REMOVE ANY BATTERIES.
5. Connect wires to terminal block in battery chamber, then INSTALL the batteries.
6. Replace the Sealing Cover. (Note, orient the cover so the screw hole lines up with the screw hole in the sensor cover, and press to close.) Apply silicone caulking to rubber wire seal.
7. Engage Sensor tabs into Sensor Mounting Plate mating holes and swing closed. Secure with cover screw.

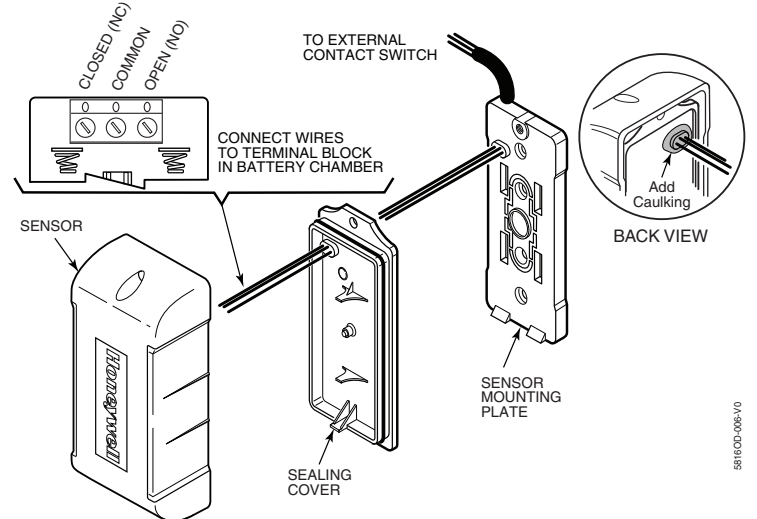

58160D-006-V0

PAINTING THE SENSOR:

The sensor and magnet may be painted to coordinate its color with the mounting surface. Use only paints that are made for plastic and follow the manufacturer's direction for preparing the plastic and applying the paint. Observe the required drying and curing times. DO NOT USE METALLIC PAINT COLORS.

Recommended Paints:

- Krylon® "Fusion for Plastic"
- Rust-Oleum® "Plastic"
- Dupli-Color® "Vinyl & Fabric Coating"

Programming the Control Panel

You must program the transmitter's serial number, input type (RF Supervised), response type, and loop # in the control panel. (Either or both loops may be used. Loop # 2 is for the magnet sensing, and Loop # 1 is for the external contact switch.) Refer to the control panel's guide for detailed information on zone programming and the programming of low battery, tamper and supervisory features.

Note: The transmitter's serial number may be found on the carton, and in the Battery Chamber.

Final Checkout

Ensure the following:

- All mounting hardware is secure.
- If mounted on curved surfaces, check that the Sensor or Magnet cannot rotate. Use mounting screws if necessary to correct this.
- Exercise the door or gate and check that physical tolerances do not exceed the allowable magnet gap.
- Perform multiple system tests exercising the door or gate to ensure there are no false alarms.

FCC / IC STATEMENT

This device complies with Part 15 of the FCC rules and RSS 210 of Industry Canada. Operation is subject to the following two conditions: (1) This device may not cause harmful interference, and (2) This device must accept any interference received, including interference that may cause undesired operation.

Cet appareil est conforme à la partie 15 des règles de la FCC & de RSS 210 des Industries Canada. Son fonctionnement est soumis aux conditions suivantes: (1) Cet appareil ne doit pas causer d'interférences nuisibles. (2) Cet appareil doit accepter toute interférence reçue y compris les interférences causant une réception indésirable.

FEDERAL COMMUNICATIONS COMMISSION STATEMENT

The user shall not make any changes or modifications to the equipment unless authorized by the Installation Instructions or User's Manual. Unauthorized changes or modifications could void the user's authority to operate the equipment.



800-04494V1 6/11 Rev. B

Honeywell

2 Corporate Center Drive, Suite 100
P.O. Box 9040, Melville, NY 11747

Copyright © 2011 Honeywell International Inc.
www.honeywell.com/security