

Network Systems Interface
NOTI•FIRE•NET[™]

Network Version 5.0



Fire Alarm & Emergency Communication System Limitations

While a life safety system may lower insurance rates, it is not a substitute for life and property insurance!

An automatic fire alarm system—typically made up of smoke detectors, heat detectors, manual pull stations, audible warning devices, and a fire alarm control panel (FACP) with remote notification capability—can provide early warning of a developing fire. Such a system, however, does not assure protection against property damage or loss of life resulting from a fire.

An emergency communication system—typically made up of an automatic fire alarm system (as described above) and a life safety communication system that may include an autonomous control unit (ACU), local operating console (LOC), voice communication, and other various interoperable communication methods—can broadcast a mass notification message. Such a system, however, does not assure protection against property damage or loss of life resulting from a fire or life safety event.

The Manufacturer recommends that smoke and/or heat detectors be located throughout a protected premises following the recommendations of the current edition of the National Fire Protection Association Standard 72 (NFPA 72), manufacturer's recommendations, State and local codes, and the recommendations contained in the Guide for Proper Use of System Smoke Detectors, which is made available at no charge to all installing dealers. This document can be found at <http://www.systemsensor.com/appguides/>. A study by the Federal Emergency Management Agency (an agency of the United States government) indicated that smoke detectors may not go off in as many as 35% of all fires. While fire alarm systems are designed to provide early warning against fire, they do not guarantee warning or protection against fire. A fire alarm system may not provide timely or adequate warning, or simply may not function, for a variety of reasons:

Smoke detectors may not sense fire where smoke cannot reach the detectors such as in chimneys, in or behind walls, on roofs, or on the other side of closed doors. Smoke detectors also may not sense a fire on another level or floor of a building. A second-floor detector, for example, may not sense a first-floor or basement fire.

Particles of combustion or "smoke" from a developing fire may not reach the sensing chambers of smoke detectors because:

- Barriers such as closed or partially closed doors, walls, chimneys, even wet or humid areas may inhibit particle or smoke flow.
- Smoke particles may become "cold," stratify, and not reach the ceiling or upper walls where detectors are located.
- Smoke particles may be blown away from detectors by air outlets, such as air conditioning vents.
- Smoke particles may be drawn into air returns before reaching the detector.

The amount of "smoke" present may be insufficient to alarm smoke detectors. Smoke detectors are designed to alarm at various levels of smoke density. If such density levels are not created by a developing fire at the location of detectors, the detectors will not go into alarm.

Smoke detectors, even when working properly, have sensing limitations. Detectors that have photoelectronic sensing chambers tend to detect smoldering fires better than flaming fires, which have little visible smoke. Detectors that have ionizing-type sensing chambers tend to detect fast-flaming fires better than smoldering fires.

Because fires develop in different ways and are often unpredictable in their growth, neither type of detector is necessarily best and a given type of detector may not provide adequate warning of a fire.

Smoke detectors cannot be expected to provide adequate warning of fires caused by arson, children playing with matches (especially in bedrooms), smoking in bed, and violent explosions (caused by escaping gas, improper storage of flammable materials, etc.).

Heat detectors do not sense particles of combustion and alarm only when heat on their sensors increases at a predetermined rate or reaches a predetermined level. Rate-of-rise heat detectors may be subject to reduced sensitivity over time. For this reason, the rate-of-rise feature of each detector should be tested at least once per year by a qualified fire protection specialist. Heat detectors are designed to protect property, not life.

IMPORTANT! Smoke detectors must be installed in the same room as the control panel and in rooms used by the system for the connection of alarm transmission wiring, communications, signaling, and/or power. If detectors are not so located, a developing fire may damage the alarm system, compromising its ability to report a fire.

Audible warning devices such as bells, horns, strobes, speakers and displays may not alert people if these devices are located on the other side of closed or partly open doors or are located on another floor of a building. Any warning device may fail to alert people with a disability or those who have recently consumed drugs, alcohol, or medication. Please note that:

- An emergency communication system may take priority over a fire alarm system in the event of a life safety emergency.
- Voice messaging systems must be designed to meet intelligibility requirements as defined by NFPA, local codes, and Authorities Having Jurisdiction (AHJ).
- Language and instructional requirements must be clearly disseminated on any local displays.
- Strobes can, under certain circumstances, cause seizures in people with conditions such as epilepsy.
- Studies have shown that certain people, even when they hear a fire alarm signal, do not respond to or comprehend the meaning of the signal. Audible devices, such as horns and bells, can have different tonal patterns and frequencies. It is the property owner's responsibility to conduct fire drills and other training exercises to make people aware of fire alarm signals and instruct them on the proper reaction to alarm signals.
- In rare instances, the sounding of a warning device can cause temporary or permanent hearing loss.

A life safety system will not operate without any electrical power. If AC power fails, the system will operate from standby batteries only for a specified time and only if the batteries have been properly maintained and replaced regularly.

Equipment used in the system may not be technically compatible with the control panel. It is essential to use only equipment listed for service with your control panel.

Telephone lines needed to transmit alarm signals from a premises to a central monitoring station may be out of service or temporarily disabled. For added protection against telephone line failure, backup radio transmission systems are recommended.

The most common cause of life safety system malfunction is inadequate maintenance. To keep the entire life safety system in excellent working order, ongoing maintenance is required per the manufacturer's recommendations, and UL and NFPA standards. At a minimum, the requirements of NFPA 72 shall be followed. Environments with large amounts of dust, dirt, or high air velocity require more frequent maintenance. A maintenance agreement should be arranged through the local manufacturer's representative. Maintenance should be scheduled as required by National and/or local fire codes and should be performed by authorized professional life safety system installers only. Adequate written records of all inspections should be kept.

Limit-D2-2016

Installation Precautions

Adherence to the following will aid in problem-free installation with long-term reliability:

WARNING - Several different sources of power can be connected to the fire alarm control panel. Disconnect all sources of power before servicing. Control unit and associated equipment may be damaged by removing and/or inserting cards, modules, or interconnecting cables while the unit is energized. Do not attempt to install, service, or operate this unit until manuals are read and understood.

CAUTION - System Re-acceptance Test after Software

Changes: To ensure proper system operation, this product must be tested in accordance with NFPA 72 after any programming operation or change in site-specific software. Re-acceptance testing is required after any change, addition or deletion of system components, or after any modification, repair or adjustment to system hardware or wiring. All components, circuits, system operations, or software functions known to be affected by a change must be 100% tested. In addition, to ensure that other operations are not inadvertently affected, at least 10% of initiating devices that are not directly affected by the change, up to a maximum of 50 devices, must also be tested and proper system operation verified.

This system meets NFPA requirements for operation at 0-49° C/ 32-120° F and at a relative humidity 93% ± 2% RH (non-condensing) at 32°C ± 2°C (90°F ± 3°F). However, the useful life of the system's standby batteries and the electronic components may be adversely affected by extreme temperature ranges and humidity. Therefore, it is recommended that this system and its peripherals be installed in an environment with a normal room temperature of 15-27° C/60-80° F.

Verify that wire sizes are adequate for all initiating and indicating device loops. Most devices cannot tolerate more than a 10% I.R. drop from the specified device voltage.

Like all solid state electronic devices, this system may operate erratically or can be damaged when subjected to lightning induced transients. Although no system is completely immune from lightning transients and interference, proper grounding will reduce susceptibility. Overhead or outside aerial wiring is not recommended, due to an increased susceptibility to nearby lightning strikes. Consult with the Technical Services Department if any problems are anticipated or encountered.

Disconnect AC power and batteries prior to removing or inserting circuit boards. Failure to do so can damage circuits.

Remove all electronic assemblies prior to any drilling, filing, reaming, or punching of the enclosure. When possible, make all cable entries from the sides or rear. Before making modifications, verify that they will not interfere with battery, transformer, or printed circuit board location.

Do not tighten screw terminals more than 9 in-lbs. Over-tightening may damage threads, resulting in reduced terminal contact pressure and difficulty with screw terminal removal.

This system contains static-sensitive components. Always ground yourself with a proper wrist strap before handling any circuits so that static charges are removed from the body. Use static suppressive packaging to protect electronic assemblies removed from the unit.

Units with a touchscreen display should be cleaned with a dry, clean, lint free/microfiber cloth. If additional cleaning is required, apply a small amount of Isopropyl alcohol to the cloth and wipe clean. Do not use detergents, solvents, or water for cleaning. Do not spray liquid directly onto the display.

Follow the instructions in the installation, operating, and programming manuals. These instructions must be followed to avoid damage to the control panel and associated equipment. FACP operation and reliability depend upon proper installation.

Precau-D2-11-2017

FCC Warning

WARNING: This equipment generates, uses, and can radiate radio frequency energy and if not installed and used in accordance with the instruction manual may cause interference to radio communications. It has been tested and found to comply with the limits for Class A computing devices pursuant to Subpart B of Part 15 of FCC Rules, which is designed to provide reasonable protection against such interference when devices are operated in a commercial environment. Operation of this equipment in a residential area is likely to cause interference, in which case the user will be required to correct the interference at his or her own expense.

Canadian Requirements

This digital apparatus does not exceed the Class A limits for radiation noise emissions from digital apparatus set out in the Radio Interference Regulations of the Canadian Department of Communications.

Le présent appareil numérique n'émet pas de bruits radioélectriques dépassant les limites applicables aux appareils numériques de la classe A prescrites dans le Règlement sur le brouillage radioélectrique édicté par le ministère des Communications du Canada.

HARSH™, NIS™, and NOTI-FIRE-NET™ are all trademarks; and Acclimate® Plus™, eVance®, FlashScan®, FFAST Fire Alarm Aspiration Sensing Technology®, Honeywell®, Intelligent FFAST®, NOTIFIER®, ONYX®, ONYXWorks®, SWIFT®, VeriFire®, and VIEW® are all registered trademarks of Honeywell International Inc. Microsoft® and Windows® are registered trademarks of the Microsoft Corporation. Chrome™ and Google™ are trademarks of Google Inc. Firefox® is a registered trademark of The Mozilla Foundation.

©Monday, February 08, 2021 by Honeywell International Inc. All rights reserved. Unauthorized use of this document is strictly prohibited.

Software Downloads

In order to supply the latest features and functionality in fire alarm and life safety technology to our customers, we make frequent upgrades to the embedded software in our products. To ensure that you are installing and programming the latest features, we strongly recommend that you download the most current version of software for each product prior to commissioning any system. Contact Technical Support with any questions about software and the appropriate version for a specific application.

Documentation Feedback

Your feedback helps us keep our documentation up-to-date and accurate. If you have any comments or suggestions about our online Help or printed manuals, you can email us.

Please include the following information:

- Product name and version number (if applicable)
- Printed manual or online Help
- Topic Title (for online Help)
- Page number (for printed manual)
- Brief description of content you think should be improved or corrected
- Your suggestion for how to correct/improve documentation

Send email messages to:

FireSystems.TechPubs@honeywell.com

Please note this email address is for documentation feedback only. If you have any technical issues, please contact Technical Services.

Table of Contents

| | |
|--|-----------|
| Section 1: Using This Manual | 6 |
| 1.1: UL 864 9th Edition Compliance | 6 |
| 1.2: Related Documentation | 6 |
| Section 2: Network Nodes & Features | 7 |
| 2.1: Network Description..... | 7 |
| 2.2: Network Node Features | 7 |
| 2.3: UL 8th Edition Only | 10 |
| 2.4: Network Interface Boards | 11 |
| 2.5: Network Version Upgrades..... | 12 |
| Section 3: Network Configurations | 13 |
| 3.1: NFPA Class B Configurations | 13 |
| 3.2: NFPA Class X Configurations | 14 |
| 3.3: Configuration Definitions | 15 |
| 3.3.1: Point-to-Point Configuration | 15 |
| 3.3.2: Bus Configuration..... | 15 |
| 3.4: Terminating Point-to-Point and Bus Configurations | 16 |
| 3.5: Network Wiring for Ground Fault Detection..... | 17 |
| 3.6: Point-to-Point Configuration | 19 |
| 3.7: Bus Configuration..... | 20 |
| Section 4: Network Wiring Requirements | 22 |
| 4.1: Limit on Circuit Segment Length | 22 |
| 4.1.1: Limit for Twisted Pair Circuits..... | 22 |
| 4.1.2: Limit for Fiber Optic Circuits..... | 28 |
| 4.2: Limit on System Path Length | 28 |
| Appendix A: FCC Considerations | 30 |

Section 1: Using This Manual

This manual provides a system design overview for **NOTI•FIRE•NET™** version 5.0 and higher. It describes compatible fire alarm devices that can be linked to the network; network requirements and limitations; and configuration details, including those for NFPA Class B and Class X.



CAUTION: SOFTWARE VERSION
ALL EQUIPMENT ON THE NETWORK MUST BE RUNNING THE SAME VERSION OF THE NETWORK SOFTWARE.

For **NOTI•FIRE•NET™** networks prior to version 4.0, refer to manual 50257. Refer to section Section 2.3 on page 10 for version 4.0 information.

1.1 UL 864 9th Edition Compliance

NOTI•FIRE•NET™ Version 5.0 and higher works with products that have been certified to comply with the requirements in the Standard for Control Units and Accessories for Fire Alarm Systems, UL 864 9th Edition, as well as products that have not received UL 864 9th Edition certification. “UL 8th Edition Only” in Section 2.3 describes the equipment that can comprise a UL 8th Edition compliant network. Operation of a UL 864 9th Edition compliant network together with products not tested for UL 864 9th Edition has not been evaluated. Such operation requires the approval of the local Authority Having Jurisdiction (AHJ).

UL 864 9th and 10th Edition

- Per the UL Continuing Certification Program, UL 864 9th edition fire alarm control equipment will retain certification after the rollout of UL 10th edition (12/2/2018).
- Installations of UL 864 10th Edition certified equipment are permitted to use UL864 9th Edition certified equipment when approved by the local Authority Having Jurisdiction (AHJ).
- For product compliance, refer to the UL/ULC listing cards located on the UL online certification directory.

<https://iq.ulprospector.com/en/>

1.2 Related Documentation

This table lists equipment that connects directly to **NOTI•FIRE•NET™**; for information about connecting non-network devices to these network nodes, refer to the installation manual(s) for your system. To obtain a complete understanding of specific features within the network, or to become familiar with the network functions in general, make use of the documentation listed in Table 1.1. The Notifier Document chart (DOC-NOT) provides the current document revision. A copy of this document is included with each shipment of NOTIFIER® products.

| For information on... | Refer to... | Part No. |
|-------------------------------------|---|---------------------|
| Panels and Intelligent Annunciators | AFP-200 Fire Alarm Control Panel | 15511 |
| | AFP-300/AFP-400 Fire Alarm Control Panel | 50253, 50259, 50260 |
| | AM2020/AFP-1010 Fire Alarm Control Panel | 15088 |
| | Canadian Requirements for the AM2020/AFP-1010 | 15631 |
| | DVC/DVC-EM Digital Voice Command | 52411 |
| | NCA Network Control Annunciator | 51482 |
| | NCA-2 Network Control Annunciator | 52482 |
| | NCD Network Control Display | LS10210-051NF-E |
| | NCS Network Control Station, ONYX™ Network Version 5.0 and Higher | 51658 |
| | ONYXWorks Workstation | 52305, 52306, 52307 |
| | NFS-640 Fire Alarm Control Panel | 51332, 51333, 51334 |
| | NFS2-3030 Fire Alarm Control Panel | 52544, 52545, 52546 |
| | NFS-3030 Fire Alarm Control Panel | 51330, 51344, 51345 |
| | NFS2-640 Fire Alarm Control Panel | 52741, 52742, 52743 |
| NFS-320 Fire Alarm Control Panel | 52745, 52746, 52747 | |
| N16 Fire Alarm Control Panel | LS10239-051NF-E | |
| Network Interface Equipment | MIB Media Interface Board | 50255 |
| | NAM-232 Network Adaptor Module | 50038 |
| | NCM-W/F Installation Document | 51533 |
| | RPT Repeater | 50256 |
| | CLSS Gateway | LS10248-000HW-E |
| Off-line Programming Utility | VeriFire Tools help file | VeriFire-TCD |
| Compatible Devices | Device Compatibility Document | 15378 |

Table 1.1 Network Related Documentation

Section 2: Network Nodes & Features

2.1 Network Description

NOTI•FIRE•NET™ is a series of modules and products which allow a group of Fire Alarm Control Panels (FACPs) and other control equipment to connect, forming a true peer-to-peer network. Equipment that connects to **NOTI•FIRE•NET™** and communicates with other equipment using the network may be referred to as a network node. The minimum hardware requirement for **NOTI•FIRE•NET™** is two nodes connected via wire or fiber optic cable. **NOTI•FIRE•NET™** supports up to 103 nodes with a maximum capacity of 201,960 points. It will support up to 54 nodes when it is set up to circulate live paging from a DVC node. Each network node requires a unique node address; the node communicates with other nodes via a network interface board. This section provides network-level requirements for these devices; refer to the specific manuals for details on requirements for individual components such as FACPs. See “Network Node Features” in Section 2.2 for a discussion of network nodes and “Network Interface Boards” in Section 2.4 for a discussion of interface boards.

NOTI•FIRE•NET™ requires its FACP nodes use addressable initiating devices or connect non-addressable initiating devices to the device through addressable modules. Compatible devices include initiating & control modules, manual pull stations, and intelligent detectors; refer to the control panel installation manuals listed in Table 1.1 for model numbers.

The network supports communications over twisted pair wire and fiber optic media, through a proprietary communications protocol. Both wire and fiber may exist in the same network when routed through MIB-WF or RPT-WF.

When properly configured, **NOTI•FIRE•NET™** is suitable for use as a Protected Premises Fire Alarm System as defined in the National Fire Protection Association (NFPA) 72 documentation.

2.2 Network Node Features

On each fire alarm control panel or intelligent annunciator, a network interface board (*listed below in italics*) provides the physical connection; see “Network Interface Boards” in Section 2.4.

Note: All boards must be running the same version of **NOTI•FIRE•NET™**; equipment running earlier versions can be upgraded as described in “Network Version Upgrades” on page 12 (see label on chip for version number).

■ **DVC/DVC-EM.** *With NCM-W or NCM-F*

The DVC/DVC-EM (DVC) occupies a single node address on the network. NCM cables plug into the two DVC NUP ports. Cooperative Control-by-Event programming enables the DVC to react to events on other network nodes.

The minimum requirements for a DVC node are a DVC, a power supply (an ONYX panel or local power supply), and a network communications module NCM-W/F running network version 5.0 or higher.

■ **NCA-2.** *With NCM-W or NCM-F*

The NCA-2 Network Control Annunciator provides a text-based display and control device for the **NOTI•FIRE•NET™** system. The NCM enables the NCA-2 to display all events from FACPs on the **NOTI•FIRE•NET™** system. It can co-exist with other NCA-2s, or it can be the sole interface on the network; it can be used to display the network in desirable groups of nodes. The NCA-2 also supports the use of optional devices such as annunciators and printers. The NCA-2 is capable of interfacing with the NFS2-3030¹, ONYXWorks, NFS-320, NFS2-640, NFS-640¹, NCA¹, N16 and the DVC/DVC-EM.

NCA-2 requires cabinet mounting, a network communications module NCM-W or NCM-F running the same version of **NOTI•FIRE•NET™** as the rest of the network (**NOTI•FIRE•NET™** 5.0 or higher), and a +24 VDC filtered power source. This power can come from the control panel or from a remote power supply.

■ **NCD.** *With NCM-W or NCM-F*

The NCD Network Control Display provides a text-based display and control device for the **NOTI•FIRE•NET™** system. The NCM enables the NCD to display all events from FACPs on the **NOTI•FIRE•NET™** system. It can be used to display the network in desirable groups of nodes. The NCD is capable of interfacing with the NFS2-3030¹, ONYXWorks, NFS-320, N16, and NFS2-640.

NCD requires cabinet mounting, a network communications module NCM-W or NCM-F running the same version of **NOTI•FIRE•NET™** as the rest of the network (**NOTI•FIRE•NET™** 5.0 or higher), and a +24 VDC filtered power source. This power can come from the control panel or from a remote power supply.

■ **VESDA®.** *With VESDA Gateway, HLI, and NCM-W or NCM-F*

The VESDA Early Warning Aspiration System provides fire detection through the use of air sampling. The NCM, VESDA Gateway and HLI (High Level Interface) enable the VESDA system to connect to the **NOTI•FIRE•NET™**. The VESDA node occupies a single node on the network. If events or troubles are detected, the VESDA system will communicate the condition over the network to be displayed on network reporting nodes such as the NCA-2.

NOTE: An NCA-2 Network Control Annunciator or the ONYXWorks-WS is required when a VESDA-HLI-GW is installed.

1. Not UL 9th Edition compliant

■ **Network Control Station (NCS 5.0 or higher).** Available as NCS-W-ONYX or NCS-F-ONYX; compatible with NCS-W or NCS-F.

The NCS provides a PC-based graphical interface for monitoring and controlling activity of multiple nodes on a network. It allows the user to program network nodes, display network information, and display the network in desirable groups of nodes. It can perform resets, signal silence, and acknowledge on sets of nodes. It also contains a history buffer which can record events and actions which have occurred in the network.

NCS is a personal computer (UL listed for fire control applications) with interface board installed and with specific software provided. **Do not install third-party software such as office applications or games on this PC.** See your NCS Manual for operating requirements.

| NCS Version | Compatible Noti•Fire•Net™ Version | Models |
|---------------|-----------------------------------|--|
| NCS version 5 | NOTI•FIRE•NET™ 5.0 | NCS5-W-ONYX with NCS computer P/N NCS5-P4F NCS5-F-ONYX with NCS computer P/N NCS5-P4W |

Table 2.1 NCS/Network Version Compatibility

NCS version number is found on the CD label, and under the NCS Help menu: About NCS; see “Network Version Upgrades” in Section 2.5.

■ **ONYXWorks™ Workstation** See Table 2.2 for Compatibilities

This workstation provides a PC-based graphical interface for monitoring and controlling activity of multiple nodes on a network. It allows the user to program network nodes, display network information, and display the network in desirable groups of nodes. It can perform resets, signal silence, and acknowledge on sets of nodes. It also contains a history buffer which can record events and actions which have occurred in the network.

The ONYXWorks™ workstation is a personal computer (UL listed for fire control applications) with interface board installed and with specific software provided. **Do not install third-party software such as office applications or games on this PC.** See your ONYX-Works™ Workstation manual for operating requirements.

| Compatible Noti•Fire•Net™ Version | Models | Card Compatibility |
|-----------------------------------|--------------|---|
| NOTI•FIRE•NET™ 5.0 | ONYXWORKS | Embedded Gateway NFN-GW-EM with NCM-W/F |
| NOTI•FIRE•NET™ 5.0 | ONYXWORKS-NW | PC-based Gateway NFN-GW-PC-W |
| NOTI•FIRE•NET™ 5.0 | ONYXWORKS-NF | PC-based Gateway NFN-GW-PC-F |
| NOTI•FIRE•NET™ 5.0 | ONYXWORKS-EW | NION-NFN with NCM-W/F |

Table 2.2 ONYXWorks™/Network Version and Card Compatibility

■ **NFS2-3030.** With NCM-W or NCM-F

The NFS2-3030 occupies a single node address on the network. The NCM cable plugs into the CPU2-3030D/ND. The network has the ability to send acknowledge, signal silence, drill, and system reset commands to the NFS2-3030. Cooperative Control-by-Event programming enables the panel to react to or trigger events on other network nodes.

The minimum requirements for an NFS2-3030 node are the central processing unit (CPU2-3030D or CPU2-3030ND), AMPS-24/E main power supply, LCM-320, a cabinet, and a network communications module NCM-W or NCM-F running network version 5.0 or higher.

NOTE: Choose the CPU2-3030ND version of NFS2-3030’s CPU only when the unit is to be entirely controlled by another node on **NOTI•FIRE•NET™** (such as NCS); programming requires VeriFire Tools™.

■ **N16E/N16X.** With NCM-W or NCM-F

The N16E/N16X occupies a single node address on the network. The NCM cable plugs into the CPU2-N16ND. The network has the ability to send acknowledge, signal silence, drill, and system reset commands to the N16E/N16X. Cooperative Control-by-Event programming enables the panel to react to or trigger events on other network nodes.

The minimum requirements for an N16E/N16X node is a CPU-N16LD, CPU-N16LND, or an N16e, a cabinet, and a network communications module NCM-W or NCM-F running network version 5.0 or higher.

■ **NFS2-640.** With NCM-W or NCM-F

The NFS2-640 occupies a single node address on the network. The NCM cable plugs into the main circuit board of the NFS2-640. The network has the ability to send acknowledge, signal silence, drill, and reset commands to the NFS2-640. Cooperative Control-by-Event programming enables the panel to react to or trigger events on other network nodes.

The minimum requirements for an NFS2-640 node are the basic equipment package (includes CPU board with integral power supply), a cabinet, and a network connection module NCM-W or NCM-F running the same version of **NOTI•FIRE•NET™** as the rest of the network (version 4.0 or higher). NFS2-640 also requires a primary display be installed if it is not to be entirely controlled and programmed by another node on **NOTI•FIRE•NET™** (such as ONYXWorks).

■ NFS-320. *With NCM-W or NCM-F*

The NFS-320 occupies a single node address on the network. The NCM cable plugs into the main circuit board of the NFS-320. The network has the ability to send acknowledge, signal silence, drill, and reset commands to the NFS-320. Cooperative Control-by-Event programming enables the panel to react to or trigger events on other network nodes.

The minimum requirements for an NFS-320 node are the basic equipment package (includes CPU board and keypad mounted in cabinet with integral power supply), and a network connection module NCM-W or NCM-F running the same version of **NOTI•FIRE•NET™** as the rest of the network (version 4.0 or higher).

2.3 UL 8th Edition Only

■ AFP-200, AFP-300, AFP-400. *With NAM-232W/F*

The NAM-232 connects to the AFP-200 or AFP-300/400 through the EIA-232 serial communications port. The network has the ability to send acknowledge, signal silence, drill, and reset commands to the AFP-200 or AFP-300/400. Cooperative Control-by-Event programming enables the panel to react to or trigger events on other network nodes.

Note for AFP-200 only: Use of the NAM-232 prevents use of a printer or CRT at the panel.

Note for AFP-300/400 only: Use of NAM-232 limits the functions of CRT-2 to display only; it cannot control the panel.

The minimum requirements for an AFP-200, AFP-300, or AFP-400 node are the FACP's CPU board with power supply, cabinet, and a NAM-232W or NAM-232F running the same version of **NOTI•FIRE•NET™** as the rest of the network (4.0 or higher). See "Network Version Upgrades" in Section 2.5.

■ AM2020, AFP-1010. *With SIB-NET and MIB-W/F/WF*

The AM2020/AFP-1010 collects information about modules and peripherals connected to the network and makes this information accessible to all nodes connected to the network. Information from the panel may include the following signals: fire alarm, security alarm, trouble, and supervisory. Cooperative Control-by-Event programming enables the panel to react to or trigger events on other network nodes.

The minimum requirements for an AM2020/AFP-1010 node are the basic equipment package for network use (BE-2020N/1010N), loop interface board (LIB-200, LIB-200A, or LIB-400), power supply, cabinet, and SIB-NET with MIB-W/F/WF running the same version of **NOTI•FIRE•NET™** as the rest of the network (network version 4.0 or higher). See "Network Version Upgrades" in Section 2.5.

The basic equipment package includes CPU and display assembly (DIA). Refer to AM2020/AFP-1010 documentation for a more detailed account of these applications:

- Additional requirement for NFPA 72 Local Fire Alarm Systems Applications: A control module is installed on Signal Loop Circuit (SLC) 1 in every AM2020/AFP-1010 network and set to module address 96. Refer to AM2020/AFP-1010 documentation for a more detailed account of this installation.
- Additional requirement for NFPA 72 Central Station and Proprietary Fire Alarm Systems Protected Premises Units Applications: A non-networked AM2020/AFP-1010 receiving unit communicates with a network node via a NIB-96 network interface board.

■ NFS-3030. *With NCM-W or NCM-F*

The NFS-3030 occupies a single node address on the network. The NCM cable plugs into the CPU-3030. The network has the ability to send acknowledge, signal silence, drill, and system reset commands to the NFS-3030. Cooperative Control-by-Event programming enables the panel to react to or trigger events on other network nodes.

The minimum requirements for an NFS-3030 node are the central processing unit (CPU-3030D or CPU-3030ND), AMPS-24/E main power supply, LCM-320, a cabinet, and a network connection module NCM-W or NCM-F running network version 5.0 or higher.

NOTE: Choose the CPU-3030ND version of NFS-3030's CPU only when the unit is to be entirely controlled by another node on **NOTI•FIRE•NET™** (such as ONYXWorks); programming requires VeriFire™.

■ NFS-640. *With NCM-W or NCM-F*

The NFS-640 occupies a single node address on the network. The NCM cable plugs into the main circuit board of the NFS-640. The network has the ability to send acknowledge, signal silence, drill, and reset commands to the NFS-640. Cooperative Control-by-Event programming enables the panel to react to or trigger events on other network nodes.

The minimum requirements for an NFS-640 node are the basic equipment package (includes CPU board with integral power supply), a cabinet, and a network connection module NCM-W or NCM-F running the same version of **NOTI•FIRE•NET™** as the rest of the network (version 4.0 or higher). NFS-640 also requires a primary display be installed if it is not to be entirely controlled and programmed by another node on **NOTI•FIRE•NET™** (such as ONYXWorks). See "Network Version Upgrades" in Section 2.5.

■ Network Control Annunciator (NCA) *With NCM-W or NCM-F*

The Network Control Annunciator provides a text-based display and control device for the **NOTI•FIRE•NET™** system. The NCM enables the NCA to display all events from FACP's on the **NOTI•FIRE•NET™** system. It can co-exist with other NCAs, or it can be the sole interface on the network; it can be used to break the network into desirable groups of nodes. The NCA also supports the use of optional devices such as annunciators, printers and CRTs. The NCA is capable of interfacing with the NFS-3030, NFS-640, and legacy panels such as the AFP-200, AFP-300/AFP-400 and AM2020/AFP-1010.

NCA requires cabinet mounting, a network connection module NCM-W or NCM-F running the same version of **NOTI•FIRE•NET™** as the rest of the network (**NOTI•FIRE•NET™** 4.0 or higher), and a +24 VDC filtered power source. This power can come from the control panel or from a remote power supply. If local ground-fault detection is required, an MPS-24 series power supply must be used. See "Network Version Upgrades" in Section 2.5.

■ Network Control Station (NCS 2.0 or higher)

Available as NCS-W-ONYX or NCS-F-ONYX; compatible with NCS-W or NCS-F.

The NCS provides a PC-based graphical interface for monitoring and controlling activity of multiple nodes on a network. It allows the user to program network nodes, display network information, and break the network into desirable groups of nodes. It can perform resets, signal silence, and acknowledge on sets of nodes. It also contains a history buffer which can record events and actions which have occurred in the network.

NCS is a personal computer (UL listed for fire control applications) with interface board installed and with specific software provided. **Do not install third-party software such as office applications or games on this PC.** See your NCS Manual for operating requirements.

| NCS Version | Compatible Noti•Fire•Net™ Version | Models |
|---------------|-----------------------------------|---|
| NCS version 1 | NOTI•FIRE•NET™ 3.0 | NCS-M17W, NCS-M17F, NCS-M17WF, NCS-M19W, NCS-M19F, NCS-M19WF, NCS-M21F, NCS-M21W, NCS-M21WF |
| NCS version 2 | NOTI•FIRE•NET™ 4.0 | NCS-W-ONYX, NCS-F-ONYX, NCS-W, NCS-F |
| NCS version 3 | NOTI•FIRE•NET™ 5.0 | NCS3-W-ONYX, NCS3-F-ONYX |
| NCS version 4 | NOTI•FIRE•NET™ 5.0 | NCS4-W-ONYX, NCS4-F-ONYX |

Table 2.3 NCS/Network Version Compatibility

NOTE: NCS version number is found on the CD label, and under the NCS Help menu: About NCS; see “Network Version Upgrades” in Section 2.5.

2.4 Network Interface Boards

This section discusses the boards that are physically connected together to form the network. “Network Node Features” in Section 2.2 specifies the **NOTI•FIRE•NET™** version compatible with each node/board combination.

■ NAM-232W, NAM-232F

The NAM-232 provides a physical communication interface between the AFP-200 or AFP-300/AFP-400 to the wire or fiber-optic cable which connects the node to another node on the network. Each NAM-232 has two communication ports, in two possible media combinations:

- NAM-232W: Two twisted pair wire ports.
- NAM-232F: Two fiber optic cable ports.

NAM-232W or NAM-232F must be running the same version of **NOTI•FIRE•NET™** as the rest of the network (version 4.0 or higher). See “Network Version Upgrades” in Section 2.5.

■ NCM-W, NCM-F

The Network Communications Module (NCM) provides a physical communication interface between the NFS2-3030, NFS-3030, NFS2-640, NFS-640, NFS-320, NCA-2, NCA or NCD and the wire or fiber-optic cable which connects the node to another node on the network. Each NCM has two communication ports, in two possible media combinations:

- NCM-W: Two twisted pair wire ports.
- NCM-F: Two fiber optic cable ports.

NCM-W or NCM-F must be running the same version of **NOTI•FIRE•NET™** as the rest of the network (version 4.0 or higher). See “Network Version Upgrades” in Section 2.5.

■ NCS-NCW, NCS-NCF

NCS-NCW and NCS-NCF are component boards; NCS ships with one of these internal boards already installed. They are included here because they perform a similar function to other boards listed in this section. These boards provide a physical communication interface between the NCS and the wire or fiber-optic cable which connects the node to another node on the network. Each board has two communication ports, in two possible media combinations:

- NCS-NCW: Two twisted pair wire ports. (Part of NCS-W-ONYX, NCS3-W-ONYX, NCS4-W-ONYX, NCS5-W-ONYX and NCS-W)
- NCS-NCF: Two fiber optic cable ports. (Part of NCS-F-ONYX, NCS3-F-ONYX, NCS4-F-ONYX, NCS5-W-ONYX and NCS-F)

NOTE: Note: NCS versions prior to 2.0 are not supported on **NOTI•FIRE•NET™** version 4.0. NCS versions prior to 3.0 are not supported on **NOTI•FIRE•NET™** version 5.0 or higher. NCS version number is found on the CD label, and under the NCS Help menu: About NCS. See “Network Version Upgrades” in Section 2.5.

■ NFN-GW-PC-W, NFN-GW-PC-F

These boards provide a physical communication interface between the ONYXWorks Workstation and the wire or fiber-optic cable which connects the node to another node on the network. Each board has two communication ports, in two possible media combinations:

- NFN-GW-PC-W: Two twisted pair wire ports.

- NFN-GW-PC-F: Two fiber optic cable ports.

■ RPT-W, RPT-F, RPT-WF

The Repeaters (RPT) boost data signals between network nodes extending communication distances. RPT-WF can be used to pass data transmissions between two differently configured network segments when wire and fiber-optic cable co-exist on the network. Each RPT has two communication ports, in three possible media combinations:

- RPT-W: Two twisted pair wire ports.
- RPT-F: Two fiber optic cable ports.
- RPT-WF: One twisted pair wire port and one fiber optic cable port.

■ SIB-NET with MIB-W, MIB-F, or MIB-WF

The Serial Interface Board for **NOTI•FIRE•NET™** (SIB-NET) works with the Media Interface Board (MIB) to provide a physical communication interface between the AM2020/AFP-1010 and the wire or fiber-optic cable which connects the node to another node on the network. This configuration supports annunciators, printers, and CRTs. Each MIB has two communication ports, in three possible media combinations:

- MIB-W: Two twisted pair wire ports.
- MIB-F: Two fiber optic cable ports.
- MIB-WF: One twisted pair wire port and one fiber optic cable port.

SIB-NET must be running the same version of **NOTI•FIRE•NET™** as the rest of the network (Network version 4.0 or higher); see “Network Version Upgrades” in Section 2.5.

2.5 Network Version Upgrades

- **NAM Upgrade Kit**
Network 3.0 to 4.0: NROM-NAM4.0M
Network 3.0/4.0 to 5.0: NROM-NAM5.0M
- **NCA Software upgrade**
Network 4.0 to 5.0: No kit required: Web-upgrade to NCA-2.0.x (or higher)
- **NCM Upgrade**
Network 4.0 to 5.0: No kit required: Web-upgrade to NCM-2.0.x (or higher)
- **NCS Upgrade from NCS version 1 to NCS version 2 (for Network 4.0)**
Software: NCSCDUG-US-2
Cards: NCSKIT-NCW, NCSKIT-NCF
- **NCS Upgrade from NCS version 1 to NCS version 3/4/5 (for Network 5.0)**
Software: NCSCDUG-US-3, NCSCDUG-US-4 or NCSCDUG-US-5
Cards: NCSKIT-NCW, NCSKIT-NCF
- **NCS Upgrade from NCS version 2/3/4 to NCS version 3/4/5 (for Network 5.0)**
Software: NCSCDUG-US-3, NCSCDUG-US-4 or NCSCDUG-US-5.
Cards: n/a
- **NFS-640 Software Upgrade**
Network 4.0 to 5.0: No kit required: Web-upgrade to 640-2.0.x.
- **SIB-NET Software upgrade kits**
Network 3.0 to 4.0: AROM4.0M-SIB
Network 3.0/4.0 to 5.0: AROM5.0M-SIB

Section 3: Network Configurations

3.1 NFPA Class B Configurations

NOTI•FIRE•NET™ is capable of communicating using an NFPA Class B SLC (refer to Figure 3.1). Under this Class of operation, a single open, wire-to-wire short, wire-to-wire short and open, wire-to-wire short and ground, or open and ground results in fragmentation of the network. A single ground does not affect communication, but is detected. Each fragment of the network reconfigures to permit communication among the nodes within the fragment.

NFPA Class B SLC Without Regeneration:

A wire-to-wire short in this segment would result in loss of communication between all four nodes/repeaters on this bus connection as well as fragmentation of the network. Bus connections should be no longer than 100 feet within conduit or located within the same enclosure.

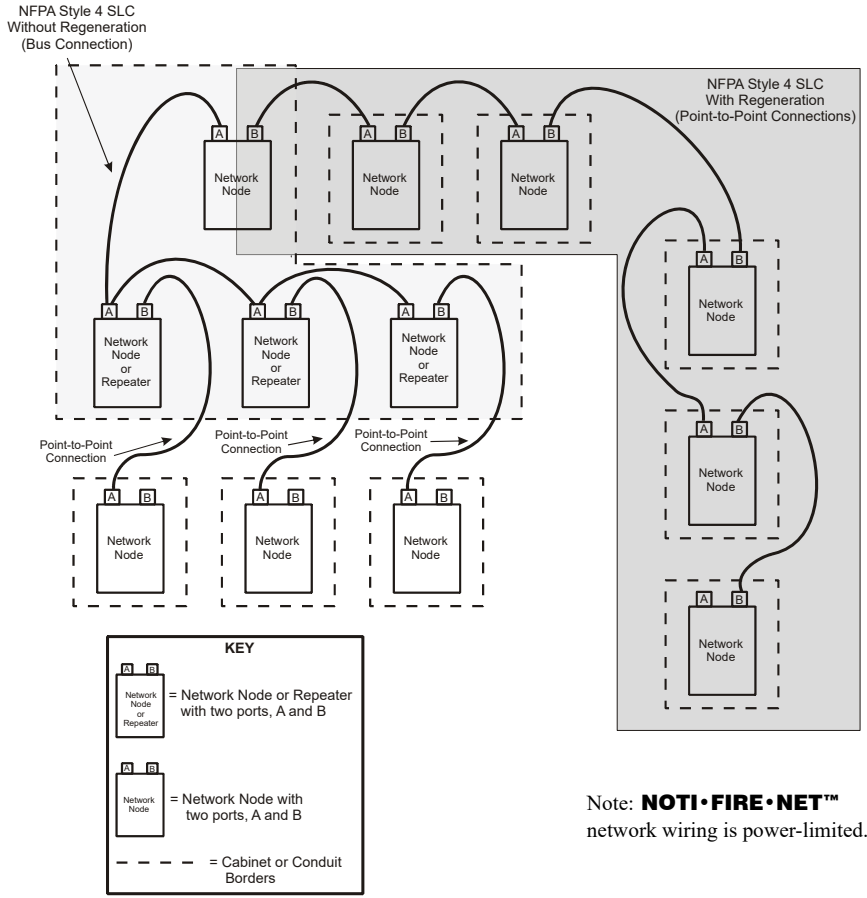

Note: **NOTI•FIRE•NET™** network wiring is power-limited.

Figure 3.1 Class B Configurations

In an NFPA Class B fiber-optic system, a single break will result in loss of communication between network nodes within the fragment of the network that can only receive signals from the other fragment (refer to Figure 3.2). In Figure 3.2, the fragment to the left of the break cannot receive information from the fragment to the right of the break. However, the fragment to the right of the break can receive information from the fragment to the left of the break.

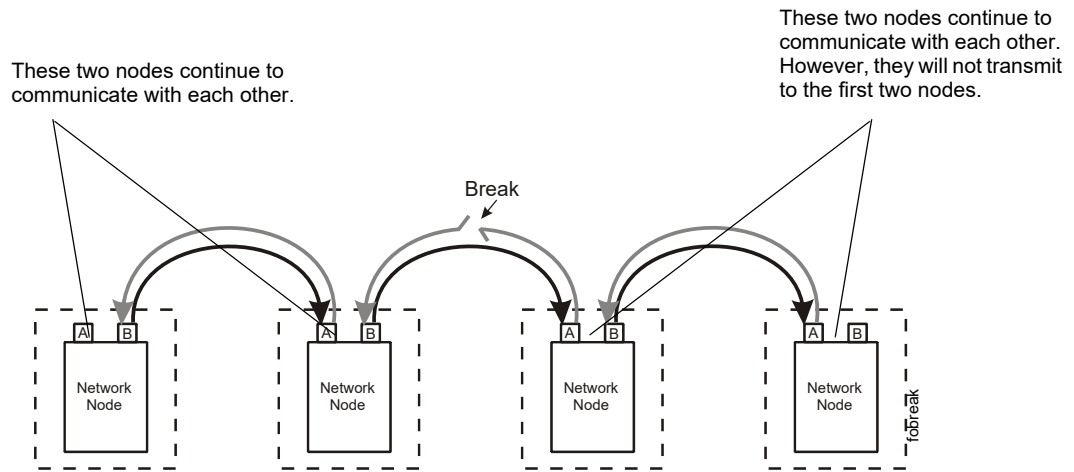

Figure 3.2 Fiber-Optic Class B System Break

3.2 NFPA Class X Configurations

NOTI•FIRE•NET™ is capable of communicating using an NFPA Class X SLC (refer to Figure 3.3). Under this Class of operation, a single open, wire-to-wire short, wire-to-wire short and open, wire-to-wire short and ground, or open and ground will not result in fragmentation of the network. Communication will continue throughout any of the aforementioned circumstances, while the system displays a trouble condition. A single ground does not affect communication, but is detected. Class X operation may also be achieved using fiber optic cable or mixed media (wire and fiber).

NOTE: Bus connections are not permitted in a Class X system.

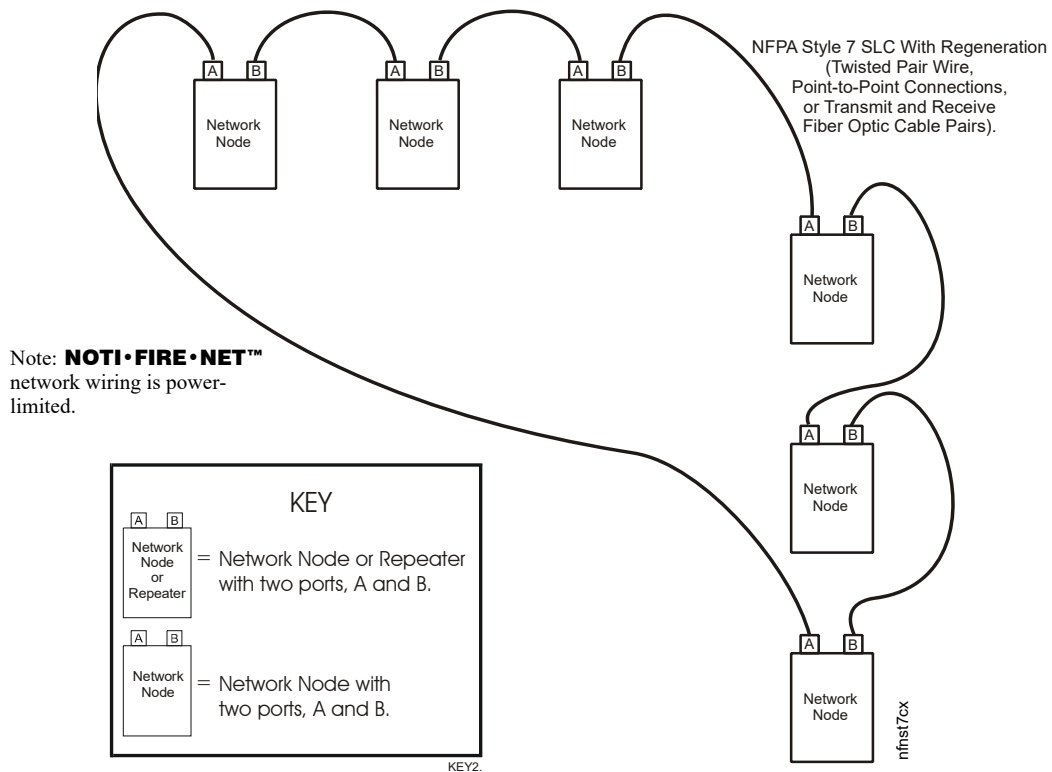

Figure 3.3 Class X Configurations

3.3 Configuration Definitions

3.3.1 Point-to-Point Configuration

A point-to-point wiring configuration is defined as a twisted-pair wire segment with only two nodes/repeaters attached to it. Terminating resistors are required at each end of every twisted-pair wire segment. They are built into each MIB-W, MIB-WF, NAM-232W, RPT-W, and RPT-WF; and they are a selectable option on the NCM-W, NCS-NCW, and NFN-GW-PC-W. Refer to “Terminating Point-to-Point and Bus Configurations” on page 16 for more information.

In a point-to-point configuration, two nodes/repeaters are interconnected by a single circuit that is terminated at each port (refer to Figure 3.4).

■ Characteristic Impedance in a Point-to-Point Configuration

The wire segment of each point-to-point connection is a transmission line. The physical construction of the twisted-pair cable used for a segment determines the characteristic impedance of that segment. To minimize unwanted data reflections, never mix more than one brand name, gauge, or type of wire within a point-to-point segment.

If a network employs point-to-point wiring only, a separate pair of wires must be run between each node/repeater port (refer to Figure 3.4).

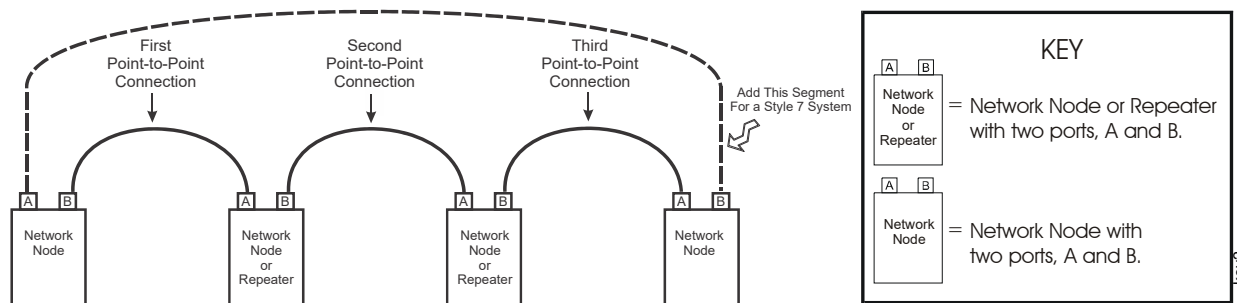

Figure 3.4 Point-to-Point Configuration for NFPA Class B or Class X

3.3.2 Bus Configuration

A bus wiring configuration is defined as a twisted pair network with more than two nodes. Terminating resistors are only needed for the first and last nodes of the bus configuration, all other terminating resistors must be removed.

In a bus configuration, more than one node/repeater shares the same circuit (refer to Figure 3.5).

A fault anywhere along the bus will affect the rest of the nodes/repeaters on the bus. Because of their inherent weakness, bus configurations are best employed for wiring between nodes/repeaters local to each other (within the same cabinet or room).

■ Wiring Distances Between Nodes On a Bus

In a bus configuration, data is shared between all ports on the twisted pair, thereby reducing the allowable transmission distance to a maximum of 100 feet (refer to Table 4.1).

■ Characteristic Impedance In a Bus Configuration

The wire segment of each bus connection is a transmission line. The physical construction of the twisted-pair cable used for a segment determines the characteristic impedance of that segment. To minimize unwanted data reflections, never mix more than one brand name, gauge, or type of wire within a bus segment. Always make bus connections at the module terminals provided. Do not make branch connections at other points.

A combination configuration can be used to distribute the network circuit from a central facility, saving on wiring run lengths. In Figure 3.6, a repeater was bus-wired to two existing nodes in each central facility (located within the same room) to support point-to-point connections to the remaining buildings in the system.

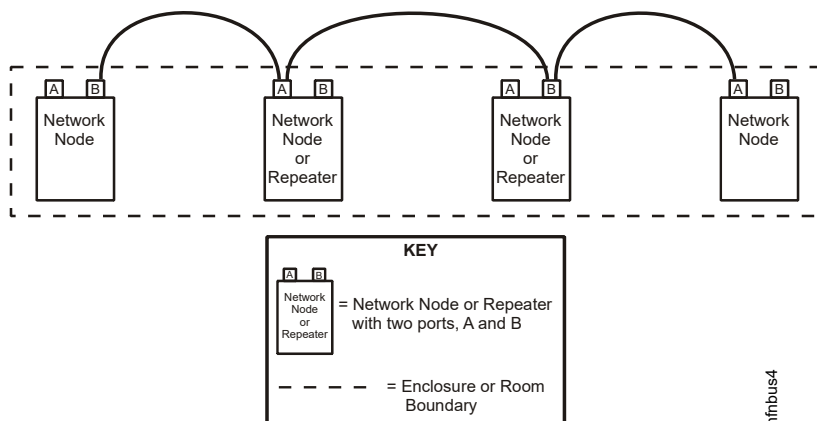

Figure 3.5 Bus Configuration (NFPA Class B Only)

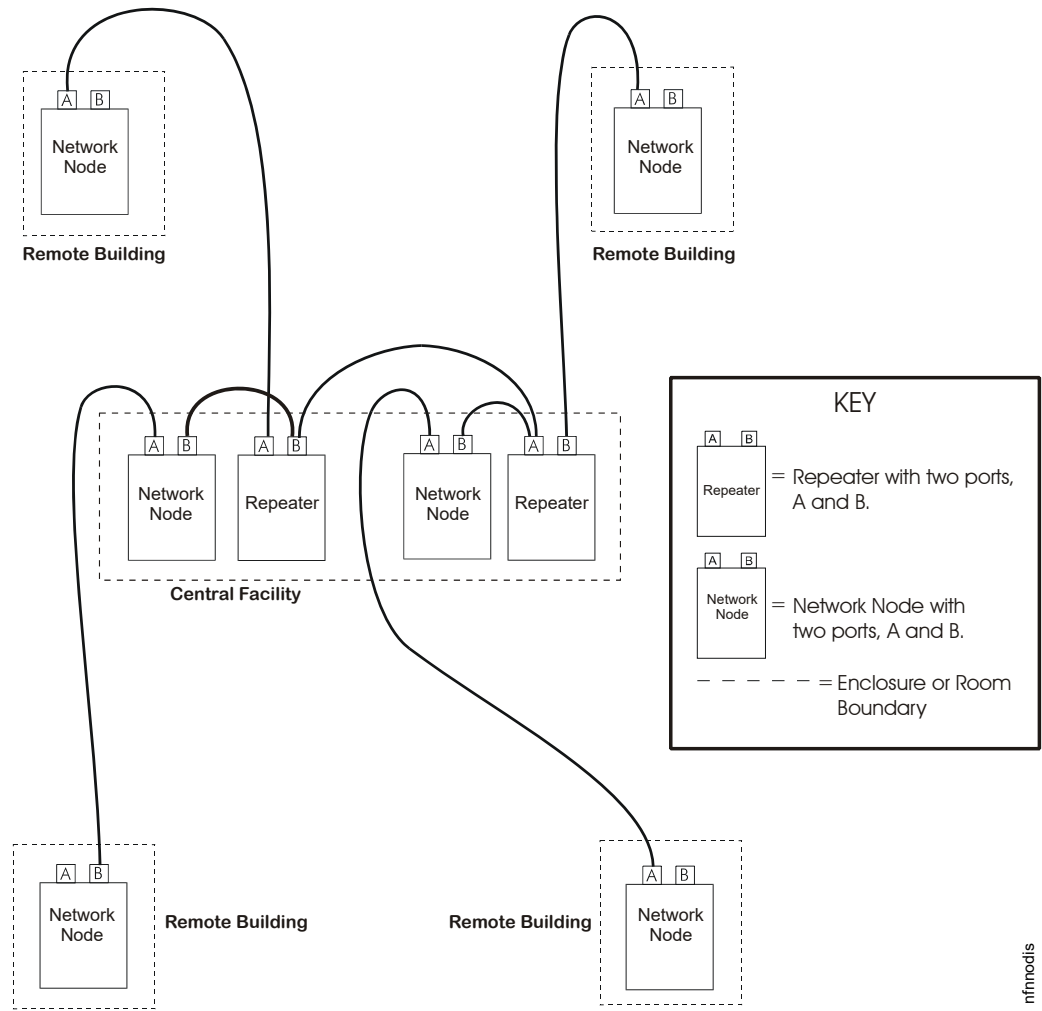

Figure 3.6 Combination Wiring

3.4 Terminating Point-to-Point and Bus Configurations

Both point-to-point and bus configurations require end-of-line resistor termination at each end of the respective circuit. Whereas a point-to-point circuit has a terminating resistor at each node/repeater port (refer to Figure 3.7), a bus circuit spans multiple nodes/repeaters, with termination only on the associated port of the first and last (end) nodes on the segment (refer to Figure 3.8).

Terminating Resistors

There must be a functioning terminating resistor on the first and last node/repeater of a wire segment. The terminating resistor must be disabled or removed for all other nodes/repeaters connected to the same bus segment. See Table 3.1.

Disable terminating resistors with a slide switch on the NCM-W, NCS-NCW (open NCS-W-ONYX or NCS-W to access this PC card) or NFN-GW-PC-W. Cut and remove the factory-installed terminating resistors for the MIB-W, MIB-WF, NAM-232W, RPT-W, and RPT-WF as shown in Figure 3.7 and Figure 3.8.

| | Port A | Port B |
|-------------|--------|--------|
| RPT-W | R40 | R41 |
| RPT-WF | R40 | |
| MIB-W | R20 | R21 |
| MIB-WF | R20 | |
| NAM-232W | R69 | R70 |
| NCM-W | SW100 | SW102 |
| NCS-NCW | SW100 | SW102 |
| NFN-GW-PC-W | SW100 | SW102 |

Table 3.1 On-Board Terminating Resistors

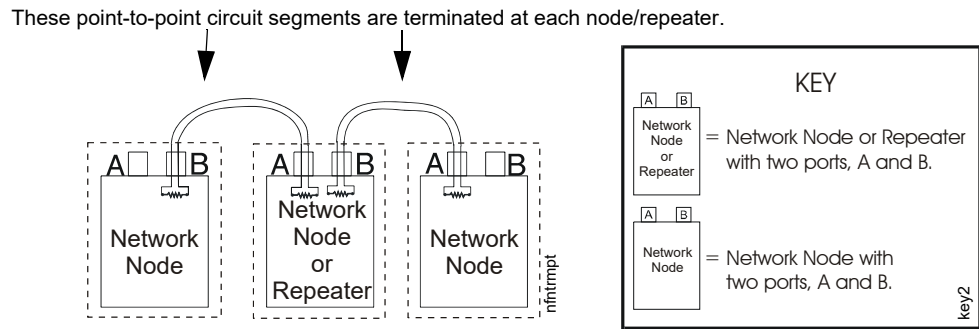

Figure 3.7 Point-to-Point Termination

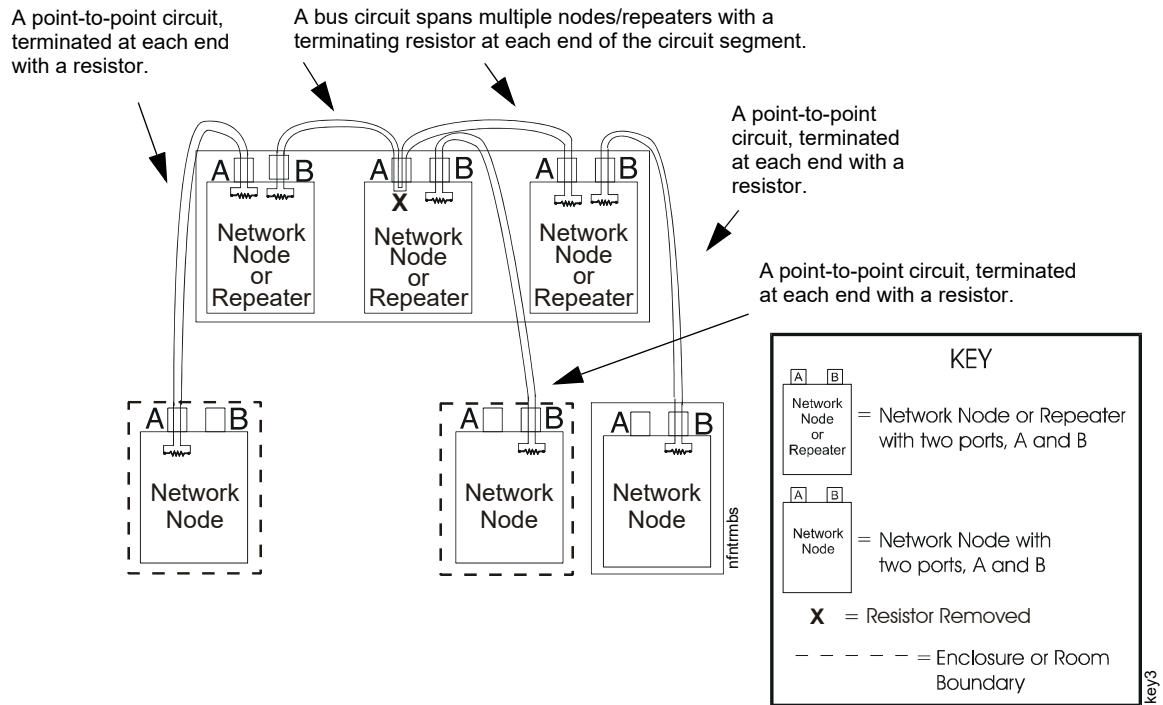

Figure 3.8 Bus Termination

3.5 Network Wiring for Ground Fault Detection

Because the twisted pair communication link between adjacent nodes can be isolated from the nodes through the NCM, MIB, or NAM-232 (transformer coupling), a single ground fault on one of the wires will have no effect on circuit operation. For this reason, ground fault detection for the isolated link is not necessary unless required by the Authority Having Jurisdiction.

Ground fault detection from a node power supply may be fed-through or disabled with switches on the MIB-W, MIB-WF, NAM-232W, RPT-W, NCM-W, NCS-W-ONYX and NCS-W. Set switch to ENABLE/ON as shown in Figure 3.9. In the examples that follow, the MIB-W is used as an example; refer to Figure 3.9 for equivalent switch orientation of other boards used in its place.

Ground fault detection may be provided by the following nodes:

- Fire alarm control panel node powered by a Main Power Supply (MPS-24A)
- NFS2-3030/NFS-3030 or NFS2-3030/NFS-3030 node powered by AMPS-24/E
- N16E/N16X (With PMB)
- NFS-640, NFS2-640, NFS-320 node (own power supply)
- AFP-200 node (own power supply)
- NCA node powered by Main Power Supply (MPS-24 series)
- NCA-2 node powered by AMPS-24/E
- AFP-300/AFP-400 with MPS-400

NOTE: NCS does not detect ground-fault, but NCS-W-ONYX and ONYXWORKS-NW can pass the signal between network nodes on either side of NCS. Disabling ground fault detection will prevent signal feed-through.

The following paragraphs highlight ground fault detection considerations for point-to-point and bus wire configurations.

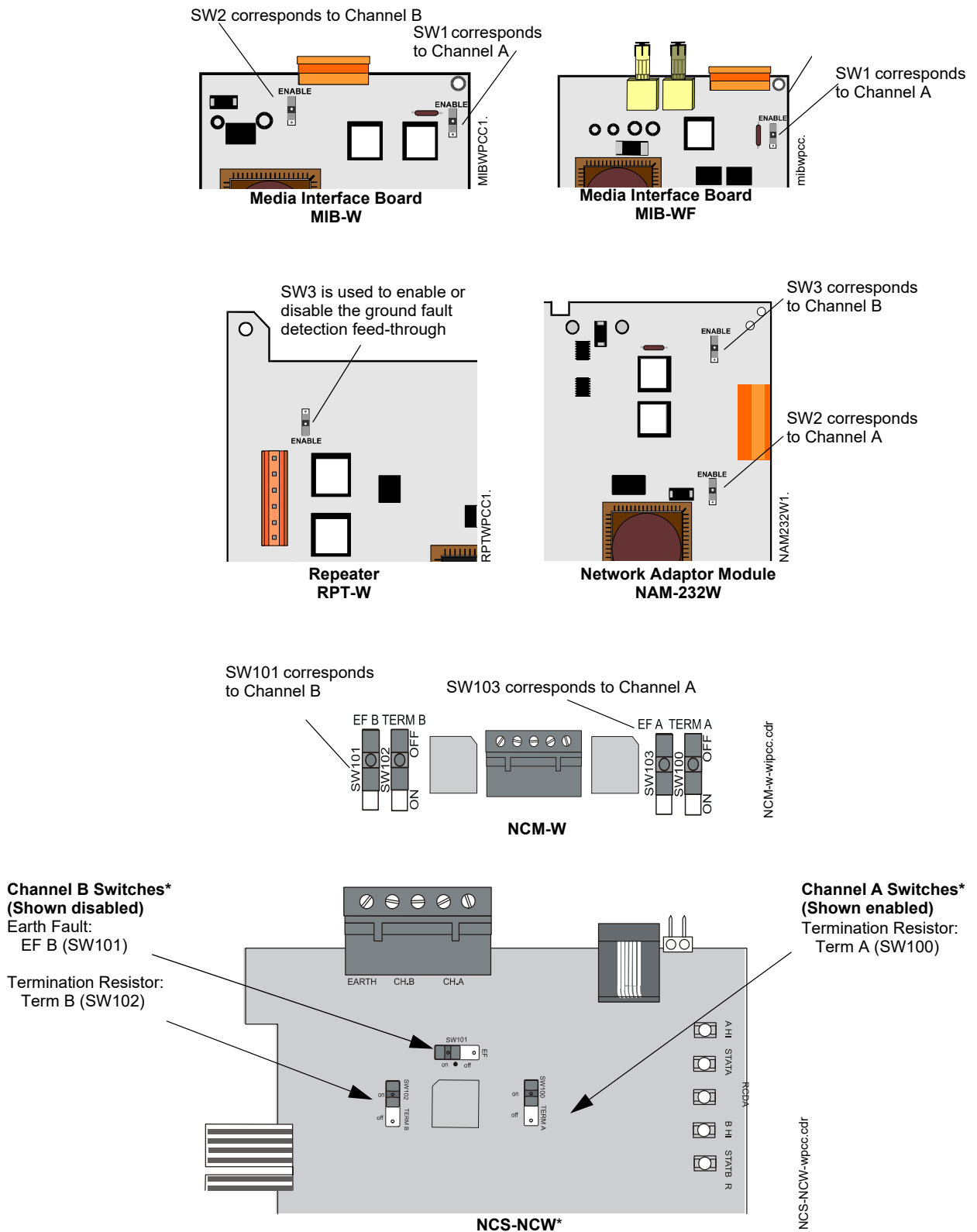

*Note: NCS does not detect ground-fault, but NCS-W-ONYX can pass the signal between network nodes on either side of NCS. Disabling ground fault detection will prevent signal feed-through.

Figure 3.9 Ground Fault Switches

3.6 Point-to-Point Configuration

In a point-to-point configuration without repeaters, enable ground fault detection in only one of the two nodes. In Figure 3.10, the left node provides the ground fault detection, and thus must be one of the ground-fault detection nodes defined on page 17. SW2 is set to the ON position to enable ground fault detection on Port B. The corresponding Port A switch of the right MIB-W is set to the OFF position, disabling ground fault detection feed-through from the node on the right. The node on the right can be any network node.

NOTE: This drawing is a sample; all boards shown in Figure 3.9 may be used in place of the MIB-W. Refer to Figure 3.9 for equivalent switch settings, and to the board's manual (see Table 1.1).

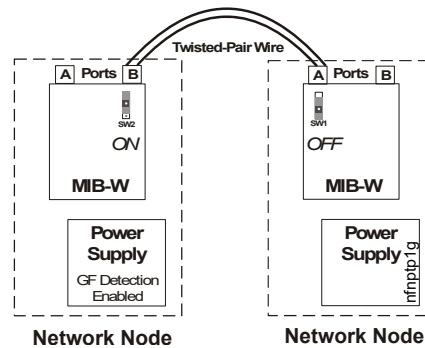

Figure 3.10 Point-to-Point Ground Fault Detection

If an RPT-W is employed, two ground fault detection schemes are possible within a point-to-point configuration. One or both nodes (refer to Figure 3.11 and Figure 3.12) may provide ground fault detection, depending on the number of repeaters and the setting of the repeater pass-through switch (SW3) at each repeater (refer to EXAMPLES 1 and 2).

EXAMPLE 1: In this example, the node on the left provides the ground fault detection, and thus must be one of the ground-fault detection nodes defined on page 17. SW2 (Port B) of the MIB on the left is set to the ON position to enable ground fault detection on Port B. The RPT-W pass-through switch (SW3) is ON, allowing the left node to provide ground fault detection for the two point-to-point wire connections on the left and right of the repeater. The Port A switch on the right MIB-W is set to the OFF position, disabling ground fault detection feed-through from the node on the right. The node on the right can be any network node.

NOTE: This drawing is a sample; all boards shown in Figure 3.9 may be used in place of the MIB-W. Refer to Figure 3.9 for equivalent switch settings, and to the board's manual (see Table 1.1).

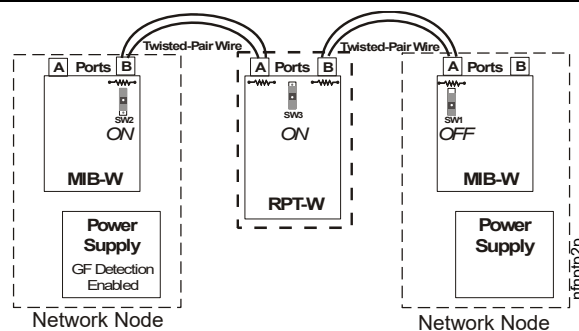

Figure 3.11 Point-to-Point (EXAMPLE 1)

EXAMPLE 2: By setting the pass-through switch (SW3) on the RPT-W to the OFF position, both nodes may provide their own ground fault detection (refer to Figure 3.12). The left node provides ground fault detection up to the RPT-W, and thus must be one of the ground-fault detection nodes defined on page 17. SW2 (Port B) is set to the ON position to enable ground fault detection pass-through on the left MIB-W.

The Port A switch on the right MIB-W is also set to the ON position, providing ground fault detection pass-through up to the RPT-W. This node must also be one of the ground-fault detection nodes defined on page 17.

NOTE: This drawing is a sample; all boards shown in Figure 3.9 may be used in place of the MIB-W. Refer to Figure 3.9 for equivalent switch settings, and to the board's manual (see Table 1.1).

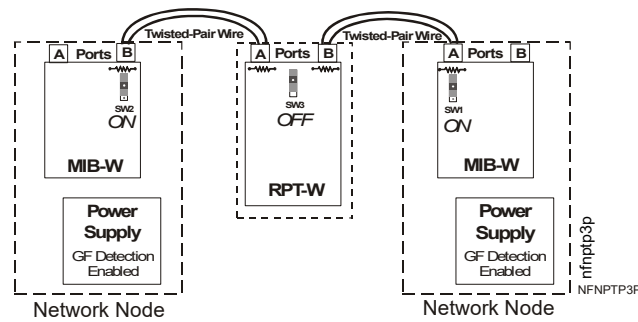

Figure 3.12 Point-to-Point (EXAMPLE 2)

EXAMPLE 3: Ground fault detection feed-through is effective for a maximum of two serially connected (point-to-point) repeaters. Therefore, a maximum of five repeaters can be connected in series when ground fault detection is required. Figure 3.13 shows how the ground fault detection feed-through switches must be arranged in order to achieve this maximum configuration.

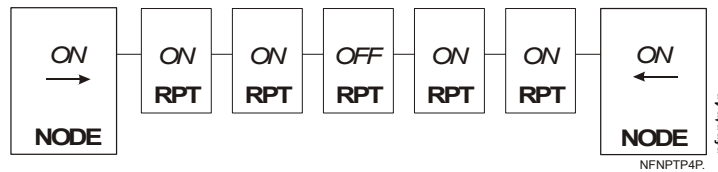

Figure 3.13 Maximum Point-to-Point Series Repeater Ground Fault Feed-Through Configuration (EXAMPLE 3)

3.7 Bus Configuration

NOTE: This drawing is a sample; all boards shown in Figure 3.9 may be used in place of the MIB-W. Refer to Figure 3.9 for equivalent switch settings, and to the board’s manual (see Table 1.1).

In a bus configuration, as in point-to-point, only one node can provide ground fault detection along the bus. The primary difference is that one node can provide ground fault detection for multiple nodes along the bus (refer to EXAMPLE 1 and 2).

EXAMPLE 1: The node second from the right in Figure 3.14 provides the ground fault detection, and thus must be one of the ground-fault detection nodes defined on page 17. SW1 (Port A) is set to the ON position to enable ground fault detection feed-through from the MIB on this node. All other nodes have ground fault detection on the MIB disabled. This includes the node on the far left of the figure, since ground fault detection has been passed through the RPT-W from the node second from the right.

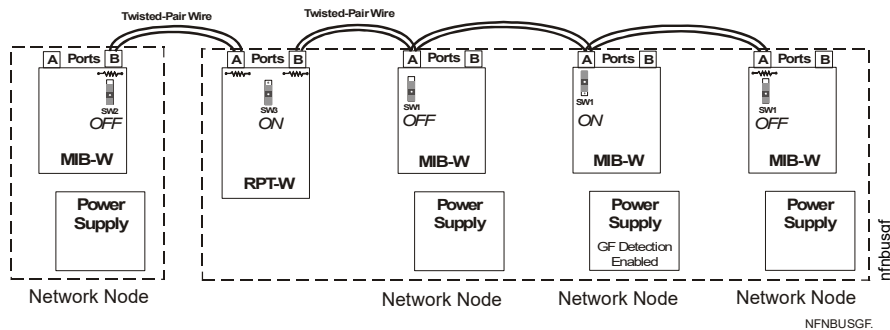

Figure 3.14 Bus (EXAMPLE 1)

NOTE: On remotely powered nodes, ground fault detection is processed through the main power supply.

EXAMPLE 2: If the repeater pass-through switch is set to the OFF position (refer to Figure 3.15), isolating the three wires on the right from the wires on the left, separate ground fault detection circuits must be fed through. The node second from the right continues to provide ground fault detection up to the RPT-W Port B, and thus must be one of the ground-fault detection nodes defined on page 17. The node on the far left of the figure provides ground fault detection up to the RPT-W Port A, and also must be one of these types of nodes.

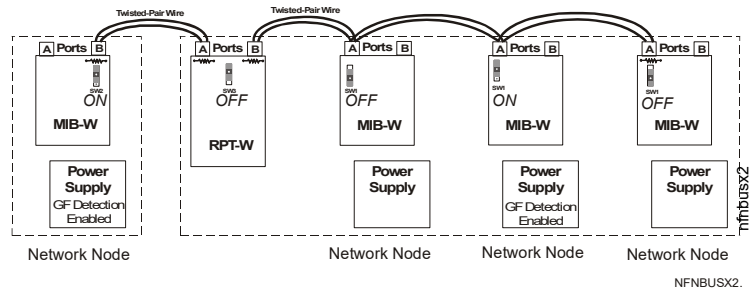

Figure 3.15 fBus (EXAMPLE 2)

Section 4: Network Wiring Requirements

When designing the wiring layout of a **NOTI•FIRE•NET™** system, the following distance limitations must be considered:

1. The length of each individual twisted pair or fiber optic network communication circuit segment is limited.
2. The system path length is limited.

NOTE: Bus configurations have additional distance limits; see “Bus Configuration” in Section 3.3.2.

NOTE: **NOTI•FIRE•NET™** network wiring is power-limited.

4.1 Limit on Circuit Segment Length

The length of each individual twisted pair or fiber optic network communication circuit segment is limited. A segment is defined as either a point-to-point connection with two nodes/repeaters, or a bus circuit encompassing multiple nodes. As illustrated in Figure 4.1, Example 1 segments 1, 2, and 3 are point-to-point circuits and Example 2 is a bus circuit encompassing five nodes. The procedures differ to determine the maximum permissible segment length for a twisted pair and a fiber-optic segment. The following paragraphs detail each procedure.

4.1.1 Limit for Twisted Pair Circuits

The length of cable for each segment in the system must fall within the range specified in Table 4.1. If the distance required for a circuit segment is greater than permitted, a Repeater module (RPT-W) must be inserted into the circuit at intervals less than, or equal to, the length restriction.

Cable type should be selected to satisfy the code requirements specific to a particular application. Refer to Table 4.1 for descriptions of specific cable types used with **NOTI•FIRE•NET™**.

NOTE: The use of more than one type of cable within any point-to-point or bus connection is not permitted. When utilizing existing cable, be sure to eliminate any cable branches or spurs.

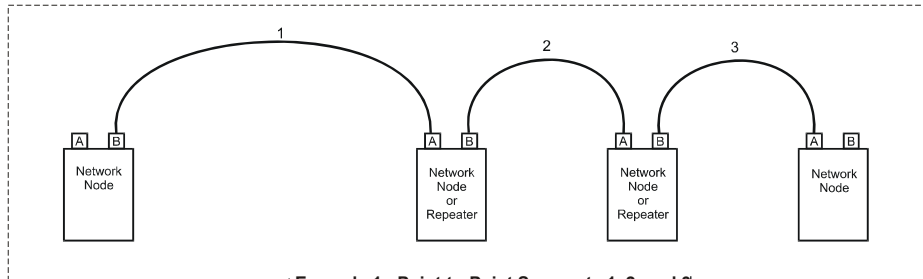

Example 1 - Point-to-Point Segments 1, 2, and 3
Each Segment is connected to only two nodes/repeaters

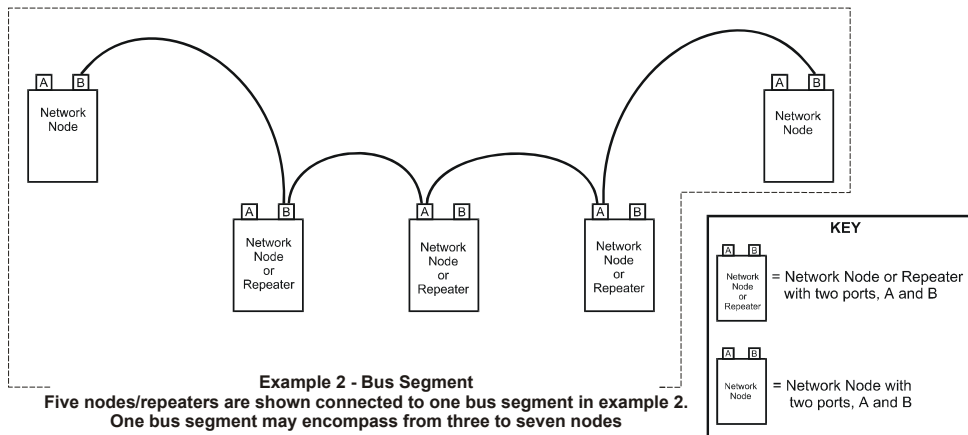

Example 2 - Bus Segment
Five nodes/repeaters are shown connected to one bus segment in example 2.
One bus segment may encompass from three to seven nodes

abrcircuit

Figure 4.1 Circuit Wiring Layout

| Cable Manufacturer, Part Number, and Number of Gauges/Conductors | Manufacturer's Specifications | Data Threshold: All Nodes And/Or Repeaters On A Cable Segment | Permissible Single Twisted Pair Range (In Feet) For Each Cable Segment (NOTE: Wire length resistance cannot exceed 15 Ohms) | |
|--|--|---|--|---------------------------|
| | | | Point-to-Point | Bus Configuration |
| | | | 2 Nodes/Repeaters | 3 to 7 Nodes/Repeaters |
| ACE Wire 61401SLL, 14 AWG, 1 Pair Shielded | FPLP, NEC Article 760 | High: | 1-1000 | 1-100 |
| | | Low: | 800-1400 | N/A |
| Aerospace 7131KK, 16 AWG, Twisted Pair | FPLP, UL 1424, UL 910 | High: | 1-1200 | 1-100 |
| | | Low: | 1000-2200 | N/A |
| ATLAS 228-18-1-1STP-2, 18 AWG, 1 Pair Unshielded | Low Cap., FPL, PVC, NEC Article 760, UL 1424 | High: | 1-800 | 1-100 |
| | | Low: | 800-1600 | N/A |
| ATLAS 228-18-1-1TP-2, 18 AWG, 1 Pair Unshielded | Low Cap., FPL, PVC, NEC Article 760, UL 1424 | High: | 1-1200 | 1-100 |
| | | Low: | 1000-3000 | N/A |
| BELDEN 5220UZ 16 AWG, 1 Pair Unshielded | FPLR, NEC Article 760 UL 1666, UL 2196 Two Hour Circuit Integrity (in conduit only) | High: | 1-1200 | 1-100 |
| | | Low: | 1200-1800 | N/A |
| BELDEN 5320UJ, 18 AWG, Twisted Pair | FPL, NEC 760, CSFM, UL 1685 | High: | 1-1200 | 1-100 |
| | | Low: | 1000-2200 | N/A |
| BELDEN 9583, 12 AWG, 1 Pair Shielded | FPLR, NEC Article 760, UL 1424 | High: | 1-600 | 1-100 |
| | | Low: | 600-1200 | N/A |
| BELDEN 9580, 14 AWG, 1 Pair Unshielded | FPLR, NEC Article 760, UL 1424 | High: | 1-1400 | 1-100 |
| | | Low: | 1300-3000 | N/A |
| BELDEN 9581, 14 AWG, 1 Pair Shielded | FPLR, NEC Article 760, UL 1424 | High: | 1-600 | 1-100 |
| | | Low: | 600-1200 | N/A |
| BELDEN 9572, 16 AWG, 1 Pair Unshielded | FPLR, NEC Article 760, UL 1424 | High: | 1-1300 | 1-100 |
| | | Low: | 1200-3000 | N/A |
| BELDEN 9575, 16 AWG, 1 Pair Shielded | FPLR, NEC Article 760, UL 1424 | High: | 1-600 | 1-100 |
| | | Low: | 600-1200 | N/A |
| BICC BM-D64-02, 16 AWG, 1 Pair Shielded | Contact Manufacturer | High: | 1-1200 | 1-100 |
| | | Low: | 1000-1600 | N/A |
| BICC BM-D51-23, 16 AWG, 1 Pair Shielded | Contact Manufacturer | High: | 1-1400 | 1-100 |
| | | Low: | 1200-2000 | N/A |
| BRAND-REX 93782-01, 16 AWG, 1 Pair Shielded | Contact Manufacturer | High: | 1-1400 | 1-100 |
| | | Low: | 1200-2000 | N/A |

Table 4.1 Twisted Pair Cable Lengths per Cable Segment (1 of 5)

| Cable Manufacturer, Part Number, and Number of Gauges/Conductors | Manufacturer's Specifications | Data Threshold: All Nodes And/Or Repeaters On A Cable Segment | Permissible Single Twisted Pair Range (In Feet) For Each Cable Segment (NOTE: Wire length resistance cannot exceed 15 Ohms) | |
|--|---|---|--|---------------------------|
| | | | Point-to-Point | Bus Configuration |
| | | | 2 Nodes/Repeaters | 3 to 7 Nodes/Repeaters |
| Comtran 8696, 18 AWG TP Unshielded | FPLR, UL 1424, UL 13, UL 444, UL 1666, NEC Article 760, CSFM | High: | 1-1200 | 1-100 |
| | | Low: | 1000-2400 | N/A |
| Comtran 8698, 16 AWG TP Unshielded | FPLR, UL 1424, UL 13, UL 444, UL 1666, NEC Article 760, CSFM | High: | 1-1200 | 1-100 |
| | | Low: | 1000-2400 | N/A |
| Comtran 8706, 16 AWG TP, Unshielded | FPLR, UL 1424, UL 13, UL 444, NFPA 262, UL 910, NEC Article 760, CSFM | High: | 1-1200 | 1-100 |
| | | Low: | 1200-2400 | N/A |
| Comtran 8709, 14 AWG TP, Unshielded | FPLR, UL 1424, NFPA 262, UL 910, NEC Article 760, CSFM | High: | 1-1200 | 1-100 |
| | | Low: | 1200-2400 | N/A |
| Comtran 35777 VITALink 2C/16 16 AWG TP, Unshielded | FPLR, UL 1424, CSA C22.2 No. 208-03 FT-4 (FAS 90), IEEE 1202, CSFM | High: | 1-1200 | 1-100 |
| | | Low: | 1200-1500 | N/A |
| Comtran 35787 14 AWG 2-Hour Fire Rated shielded | FPLR UL 2196,CL3R, CMR | High: | 1-600 | 1-100 |
| | | Low: | 600-1000 | N/A |
| Comtran 36316 VITALink(14 AWG shielded twisted-pair) FPLR | FPLR | High: | 1-1000 | 1-100 |
| | | Low: | 1-1000 | N/A |
| DRAKA USA CI FPLR-2C/16NS, 16 AWG, TP, Unshielded | FPLR-CI, UL 1424, UL 1666 | High: | 1-1300 | 1-100 |
| | | Low: | 1300-1700 | N/A |
| DRAKA CABLETEQ LIFELINE CI, CIFPLR2C/14NS 14 AWG, Unshielded | FPLR-CI, UL 1424, 2196, and 1666 | High: | 1-1000 | 1-100 |
| | | Low: | 1000 - 1600 | N/A |
| Genesis GJ-854020514, 14 AWG, 1 Pair Shielded | FPLR, NEC Article 760 | High: | 1-400 | 1-100 |
| | | Low: | 400-800 | N/A |
| Genesis 4050, 18 AWG, Twisted Pair | FPL, NEC 760, UL 1424, UL 1581 | High: | 1-1200 | 1-100 |
| | | Low: | 1000-1500 | N/A |
| Genesis 4431, 18 AWG Twisted Pair | FPLR, NEC 760, UL 1424, UL 1666, CSA FT4 | High: | 1-1200 | 1-100 |
| | | Low: | 1000-1500 | N/A |
| Genesis 4433, 14 AWG, Twisted Pair | FPLR, NEC 760, UL 1424, UL 1666, CSA FT4 | High: | 1-1200 | 1-100 |
| | | Low: | 1000-2000 | N/A |
| Genesis 4631, 18 AWG, Twisted Pair | FPLR, NEC 760, UL 1424, UL 910 | High: | 1-1200 | 1-100 |
| | | Low: | 1000-2200 | N/A |

Table 4.1 Twisted Pair Cable Lengths per Cable Segment (2 of 5)

| Cable Manufacturer, Part Number, and Number of Gauges/Conductors | Manufacturer's Specifications | Data Threshold: All Nodes And/Or Repeaters On A Cable Segment | Permissible Single Twisted Pair Range (In Feet) For Each Cable Segment (NOTE: Wire length resistance cannot exceed 15 Ohms) | |
|--|---|---|--|---------------------------|
| | | | Point-to-Point | Bus Configuration |
| | | | 2 Nodes/Repeaters | 3 to 7 Nodes/Repeaters |
| Genesis 4633, 14 AWG, Twisted Pair | FPLR, NEC 760, UL 1424, UL 910 | High: | 1-1200 | 1-100 |
| | | Low: | 1000-2200 | N/A |
| Genesis 46065004, 16 AWG, 1 Pair Shielded | FPLP, NEC Article 760 | High: | 1-500 | 1-100 |
| | | Low: | 500-1000 | N/A |
| Genesis WG 78188, 18 AWG, 1 Pair Shielded | FPLP, NEC Article 760 | High: | 1-500 | 1-100 |
| | | Low: | 500-1000 | N/A |
| GUARDIAN E2582S, 18 AWG, 1 Pair Shielded | Mid-Cap., FPL, PVC, NEC Article 760, UL 1424 | High: | 1-800 | 1-100 |
| | | Low: | 800-1400 | N/A |
| GUARDIAN E2572S, 18 AWG, 1 Pair Unshielded | Mid Cap., FPL, PVC, NEC Article 760, UL 1424 | High: | 1-1200 | 1-100 |
| | | Low: | 1000-3000 | N/A |
| Lake Cable SNY141PR-NOT, 14 AWG 2 pair TP, Unshielded | FPLP, NYC LL5 | High: | 1-1000 | 1-100 |
| | | Low: | 800-1200 | N/A |
| NORDX/CDT 24572200, 22 AWG, 4 Pair Unshielded | CMR | High: | 1-1800 | 1-100 |
| | | Low: | 1400-2400 | N/A |
| NORDX/CDT 24570036, 24 AWG, 4 Pair Unshielded | CMR | High: | 1-1400 | 1-100 |
| | | Low: | 1200-2000 | N/A |
| NYC Fire Cable 51602SLL, 16 AWG, 1 Pair Shielded | Contact Manufacturer | High: | 1-800 | 1-100 |
| | | Low: | 800-1000 | N/A |
| PAIGE ELECTRIC NOTIFIER® Cable 182LN 18 AWG, 1 Pair Unshielded | FPL | High: | 1-1200 | 1-100 |
| | | Low: | 1000-3000 | N/A |
| PAIGE ELECTRIC NOTIFIER® Cable 182MRN 18 AWG, 1 Pair Unshielded | FPLR | High: | 1-1200 | 1-100 |
| | | Low: | 1000-2800 | N/A |
| PAIGE ELECTRIC NOTIFIER® Cable 182MPN 18 AWG, 1 Pair Unshielded | FPLP | High: | 1-1200 | 1-100 |
| | | Low: | 1000-2800 | N/A |
| PAIGE ELECTRIC NOTIFIER® Cable 182SMN 18 AWG, 1 Pair Shielded | FPL | High: | 1-800 | 1-100 |
| | | Low: | 800-1400 | N/A |
| PAIGE ELECTRIC NOTIFIER® Cable 182SLN 18 AWG, 1 Pair Shielded | FPL | High: | 1-800 | 1-100 |
| | | Low: | 800-1600 | N/A |

Table 4.1 Twisted Pair Cable Lengths per Cable Segment (3 of 5)

| Cable Manufacturer, Part Number, and Number of Gauges/Conductors | Manufacturer's Specifications | Data Threshold: All Nodes And/Or Repeaters On A Cable Segment | Permissible Single Twisted Pair Range (In Feet) For Each Cable Segment (NOTE: Wire length resistance cannot exceed 15 Ohms) | |
|--|---|---|--|---------------------------|
| | | | Point-to-Point | Bus Configuration |
| | | | 2 Nodes/Repeaters | 3 to 7 Nodes/Repeaters |
| Pyrotex 2/16-246T, 16 AWG TP, Mineral Insulated | UL 2196, ULC-S139, CSA | High: | 1-400 | N/A |
| | | Low: | N/A | N/A |
| Radix CI14A0702-0000-15000, 14 AWG TP Unshielded | FPL 2-Hour UL 1424, UL 2196, NEC Article 760 | High: | 1-1200 | 1-100 |
| | | Low: | 1200-2000 | N/A |
| Radix CI16A0102-0000-15000, 16 AWG TP, Unshielded | FPL 2-Hour UL 1424, UL 2196, NEC Article 760 | High: | 1-1200 | 1-100 |
| | | Low: | 1200-2000 | N/A |
| Radix DuraLife CFU18A0102 | 18AWG unshielded FPLP-CI | High: | 1-1000 | 1-100 |
| | | Low: | 800-1250 | N/A |
| Radix DuraLife CFU16A0102 | 16AWG unshielded FPLP-CI | High: | 1-1000 | 1-100 |
| | | Low: | 800-1250 | N/A |
| Raychem CI-2C16UNSH 16 AWG, Twisted Pair | FPLR-CI NEC 760, UL 1424, UL 1666, UL 2196, ULC 5139, CSA Type FAS105, FT4 | High: | 1-1000 | 1-100 |
| | | Low: | 800-1200 | N/A |
| Raychem CI-2C18UNSH, 18 AWG TP, Unshielded | FPLR-CI NEC 760, UL 1424, UL 1666, UL 2196, ULC 5139, CSA Type FAS105, FT4 | High: | 1-1000 | 1-100 |
| | | Low: | 800-1200 | N/A |
| REMEE Products, NY514SHM1RHPHB, 14 AWG, TP Shielded | FPLP, NYC LL5 | High: | 1-1000 | 1-100 |
| | | Low: | 800-1400 | N/A |
| Shawflex 64220M140118700, 14 AWG TP, Shielded, Armored | CSA 22.2 | High: | 1-500 | N/A |
| | | Low: | 500-800 | N/A |
| SIGNAL 84743-06-14, 18 AWG, 1 Pair Shielded | Mid-Cap., FPLP, PVC, NEC Article 760, UL 1424 | High: | 1-600 | 1-100 |
| | | Low: | 600-1200 | N/A |
| SIGNAL 98281-06-04, 18 AWG, 1 Pair Shielded | Mid-Cap., FPL, PVC, NEC Article 760, UL 1424 | High: | 1-600 | 1-100 |
| | | Low: | 600-1200 | N/A |
| SIGNAL 82802-06-14, 18 AWG, 1 Pair Unshielded | Mid-Cap., FPLP, PVC, NEC Article 760, UL 1424 | High: | 1-1200 | 1-100 |
| | | Low: | 1000-2800 | N/A |
| SIGNAL 98181-06-04, 18 AWG, 1 Pair Unshielded | Mid-Cap., FPL, PVC, NEC Article 760, UL 1424 | High: | 1-1200 | 1-100 |
| | | Low: | 1000-2800 | N/A |
| SIGNAL 962034619, 24 AWG, 3 Pair Unshielded | CLZ/CMR | High: | 1-1400 | 1-100 |
| | | Low: | 1200-2000 | N/A |

Table 4.1 Twisted Pair Cable Lengths per Cable Segment (4 of 5)

| Cable Manufacturer, Part Number, and Number of Gauges/Conductors | Manufacturer's Specifications | Data Threshold: All Nodes And/Or Repeaters On A Cable Segment | Permissible Single Twisted Pair Range (In Feet) For Each Cable Segment (NOTE: Wire length resistance cannot exceed 15 Ohms) | |
|--|--|---|--|---------------------------|
| | | | Point-to-Point | Bus Configuration |
| | | | 2 Nodes/Repeaters | 3 to 7 Nodes/Repeaters |
| SIGNAL 962044619, 24 AWG, 4 Pair Unshielded | CLZ/CMR | High: | 1-1400 | 1-100 |
| | | Low: | 1200-2000 | N/A |
| SIGNAL 962064619, 24 AWG, 6 Pair Unshielded | CLZ/CMR | High: | 1-1400 | 1-100 |
| | | Low: | 1200-2000 | N/A |
| SIGNAL 962624619, 24 AWG, 4 Pair Unshielded | CMR/MRP | High: | 1-1400 | 1-100 |
| | | Low: | 1200-2000 | N/A |
| SIGNAL9669544623, 24 AWG, 4 Pair Unshielded | CMP/MPP | High: | 1-1400 | 1-100 |
| | | Low: | 1200-2000 | N/A |
| WEST PENN WIRE D999, 12 AWG, 1 Pair Shielded | FPL, PVC, NEC, Article 760, UL 1424 and 1581 | High: | 1-800 | 1-100 |
| | | Low: | 800-1400 | N/A |
| WEST PENN WIRE 991, 14 AWG, 1 Pair Shielded | FPLR, UL 1424 and UL 1666 | High: | 1-800 | 1-100 |
| | | Low: | 600-1000 | N/A |
| WEST PENN WIRE D991, 16 AWG, 1 Pair Shielded | FPL, NEC Article 760 | High: | 1-1000 | 1-100 |
| | | Low: | 1000 - 1600 | N/A |
| WEST PENN WIRE D995, 14 AWG, 1 Pair Shielded | FPL, PVC, NEC, Article 760, UL 1424 and 1581 | High: | 1-800 | 1-100 |
| | | Low: | 800-1400 | N/A |
| WEST PENN WIRE AQ225, 16 AWG, 1 Pair Unshielded | FPL or PLTC Direct Burial Water Blocked | High: | 1-1400 | 1-100 |
| | | Low: | 1200-2800 | N/A |
| WEST PENN WIRE AQ294, 16 AWG, 1 Pair Shielded | FPL or PLTC Direct Burial Water Blocked | High: | 1-1000 | 1-100 |
| | | Low: | 1000-1600 | N/A |
| WEST PENN WIRE D980 18 AWG TP, Unshielded | FPLR, NEC Article 760, UL 1666, Riser Flame Tested | High: | 1-1200 | 1-100 |
| | | Low: | 1000-3000 | N/A |
| WEST PENN WIRE D990 16 AWG TP, Unshielded | FPLR, NEC Article 760, UL 1666, Riser Flame Tested | High: | 1-1200 | 1-100 |
| | | Low: | 1000-2400 | N/A |
| WEST PENN WIRE D975, 18 AWG, 1 Pair Shielded | FPL, PVC, NEC Article 760, UL 1424 and 1581 | High: | 1-800 | 1-100 |
| | | Low: | 800-1400 | N/A |

NOTE: In the event of a panel failure at a wire node, the data is not regenerated locally. The node may be manually bypassed using the NBB-1 Assembly. In this case, the total length of wire becomes the sum of both lengths of wire between operating nodes. If the total length exceeds the maximum allowable length for a given threshold, the network may lose communication. Separately powered repeater(s) may be employed at each node in a point-to-point connection to ensure data regeneration.

Table 4.1 Twisted Pair Cable Lengths per Cable Segment (5 of 5)

4.1.2 Limit for Fiber Optic Circuits

The attenuation of cabling between two nodes/repeaters (fiber optic circuits are point-to-point) is limited by cable choice. If the distance required for a circuit segment is greater than permitted, a Repeater module (RPT-F) must be inserted into the circuit at intervals less than, or equal to, the attenuation length restriction.

These attenuation figures apply to the MIB-F, MIB-WF, RPT-WF, RPT-F, RPT-WF, NCM-F, NCS(X)-F-ONYX, ONYXWorks-NF, NCS-F, and NAM-232F (multimode fiber):

- 62.5/125µm cable 8dB limit
- 50/125µm cable 4.2dB limit

The actual attenuation can be measured end-to-end with fiber-optic industry standard equipment using a test wavelength of 850 nanometers. For a quick approximation, perform the following calculations:

- a. Calculate loss due to cable.** Look up the rated dB loss per foot within the cable manufacturer's specifications. Multiply this by the length of cable between the two nodes/repeaters to determine loss due to cable: $Loss = (loss/ft.) \times (length \text{ in feet})$.
- b. Calculate loss due to connectors/splices.** Look up the dB loss for each connector and splice, and add all figures to determine loss due to connectors/splices.
- c. Calculate total loss.** Add the attenuation factors obtained in steps a. and b. This will provide an approximate attenuation total.

4.2 Limit on System Path Length

The total system path length is the distance a signal would have to travel from one end of the network to the other end along wire/cable or through nodes/repeaters as shown in Figure 4.2. Because it takes real time for a signal to travel along a wire or through a device, there is a propagation delay that becomes significant only if dealing with extremely large networks. The network communications protocol defines a time-out threshold beyond which the propagation delay appears to be a broken wire/cable.

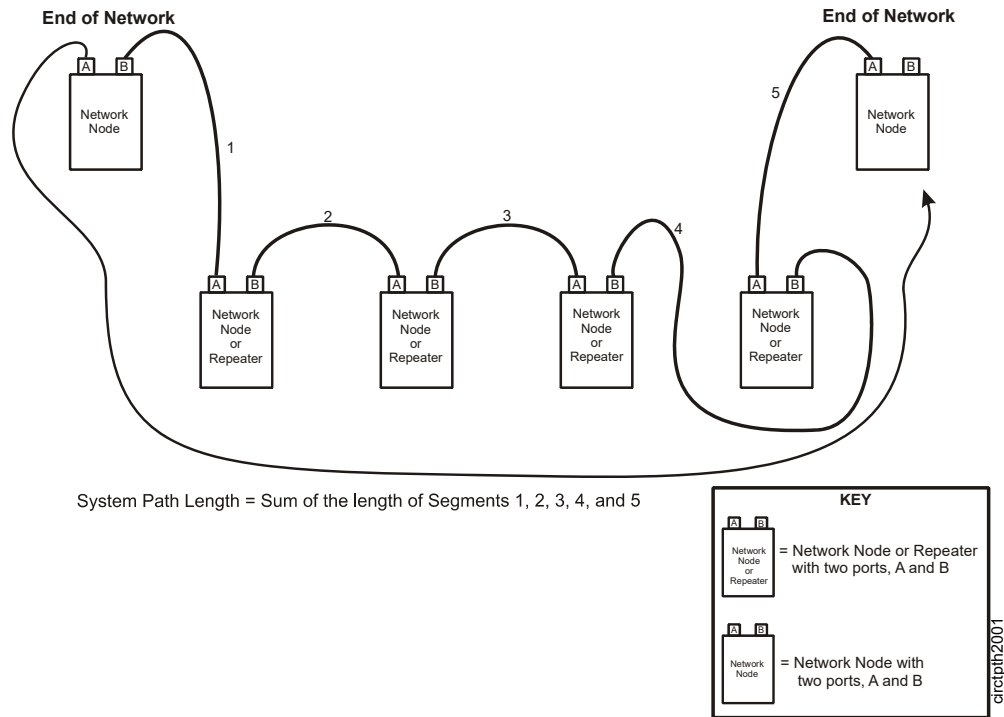

Figure 4.2 NOTI•FIRE•NET™ Circuit Paths

Figure 4.3 shows the time-out threshold in the section where it might be crossed by the values for an extremely large network that uses maximum system segment length between all segments. Plot your proposed number of nodes/repeaters against your proposed total system path length; this plot point must remain under the time-out threshold. The dotted line in Figure 4.3 demonstrates where these values for a **NOTI•FIRE•NET™** network might be, given wire that permits 2000 feet between nodes. Any point in the gray area would be valid for this wire. Use the maximum distance values in Table 4.1 to check your system. The overall distance in feet divided by the number of nodes/repeaters must be less than the maximum distance permitted in Table 4.1 for each cable segment.

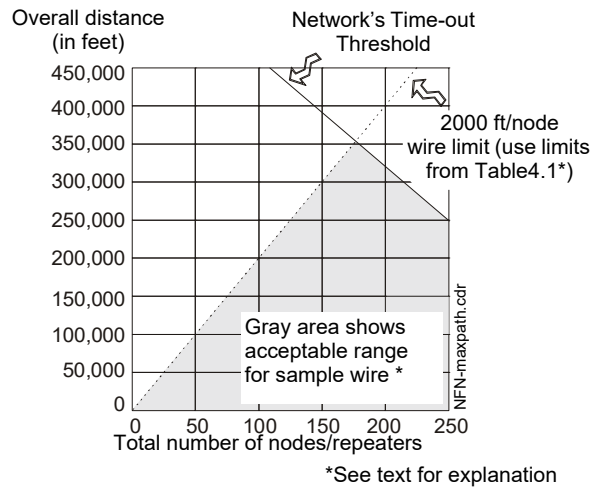

Figure 4.3 Maximum Nodes and Maximum Total System Path Length for Extremely Large Networks

Appendix A: FCC Considerations

In order to comply with FCC regulations regarding radio frequency emissions, a ferrite cylinder (NOTIFIER PN 29087) must be installed on every twisted pair circuit connected to a MIB-W (Two cylinders included) and MIB-WF (one cylinder included).

Installation on SIB-NET

The following steps must be completed to install the ferrite cylinder on the SIB-NET (refer to Figure A.1):

1. Thread the twisted pair (two pairs for a bus connection) through the ferrite cylinder.
2. Slide the cylinder along the pair(s) toward the entrance point on the cabinet (not toward the MIB) so that the edge of the cylinder and the cabinet are separated by no more than three inches.
3. Secure the ferrite cylinder to the wiring with the supplied tie wrap at each end of the cylinder.
4. If used, repeat for the remaining twisted pair(s) on a MIB-W (second port).

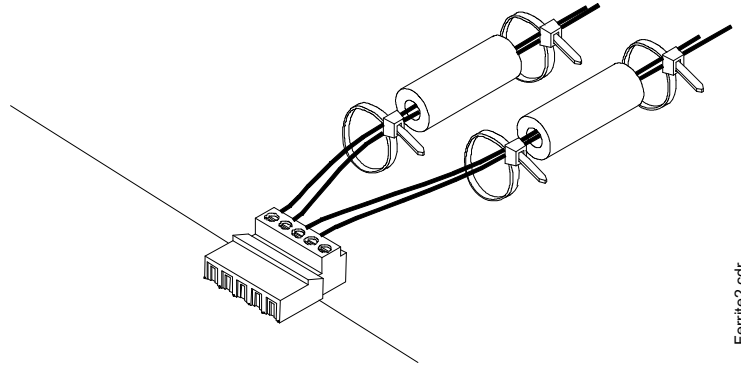

Figure A.1 Installation of the Ferrite Cylinder on SIB-NET

Manufacturer Warranties and Limitation of Liability

Manufacturer Warranties. Subject to the limitations set forth herein, Manufacturer warrants that the Products manufactured by it in its Northford, Connecticut facility and sold by it to its authorized Distributors shall be free, under normal use and service, from defects in material and workmanship for a period of thirty six months (36) months from the date of manufacture (effective Jan. 1, 2009). The Products manufactured and sold by Manufacturer are date stamped at the time of production. Manufacturer does not warrant Products that are not manufactured by it in its Northford, Connecticut facility but assigns to its Distributor, to the extent possible, any warranty offered by the manufacturer of such product. This warranty shall be void if a Product is altered, serviced or repaired by anyone other than Manufacturer or its authorized Distributors. This warranty shall also be void if there is a failure to maintain the Products and the systems in which they operate in proper working conditions.

MANUFACTURER MAKES NO FURTHER WARRANTIES, AND DISCLAIMS ANY AND ALL OTHER WARRANTIES, EITHER EXPRESSED OR IMPLIED, WITH RESPECT TO THE PRODUCTS, TRADEMARKS, PROGRAMS AND SERVICES RENDERED BY MANUFACTURER INCLUDING WITHOUT LIMITATION, INFRINGEMENT, TITLE, MERCHANTABILITY, OR FITNESS FOR ANY PARTICULAR PURPOSE. MANUFACTURER SHALL NOT BE LIABLE FOR ANY PERSONAL INJURY OR DEATH WHICH MAY ARISE IN THE COURSE OF, OR AS A RESULT OF, PERSONAL, COMMERCIAL OR INDUSTRIAL USES OF ITS PRODUCTS.

This document constitutes the only warranty made by Manufacturer with respect to its products and replaces all previous warranties and is the only warranty made by Manufacturer. No increase or alteration, written or verbal, of the obligation of this warranty is authorized. Manufacturer does not represent that its products will prevent any loss by fire or otherwise.

Warranty Claims. Manufacturer shall replace or repair, at Manufacturer's discretion, each part returned by its authorized Distributor and acknowledged by Manufacturer to be defective, provided that such part shall have been returned to Manufacturer with all charges prepaid and the authorized Distributor has completed Manufacturer's Return Material Authorization form. The replacement part shall come from Manufacturer's stock and may be new or refurbished. THE FOREGOING IS DISTRIBUTOR'S SOLE AND EXCLUSIVE REMEDY IN THE EVENT OF A WARRANTY CLAIM.

Warn-HL-08-2009.fm

NOTIFIER
12 Clintonville Road
Northford, CT 06472-1610 USA
203-484-7161
www.notifier.com

