

D6021/D6031 Double Unit Series (Push Side) Power Operator Installation Instructions

! WARNING

This product can expose you to lead which is known to the state of California to cause cancer and birth defects or other reproductive harm. For more information go to www.P65warnings.ca.gov.

Pour la version française voir www.nortondoorcontrols.com.
READ AND FOLLOW ALL INSTRUCTIONS. SAVE THESE INSTRUCTIONS.

D6021 Push Side up to 110° opening

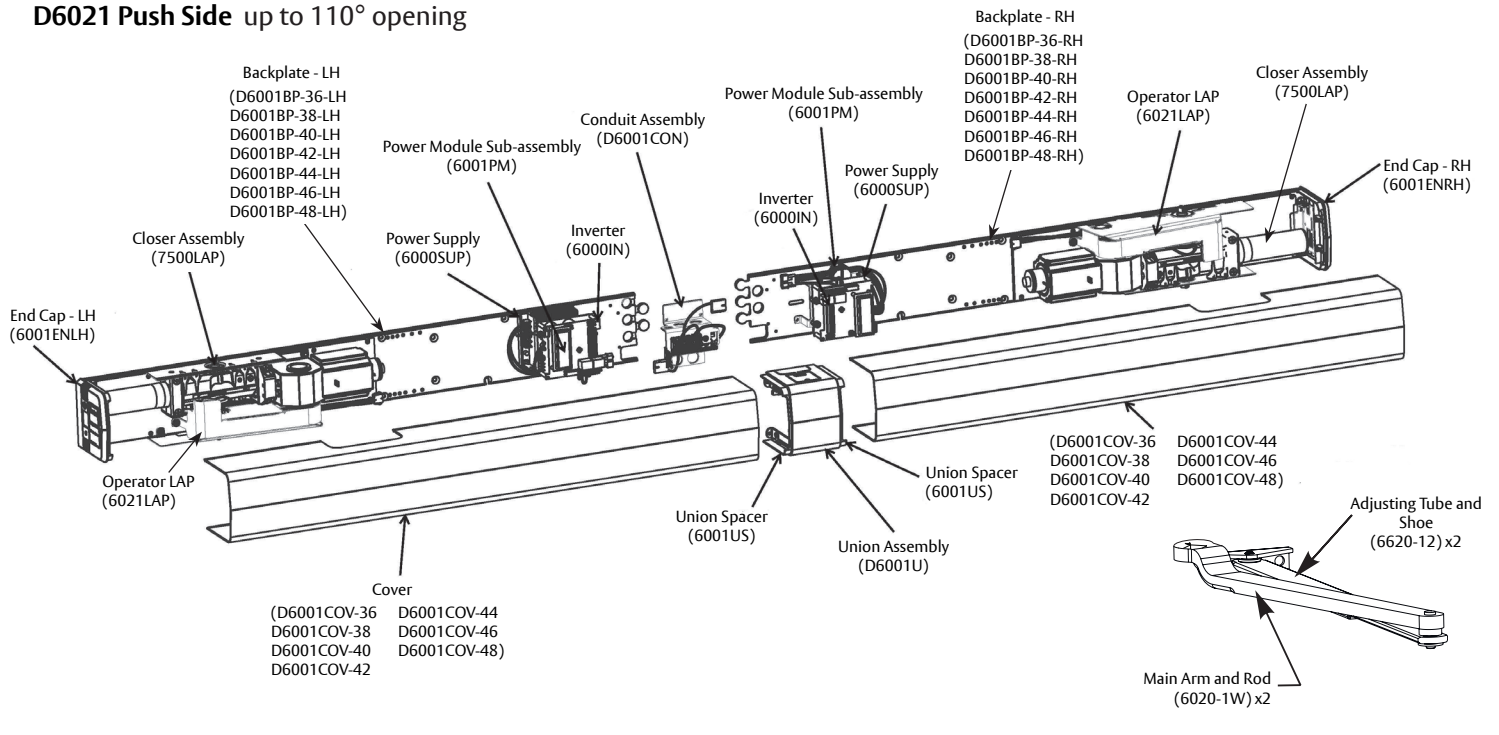

D6031 Push Side (Handed) 110° to 180° opening

All components above with 6030-1W main arm and rod instead of 6020-1W

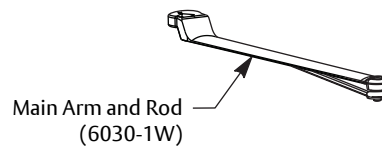

Tools Needed

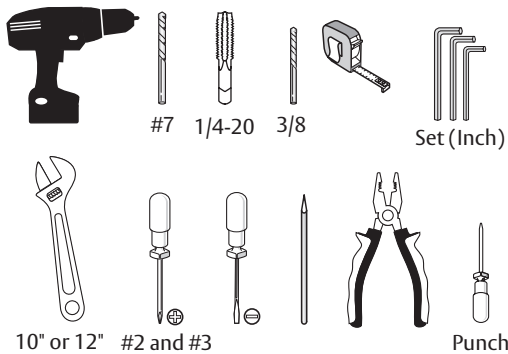

Supplied Fasteners per Operator

NOTE: Fasteners shown are for this specific installation. (Fasteners for other installations are included in package.)

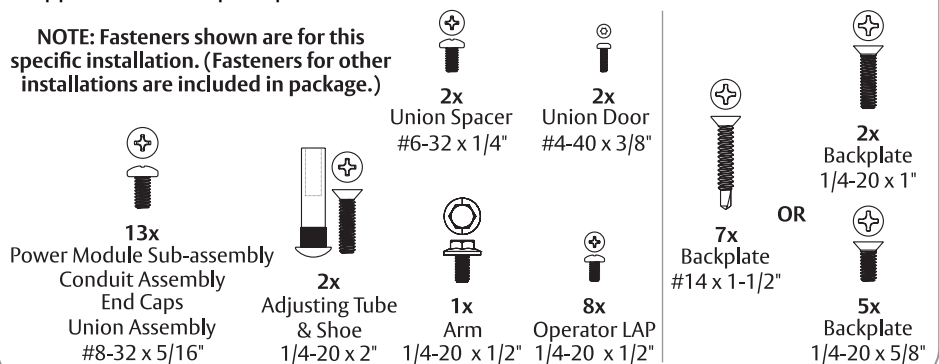

Contents

Certifications and Standards.....2

Product Safety Warnings2

General Information.....3

Before You Begin4

Mounting Hardware Chart.....4

Technical Data4

Prepare Frame and Doors.....5

Install Operators8

Install Track and Arm11

Adjustments12

Power Operators.....13

Sync Operators.....14

Finalize Installation.....15

General Electrical Information15

Wiring Options.....16

Troubleshooting27

D6021/D6031 Template.....28

Certifications and Standards

- ETL Certified: Operator conforms to ANSI/UL standard 325 for automatic closing doors and UL10C Positive Pressure Fire Test for Door Assemblies.
- ANSI A156.19: These products are designed to conform to this specification “for power assist and low energy power operated doors.” These products are designed to exceed all the requirements for “Low Energy Power Operated Door”.
- Americans with Disabilities Act (A.D.A.): These door operators can be installed and adjusted to conform with A.D.A. regulations.
- ANSI A117.1: These door controls permit door assemblies to conform to the requirements of this specification “for buildings and facilities - providing accessibility and usability for physically handicap people”.

Product Safety Warnings

WARNING: To reduce risk of injury to person, use this operator only with Pedestrian Swing doors. **FOR INDOOR USE ONLY**

1. READ AND FOLLOW ALL INSTRUCTIONS.
2. Install only on a properly operating and balanced door. A door that is operating improperly could cause severe injury. Have qualified service personnel make repairs to any hardware before installing the operator.
3. Remove, or make inoperative, all locks (unless mechanically and/or electrically interlocked to the power unit) that are connected to the door before installing the operator.
4. Do not connect the door operator to the source power until instructed to do so.
5. Never let children operate or play with door controls. Keep remote control (when provided) away from children.
6. Personnel should keep away from a moving door in motion.
7. Test door’s features at least once a month. After adjusting either force or limit of travel, retest door operator’s features. Failure to adjust operator properly may cause severe injury or death.
8. KEEP DOOR PROPERLY OPERATING. An improperly operating door could cause severe injury or death.
9. SAVE THESE INSTRUCTIONS.

General Information

Operation:

Your Low Energy Operator can be configured in three variations to meet the standards:

1. Push plates, Wave-to-open switches, etc. are available to activate the operator.
2. Push & Go can be enabled. In this mode, your door is pushed (or pulled) slowly 15° manually, and then automatically opens to full open position.
3. Door can be used as a manual door. The door will work and act like a standard door closer, with or without power, when pushed or pulled open manually. If Push & Go is enabled and door is opened quickly, door will function as a manual door (energy save feature). Push plates are still active.

If desired, overhead presence devices can be provided for an extra level of protection. Consult local authority having jurisdiction. These are not required by current ANSI/BHMA A156.19 standards.

Opening:

When an opening signal is received by the control unit, the door opens to the fully open position. The open position is held by the motor and is adjustable from 0 to 30 seconds. If the door is obstructed while opening, the door will stop; the operator will sense obstruction (obstruction time is adjustable from 0 to 5 seconds) and the door will close.

NOTE: Door must be visible by person operating activation switch(s). Switch(s) to comply with ANSI/BHMA requirements. Auxiliary door stop (by others) required.

Closing:

When the hold open time has elapsed, the door closer will close the door automatically. The door will slow to low speed at latch before it reaches the fully closed position. The door is kept closed by spring force of the closer. If the door is obstructed while closing, the door will stop against the obstruction; the operator will sense obstruction and reopen to fully open position after obstruction time has been reached. Once the hold open time has elapsed a second time, the door closer will close the door automatically. If the door is obstructed during this second closing cycle, the door will stop and rest against the obstruction using only the force of the closer spring. To reset, allow door to fully close and re-activate push plates to test operation.

Infinite Hold Open:

An optional feature to be used if door is desired to be held open for more than 30 seconds.

Set selector mode switch on underside of union assembly to hold open. Door will immediately begin to open to the fully open position. Once door is fully open, brake on end of motor energizes holding door in open position. To release from hold open, if door is set up for executive operation (see page 20 or 22 for executive wiring instructions), door can be closed with activation device. A pull on the door will also allow the unit to be taken out of hold open. Once door has closed, the door will reopen to fully open position unless activation device is pressed or selector mode switch is changed from hold open position.

NOTE: Door must be visible by person operating activation switch(s). Switch(s) to comply with ANSI/BHMA requirements. Auxiliary door stop (by others) required.



WARNING: Make sure (120V, 60Hz) input power is turned OFF at facility's main circuit breaker before proceeding with installation

Before You Begin

- All dimensions are given in inches. DO NOT scale drawings.
- Thickness recommended for reinforcements in hollow metal doors and frames is charted.
- This template information based upon use of 5" maximum width butt hinges.
- Maximum frame reveal is 6-7/8" for both 6021 and 6031 units.
- Before beginning the installation, verify that the door frame is properly reinforced and is well anchored in the wall. Frame header must be straight - without warp or bow.
- Unreinforced hollow metal frames and aluminum frames should be prepared and fitted with 1/4-20 blind rivet nuts, furnished by others.
- Concealed electrical conduit and concealed switch or sensor wires should be pulled to the frame before proceeding.



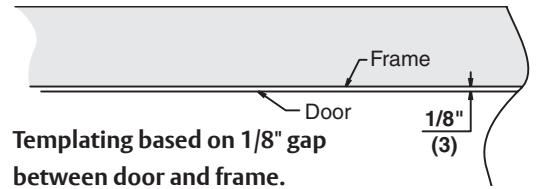

Fasteners for Frame:

- 1/4-20 Machine screws for hollow metal and aluminum.
- No. 14 x 2-3/4" (70mm) long sheet metal screws for wood.



Templating based on 1/8" gap between door and frame.

Hollow Metal Door Frame Reinforcing		
Frame Material	Reinforcing	
	Recommended	Min. Required
12 Ga. .105 (2.66)	12 Ga. .105 (2.66)	18 Ga. .048 (1.21)
14 Ga. .075 (1.90)	10 Ga. .134 (3.41)	12 Ga. .105 (2.66)
16 Ga. .060 (1.52)	10 Ga. .134 (3.41)	12 Ga. .105 (2.66)
18 Ga. .048 (1.21)	8 Ga. .164 (4.18)	10 Ga. .134 (3.41)

Mounting Hardware		Door or Frame	Drill
	Backplate: 14 x 1-1/2 Flat Head Self Drilling Screw	Wood	3/16" (4.76mm)
	Backplate: 1/4-20 x 1 Flat Head Machine Screw	Metal	Drill #7 (.201 dia. or 5.10mm) Tap 1/4-20
	Backplate: 1/4-20 x 5/8 Flat Head Machine Screw		
	Adjusting Tube and Shoe: Sex Nut and Bolt (SNB) (optional)	Hollow Metal	9/32" (7.00mm) thru 3/8" (9.50mm) door face opposite to closer
		Aluminum or Wood	3/8" (9.50mm) thru

Technical Data

Input power:	120VAC, 60Hz
Power consumption:	.9 amps
Circuit breaker:	3 amps
Power supply:	24 V DC, max. 2.2 amp.
Door width:	36" - 48" (91-122 cm)
Door weight:	100-250 lb. (43-113 kg)
Door opening angle:	up to 110° with reveal of 3" (7.6 cm) max
Hold open time:	0-30 seconds (A.D.A. 5 seconds min.) Indefinite for optional Infinite Hold Open

Notes:

- Permanent wiring is to be implemented as required by local codes.
- Activation devices: push plates, access control, mats, touchless wall switches, etc.
- Maximum wire size is:
12AWG at terminals LINE and NEUTRAL (120VAC; 60Hz) on Power Input Terminal mounted on inside of end cap.
14AWG at all other terminals
- Rate of operation shall not exceed 300 cycles of opening and closing per hour.

Prepare Frame and Door

Become familiar with operator components and fasteners. It is recommended that components remain in boxes until installed. Verify there is minimum ceiling clearance for operator installation before proceeding. (Figure 1)

A. Prepare frame.

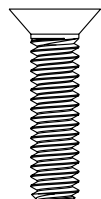

OR

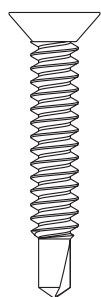

1. Determine if push or pull installation. (Figure 2)

NOTE: These instructions are for Pair of Doors, PUSH only. See 80-9360-1029-020 instructions for D6011/D6051 or 80-9360-1031-020 instructions for D6061/D6071 Push installation.

2. Frame header MUST be flat / without twists. Backplates can be used as reference.

NOTE: If frame is not flat or is twisted, additional steel back plates or shimming is required. Failure to mount units properly can result in improper function of operator or inability to snap on covers.

3. Mark center of opening on frame header between jamb.
4. Using chart, mark from center of opening to left. (Figure 3)

NOTE: Template provided on page 28.

5. Measure 5/16" up from bottom of frame header and mark at Dim A and Dim B locations.
6. Drill holes.
7. Using supplied backplate screw pack in Box 1, insert screws into prepared mounting holes.

For Metal Frame: Use two (2) 1/4-20 x 1" flat head machine screws.

For Wood Frame: Use two (2) #14 x 1-1/2" flat head self-drilling screws.

NOTE: Do not tighten mounting screws at this time. Leave 5/16" minimum (thickness of backplate) between frame face and back of screw head.

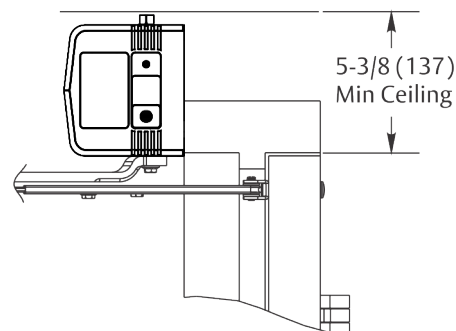

Figure 1

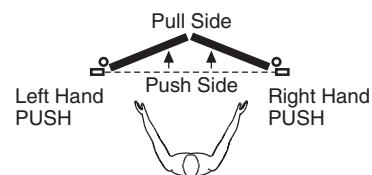
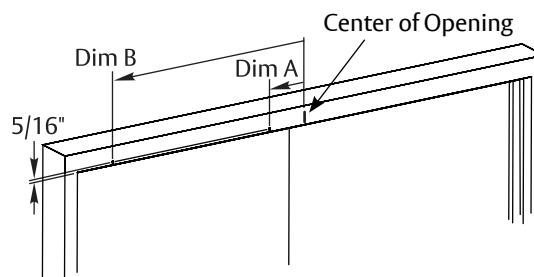

Figure 2



Door Size	Dim A	Dim B
Pair of 36" doors:	5-9/16" (141mm)	30-9/16" (776mm)
Pair of 38" doors:	7-9/16" (192mm)	32-9/16" (827mm)
Pair of 40" doors:	9-9/16" (243mm)	34-9/16" (878mm)
Pair of 42" doors:	11-9/16" (294mm)	36-9/16" (929mm)
Pair of 44" doors:	13-9/16" (344mm)	38-9/16" (979mm)
Pair of 46" doors:	15-9/16" (395mm)	40-9/16" (1030mm)
Pair of 48" doors:	17-9/16" (446mm)	42-9/16" (1081mm)

Figure 3

Prepare Frame and Door

B. Mount Backplates.

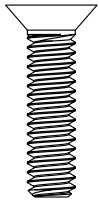

OR

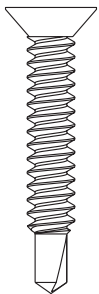

1. Select backplate with 2 “fingers” for interlocking plates and marked “Mount This Plate First” from Box 1. (This is LEFT backplate.)
2. Slide left backplate over mounting screws. (Figure 4)

NOTE: Left backplate conduit slot is ALWAYS at bottom of plate and toward center of opening.

3. Use level in backplate to align then tighten mounting screws. (Figure 4)
4. Interlock right backplate (3 “fingers”) from Box 2 with left backplate. (Figure 5)

NOTE: Right backplate conduit slot is ALWAYS at bottom of plate and center of opening.

5. Use level on right backplate to ensure proper alignment. (Figure 5)
6. Using backplate as template, mark conduit slot and Dim D mounting hole. (Figure 5)

NOTE: Dim D should be 5/16" up from bottom of frame header if backplate is properly aligned.

7. Drill hole for mounting screw at Dim D.
8. Using supplied backplate screw pack in Box 2, insert screw into prepared mounting hole. (Figure 6)

For Metal Frame: Use one (1) 1/4-20 x 1" flat head machine screw.

For Wood Frame: Use one (1) #14 x 1-1/2" flat head self-drilling screw.

NOTE: Do not tighten mounting screw at this time. Leave 5/16" minimum (thickness of backplate) between frame face and back of screw head.

9. Using countersunk holes in backplates as a template, drill/tap remaining eleven (11) mounting holes: 1/4-20 for steel frame or #14 for wood frame. (Figure 6)

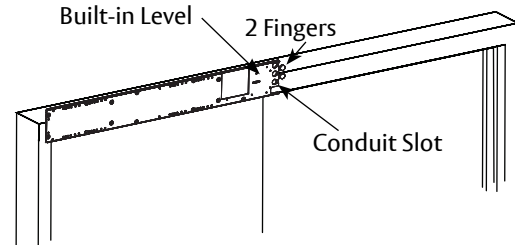

Figure 4

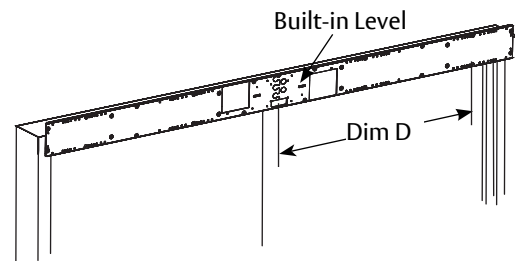

Figure 5

Door Size	Dim D
Pair of 36" doors:	30-9/16" (776mm)
Pair of 38" doors:	32-9/16" (827mm)
Pair of 40" doors:	34-9/16" (878mm)
Pair of 42" doors:	36-9/16" (929mm)
Pair of 44" doors:	38-9/16" (979mm)
Pair of 46" doors:	40-9/16" (1030mm)
Pair of 48" doors:	42-9/16" (1081mm)

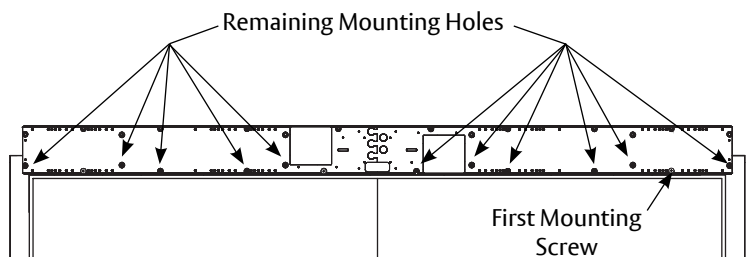
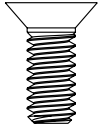

Figure 6

Prepare Frame and Door

C. Secure Backplates.



OR



- Secure backplates to frame using eleven (11): 1/4-20 x 5/8" machine screws or 1/4 x 1-1/2" self-drilling screws from screw packs in Boxes 1 and 2. (Figure 7)



NOTE: It is important to properly secure top edge of backplate. Use of blocking (supplied by others) or shims (provided) to fill gap between backplate and wall above header is **HIGHLY** recommended. Material must comply with local codes. Failure to properly secure top of backplate could result in operator being allowed to 'rock' during operation. This could result in damage to operator and diminish operator function. (Figure 7)

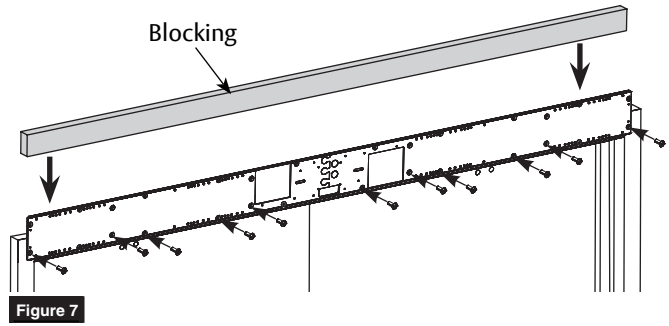

Figure 7

D. Prepare doors for Adjusting Tubes and Shoes.

- Locate and prepare adjusting tube and shoe holes in doors. (Figure 8)

NOTE: Template provided on page 28.

- Drill 3/8" (9.5mm) through (4 places) for sex bolts.

A Dimension	Operator Model
13-1/8" (333mm)	6021
10-3/8" (264mm)	6031

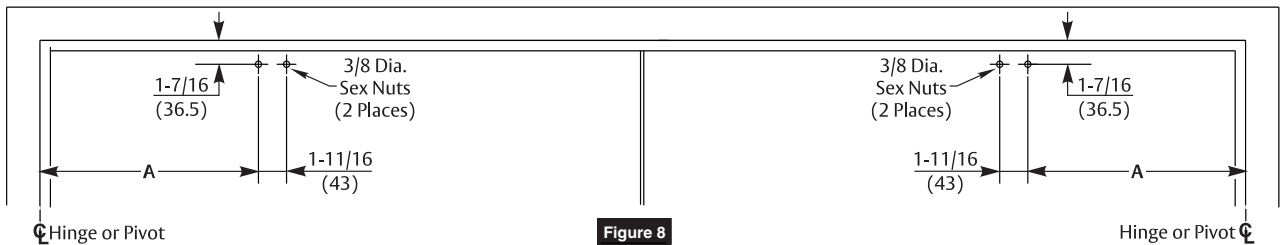

Figure 8

Install Operator



A. Install End Caps.

1. Secure end caps to each end of connected backplates using four (4) (two each) #8-32 x 5/16" Phillips pan head screws. (Figure 9)

NOTE: Orient end caps so that text on labels is legible when observed from ground.

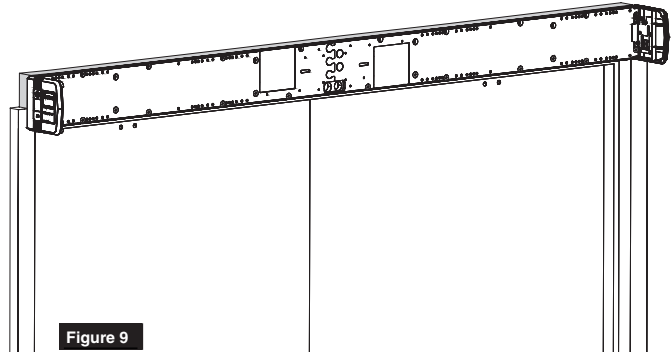
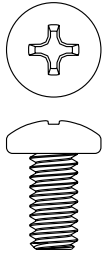

Figure 9



B. Install Operator LAP.

NOTE: Backplates are printed with text to assist installation.

1. With backplates mounted to frame, use text to locate holes along bottom of backplates that correspond to your specific closer installation. (Figure 10)
2. Insert two (2) 1/4-20 x 1/2" Phillips pan head screws on each backplate into appropriate engraved locations. Leave a 5/16" minimum gap between backplate and underside of screw head.
3. On each backplate, orient LAP so spring tube of closer is pointed toward closest hinge edge of frame. Slide each LAP over two (2) screws and tighten. (Figure 11)

NOTE: When properly oriented, spring tube is at bottom on left hand backplate (Figure 12) and at top on right hand backplate.

4. For each LAP, use six (6) 1/4-20 x 1/2" Phillips head screws to secure. (Figure 12)

NOTE:

- Holes in LAP align with threaded holes in backplate.
- Screws to be torqued to 80 in-lb minimum.

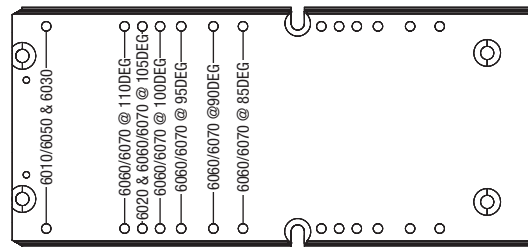

Figure 10

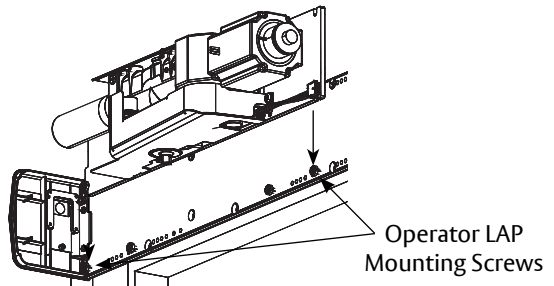

Figure 11 Left Hand LAP shown

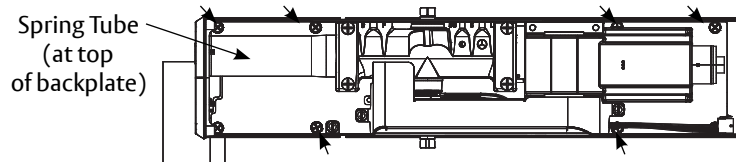

Figure 12 Remaining LAP Mounting Screws - Left Hand View

Install Operator



C. Install Conduit Assembly and wire to building.

1. Orient conduit assembly so two (2) conduit holes are at bottom and text on wire input label is legible. (Figure 13)
2. Secure assembly to backplate using four (4) #8-32 x 5/16" Phillips head screws. (Figure 13)

WARNING: BUILDING POWER MUST BE OFF BEFORE PROCEEDING!

3. Secure conduits to conduit assembly (surface or concealed conduit). (Figure 14)
4. Wire building 120VAC to conduit assembly – LINE, NEUTRAL, and GROUND. (See page 15 for General Electrical Information.)
5. Wire 24VDC for accessories to conduit assembly 24VDC + / - as required. (See page 15 for General Electrical Information.)

WARNING: DO NOT TURN ON BUILDING POWER UNTIL DIRECTED TO DO SO! RISK OF INJURY OR DEATH!

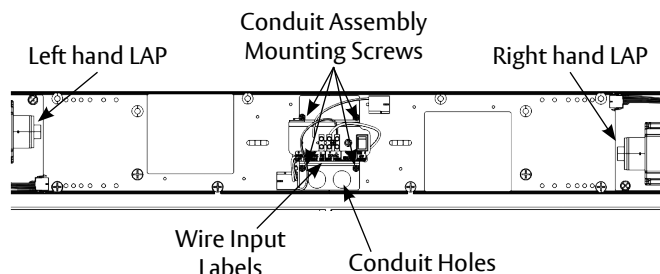

Figure 13

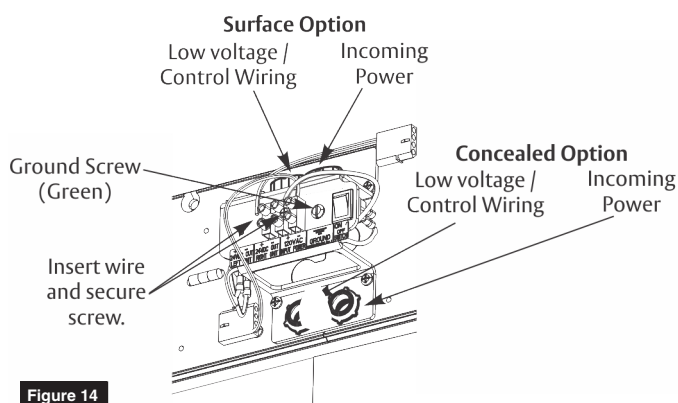

Figure 14



D. Install Power Module Sub-assemblies.

1. Using three (3) #8-32 x 5/16" Phillips screws per assembly, secure power module sub-assemblies to backplate at location marked on backplates. (Figure 15)

NOTE: Orient assemblies so LCD screens on inverters are toward corresponding closer assemblies. (Figure 15)

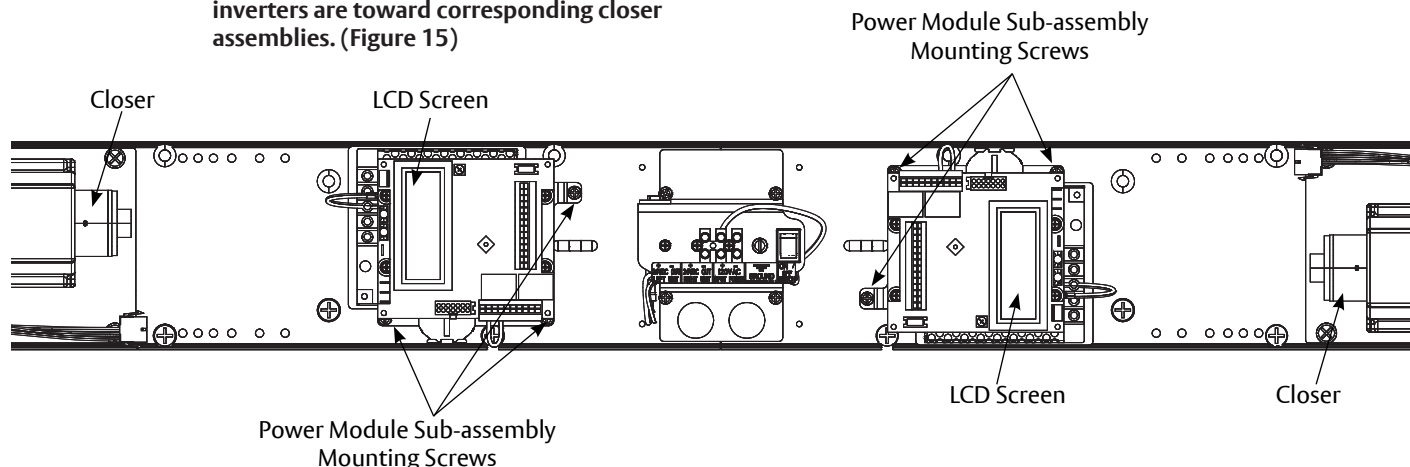

Figure 15 Wiring Removed From View

Install Operator

E. Connect Power Module Sub-assemblies to LAPS.

1. Attach 10-pin black connectors between each power module sub-assembly and its operator LAP. (Figure 16)
2. Attach 3-pin white connectors between each power module sub-assembly and its operator LAP. (Figure 16)

NOTE: Connectors are keyed and only attach one way.

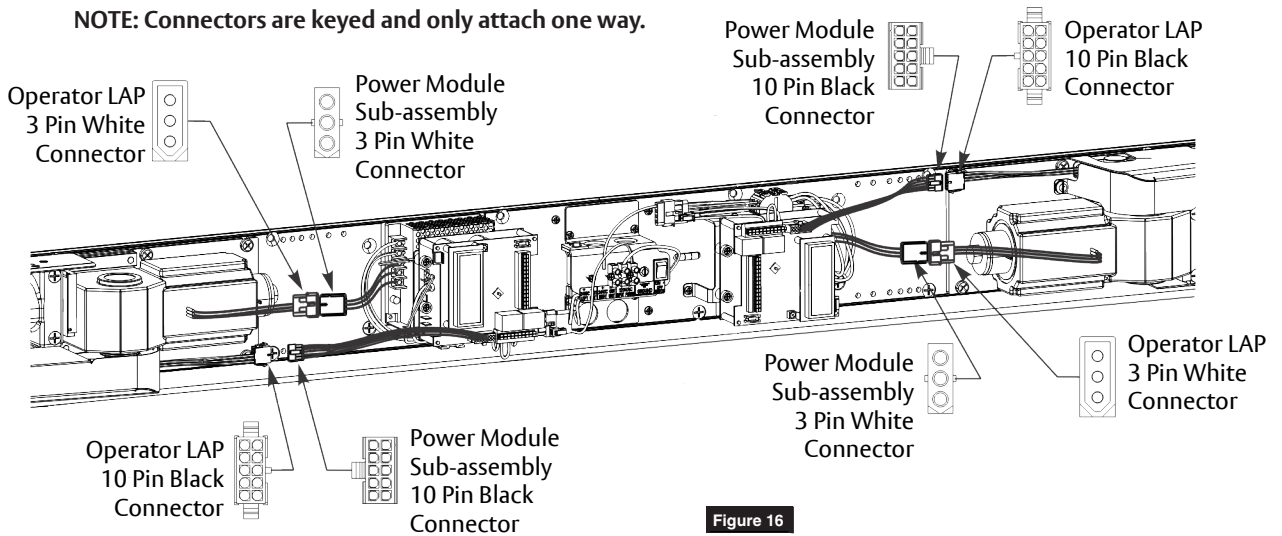

Figure 16

F. Install Union Assembly.

1. Orient union assembly so access door covering selector mode switches faces floor. (Figure 17)
2. Secure union assembly to backplate using four (4) #8-32 x 5/16" Phillips pan head screws. (Figure 17)
3. Connect 4-pin black square connector from power module sub-assembly to 4-pin black connector from union assembly for each operator. (Figure 18)

NOTE: Connectors are keyed and only assembly one way.

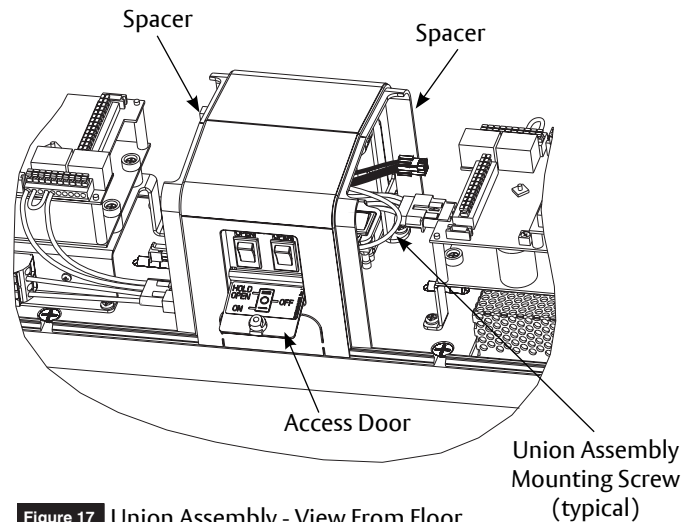

Figure 17 Union Assembly - View From Floor

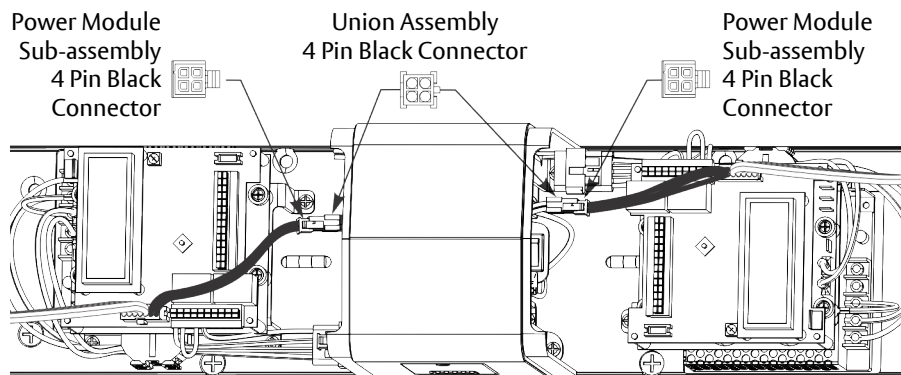
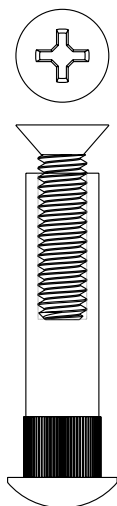

Figure 18

Install Adjusting Tubes and Shoes and Main Arms

A. Mount Adjusting Tubes and Shoes to doors.



1. Using previously prepared holes in doors, install two (2) 1/4-20 x 1-5/8" screws through each shoe and into sex bolts. (Figure 19)

NOTE: Orient shoe with short side of shoe toward hinge. (Figure 20)

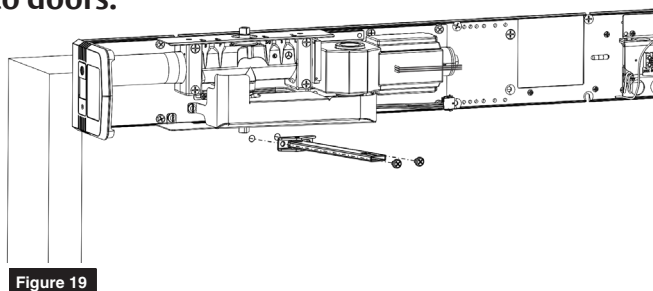

Figure 19

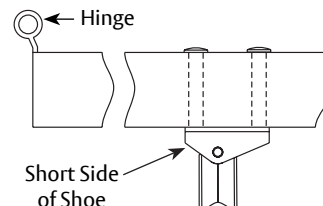
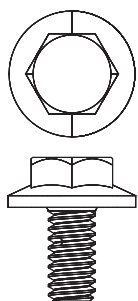

Figure 20 View from ceiling looking downward

B. Install Main Arms.



1. Open door of your choosing.
2. Slide main arm rod into adjusting tube. (Figure 21)
3. Place square of main arm onto closer pinion. (Figure 21)



NOTE: Pinion flat should be aligned as shown. (Figure 22)

4. Attach main arm to pinion with screw then tighten with 7/16" wrench. (Figure 21)
5. With door closed, rotate main arm away from hinge until adjusting tube is perpendicular (90 degrees) with door. (Figure 23)
6. While holding arm in position, secure rod to adjusting tube with forearm screw. (Figure 24)
7. Repeat on second door.

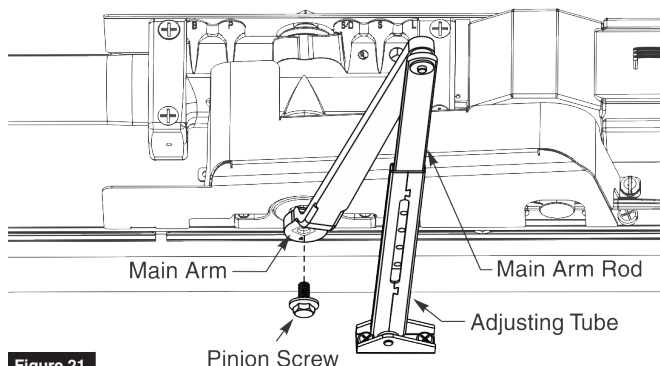

Figure 21

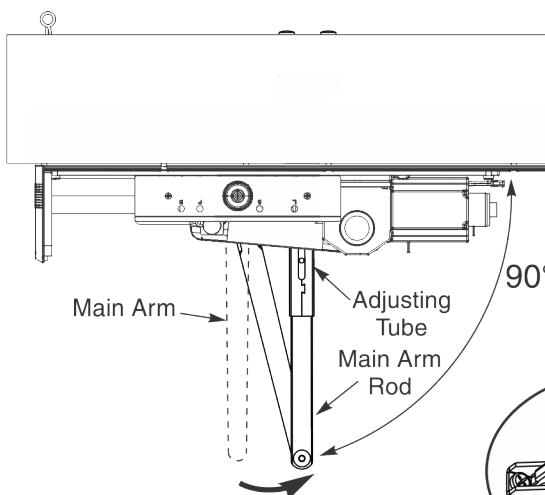

Figure 23 View from ceiling looking downward

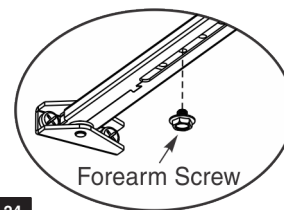

Figure 24

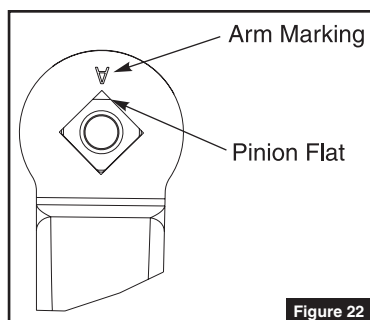

Figure 22

Adjustments

A. Adjust mechanical closer features on each operator.

NOTE:

- Make necessary mechanical adjustments so unit functions as a standard surface mounted door closer before adjusting spring force, applying power, adding accessories or making electrical/programming adjustments.
- Valve location S/D is not adjustable.

! Do not remove valves from closer. Hydraulic oil will escape.

1. Closing Speed Controls (Figure 25)
 - Valve "S" controls Sweep Range from full open to 10°.
 - Valve "L" controls Latch Range from 10° to closed.
2. Opening Cycle (Figure 25)
 - Valve "B" controls strength of cushioning in Backcheck Range.

! **NOTE: NEVER close Backcheck valve completely – it is not to provide a positive stop.**

- Valve "P" adjusts angle that backcheck is felt in open cycle. Factory preset is typically acceptable.

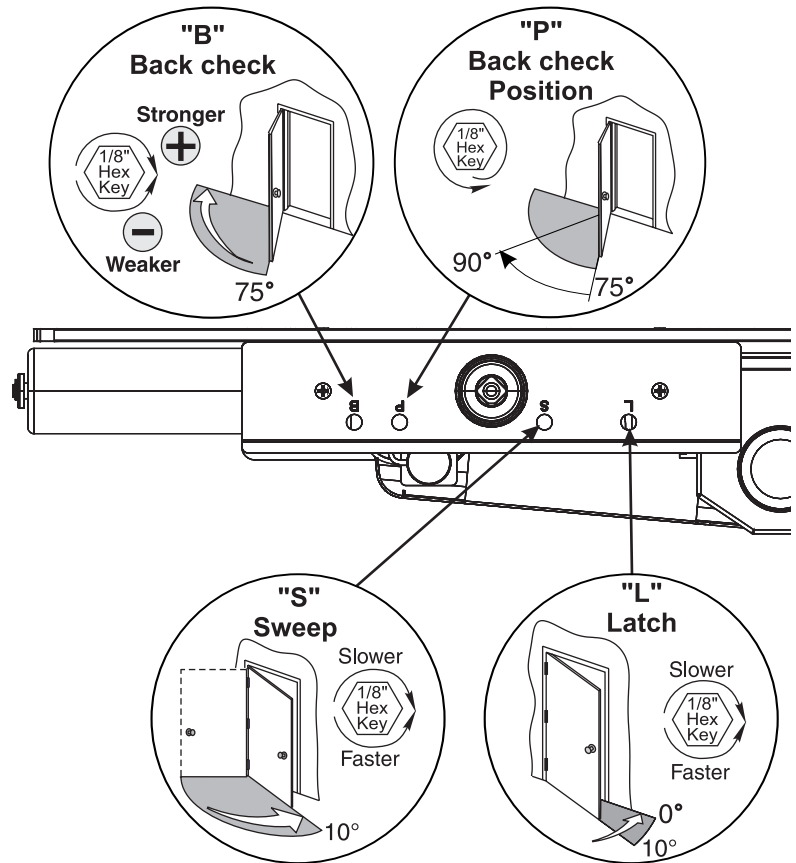

Figure 25 View of Left Hand operator from ceiling looking down

B. Adjust spring force on each operator.

NOTE:

- The amount of effort to manually open or close a door is called force and is controlled by the operator's closer spring.
- Make necessary mechanical adjustments described in "A" above.
- A closer set to ADA required 5 lbs opening force may not be strong enough to close door due to latching hardware, air pressure, or frame issues.

1. Using 11/16" wrench, turn nut in end of each closer body tube to desired force. (Figure 26)

NOTE: If spring adjustment nut is too close to end cap and wrench will not reach nut, remove Torx screw in end cap access door and slide door open. When finished, slide access door closed and reinsert #6 Torx flat head screw to secure door. (Figure 26)

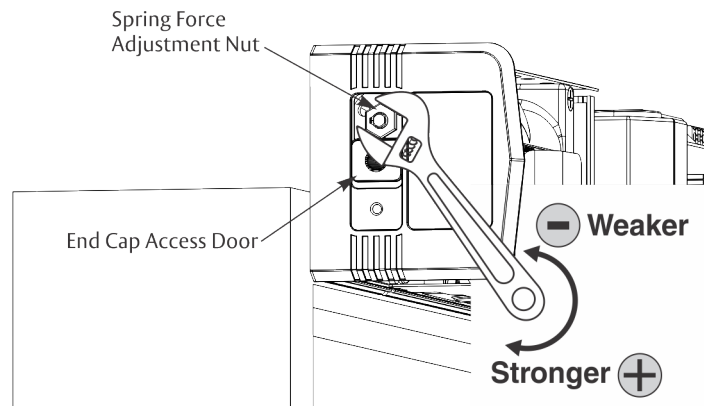

Figure 26 View of Left Hand operator

Power Operators

1. Open door on union assembly and place each selector mode switch in 'OFF' position. (Figure 27)
2. Turn On/Off switch to 'OFF' position on conduit assembly. (Figure 27)
3. Turn on building power.
4. Turn On/Off switch to 'ON' position on conduit assembly. See page 17 for controller adjustment options.
 - To scroll through menu items, push up or down on joystick. (Figure 27)
 - To change setting of a menu item, when cursor is on that item, push joystick left/right to increase/decrease value.

NOTE: Values will auto-save 3 seconds after adjustments.

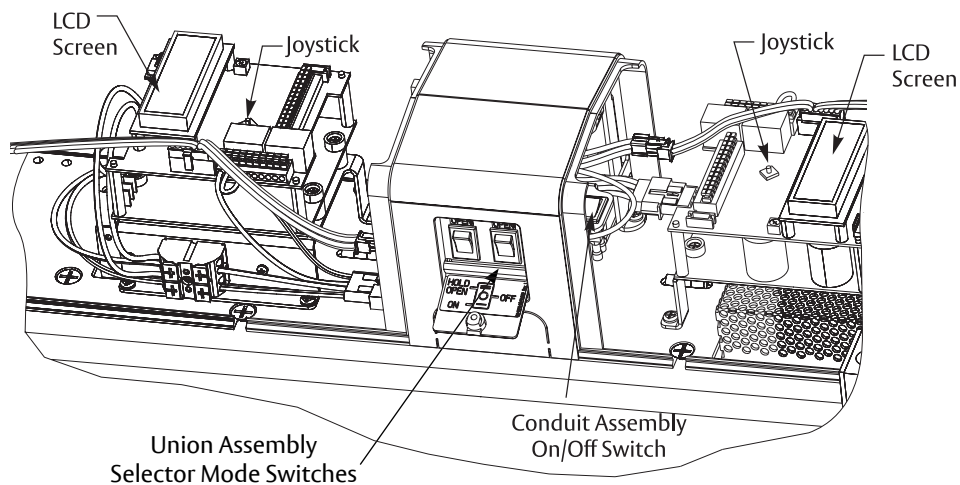

Figure 27 View From Floor

5. Set 'HOME' procedure for both doors.
 - With door closed and union assembly selector mode switch in "OFF" position, use joystick to scroll down menu on LCD screen to "Home".
 - Push in on joystick to activate menu feature. Display changes to "Set Close Limit".
 - Push in on joystick again, while door is still closed, to set Home or closed position (Figure 28). Display changes to "Set Open Limit".
 - Open door to desired open position (Figure 28) and push in on joystick again. Display changes to "Closing to Home".
 - Allow door to fully close again (Figure 28). Display changes to "Home".

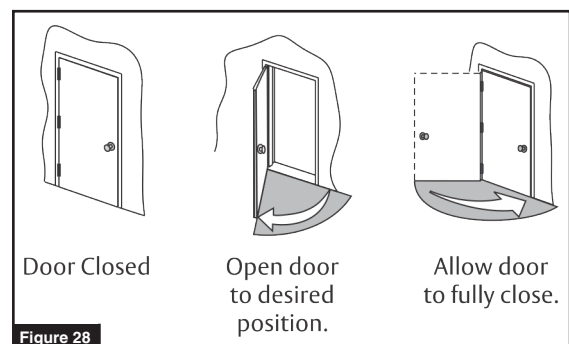

Figure 28

NOTE: Values will auto-save.

Sync Operators

1. Determine which door will be Master.
2. Run Sync Cable between operators. (Figure 29)
 - Attach end of Sync Cable marked “M” to 4-pin connector on top of inverter board on unit selected as Master Door.
 - Attach other end of Sync Cable marked “F” to 4-pin connector on top of inverter board selected as Follower Door.

NOTE: Connectors are keyed and only attach one way.

3. To set up inverter for Master - Follower functionality:

Master Unit:

- go to Page 2 on inverter screen
- scroll down to Single
- increase to Dbl:Master or *Dbl:MasterCoord

Follower Unit:

- go to Page 2 on inverter screen
- scroll down to Single
- increase to Dbl:Follower

***NOTE: Dbl:MasterCoord to be used when astragal or similar is attached to Master door or as a replacement for a mechanical door coordinator. Once set, Master**

door will open slightly before Follower door during opening cycle. Upon closing, if Master door reaches a set door opening position (MasterStopOffset) and Follower door has not reached full closed position, Master door will stop and wait for Follower door to reach fully closed and then close. The point at which Master door stops (MasterStopOffset) is adjustable.

***NOTE: If Dbl:MasterCoord is used and Follower door is opened manually, Master door will automatically open to MasterStopOffset position until Follower door has reached fully closed position and then close.**

4. Make necessary adjustments to Master Door inverter only, add activation to Master Door inverter only, and add required accessories to each door.

NOTE: Settings will automatically transfer over to Follower Door inverter.

5. Place both selector mode switches of union assembly in ‘ON’ position for activation by push plate, RF button, or other activation devices. Place switches in ‘H/O’ for continuous hold open. (Figure 29)
6. Secure union assembly door with #4 Phillips screw.

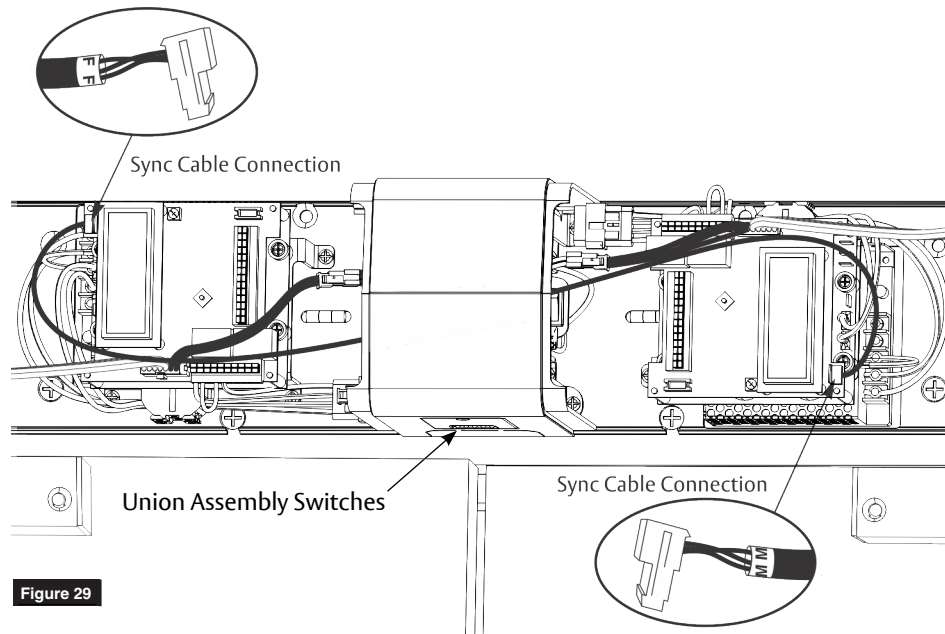

Figure 29

You’ve now installed the D6021 or D6031 PUSH SIDE Low Energy Operator.

Continue with Electrical Instructions to customize the installation.

Attach Covers to finalize installation

1. Align cut-outs in each cover to corresponding pinion shafts. (Figure 30)
2. Slide covers onto units using end caps and union spacers as guides.

NOTE: Verify all wiring and sheet metal guards are inside cover.

3. Snap covers securely to backplates. Pull on covers to verify they are secure.

NOTE: If cover will not securely snap onto backplate, verify backplate is not warped or twisted. Additional support or shimming may be required. See Sections A & B under Prepare Frame and Door.

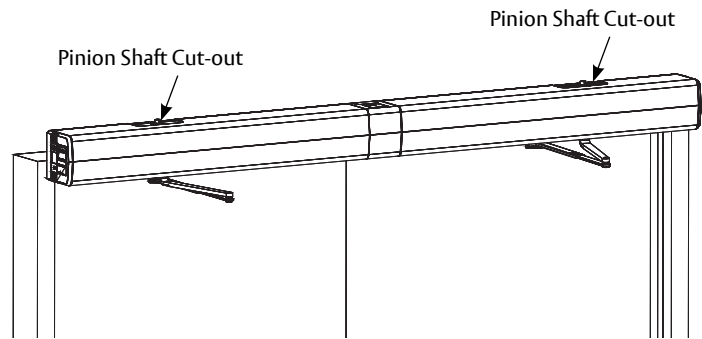

Figure 30



WARNING: Make sure no wiring is loose or can be caught by cover when it is snapped into place.

General Electrical Information

- Power inputs at power input connection and power output contacts must be made with copper wire only.
- Maximum wire size:
12 AWG at power input connection
14 AWG at all other terminals.
- Power input at terminals LINE and NEUTRAL must be 120VAC at 60 Hz (+10%, -15%).
- Maximum current draw from auxiliary devices is 1.3 amps.
- All wiring and connections use standard wiring practice conforming with local wiring codes.
- **Labeled fire or smoke barrier door assemblies require 120VAC 60Hz power input be supplied through normally closed alarm contacts of the alarm system / alarm panel.**

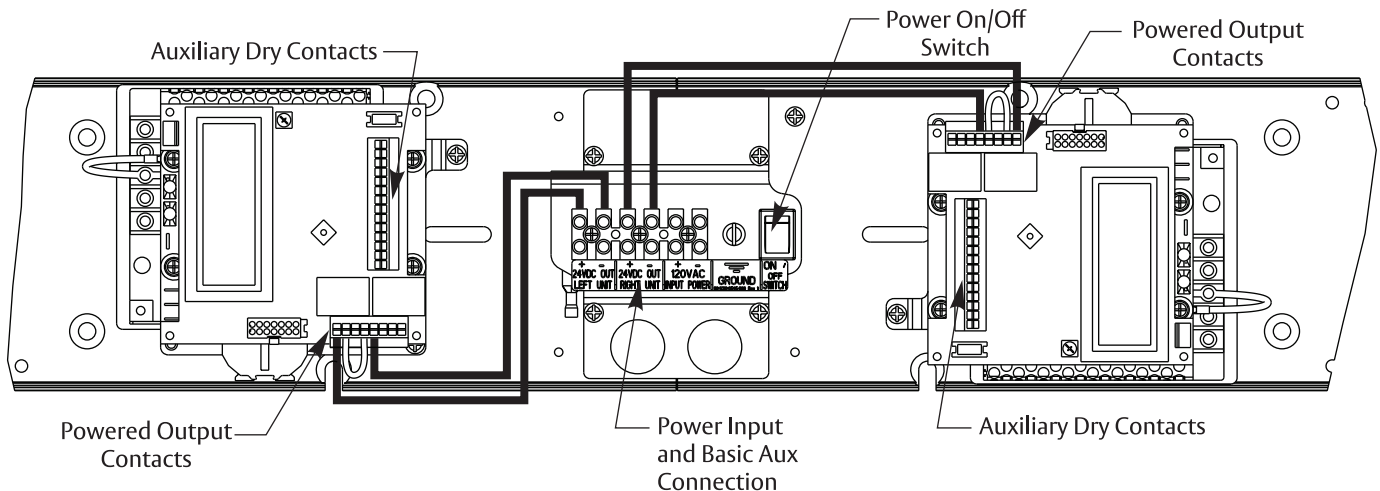

Factory Pre-Wiring of Connections and Incoming Wiring

To connect wiring:

For Incoming 120VAC and 24VDC for accessories

1. For 20 - 10 AWG wire
2. Strip end of wire 1/4 inch
3. Insert wire into appropriate position as shown and use flat head screw driver to secure

For Low Voltage / Dry Contacts on Inverter

1. For 24 - 16AWG wire
2. Strip end of wire 3/8 inch
3. Use flat blade screw driver to push down on white button above desired location, insert wire, release button. Pull on wire to confirm installed properly.

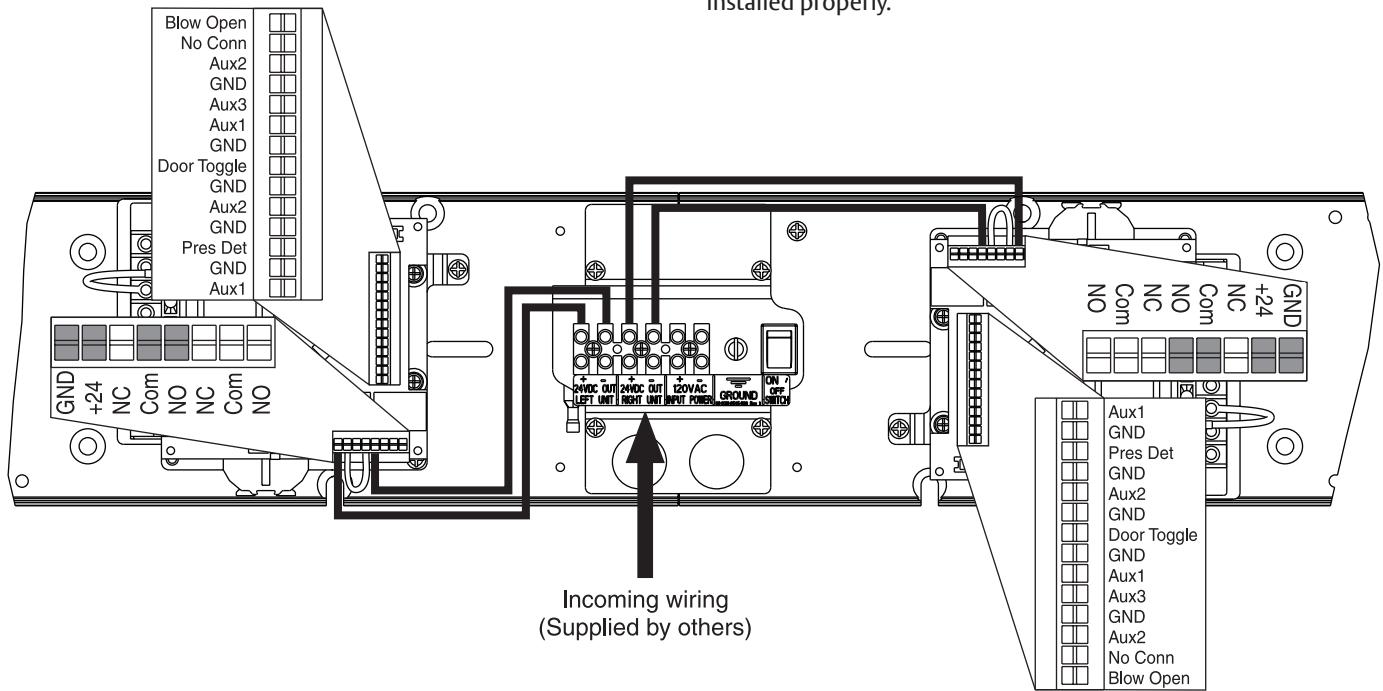

Controller Error Codes

Error Code	Description
Short Circuit	A short was sensed on the motor outputs
Temperature Trip	Power module reached 200°F or greater (too much load in too hot ambient condition)
Over Voltage	Line Voltage has reached 145VAC or greater
Under Voltage	Line Voltage has dropped below 80VAC
Aux 1 Stuck	Activation device connected to Aux 1 is sending constant signal
Aux 2 Stuck	Activation device connected to Aux 2 is sending constant signal
Aux 3 Stuck	Activation device connected to Aux 3 is sending constant signal
Comm Error	No communication between top and bottom controller boards. Boards not functioning properly
Presence Detect	Device connected to Presence Detect and was activated
Drive Disabled	Selector mode switch on end cap closest to latch is in "OFF" position

Controller Interface Description

Screen 1	Adjustments	Default	Description
Mount:	Push or Pull	Push	Side of opening operator is mounted on
Hold Open:	0 - 30 sec in 1 sec increments	4s	Amount of time door will stay in full open position after an activation
Open Delay (previously Start Delay):	0 - 10 sec in 1 sec increments	0s	Time before operator begins to open door. This is to allow accessories time to function and not hinder the opening of the door.
Latch Rtrct:	OFF, 3 - 45 sec in 5 sec increments	OFF	Amount of time power is supplied to a latch retraction device.
Home:	see Setting Open Position	-	Used to set the Home position and the Fully Open position of the door.
Vestibule:	OFF, 5 - 30 sec in 5 sec increments	OFF	Amount of delay for opening 2nd vestibule door
Push:	OFF or PushNGo	OFF	Turn on or off Push N Go feature. If On, a slight push or pull of the door starts it automatically opening.
Open Speed:	0 - 100% in 1% increments	120	How fast the door opens to the full open position.
Close Speed:	0 - 100% in 1% increments	80	How fast the motor returns to the home position. As Latch and Sweep on the closer are adjusted, adjustments may be needed for Close Speed to assure closer is not trying to backdrive the motor.
Errors:	not adjustable	-	Error code seen by controller. See Page 16 for Controller Error Codes.
Screen 2	Adjustments	Default	Description
Door Feedback:	not adjustable	-	General feedback. Includes Door State, Door Position, Motor Position, Open Limit, Close Limit.
Drive Feedback:	not adjustable	-	General feedback. Includes Bus Voltage, Bus Current, Frequency.
Usage:	not adjustable	-	General feedback. Includes Open Time, Close Time, Days, Cycles, Firmware Rev.
Single:	Single Door, Dble:Follow, Dble:Master, Dble:Mast Coord	Single	Set on Single for a single, stand alone door. Dble:Follow for Follower door on pair of doors. Dble:Master for Master door on a pair of doors. Dble:Mast Coord for Master door on a pair of doors when door coordination is needed.
MastStopOffset:	0-500	180	Adjustable point where Master Coord door will stop and wait for Follower door to fully close so Follower does not contact astragal attached to Master Coord door.
PDET Option:	On, Off	Off	On or Off for 585 Presence Detector
DT:	Standard, SS1:Stall, SS1:Return Open, SS1:Stall / Open	Stnd	Standard is Door Toggle. SS1 is for use of a Closing side door presence detector. SS1:Stall - door stalls when obstruction is detected; SS1:Return Open - door reopens when obstruction is detected; SS1:Stall/Open - door stalls when obstruction is detected and then reopens when obstruction is removed.
A2:	Standard, SS2:Stall, SS2:Return Home, SS2:Stall / Home	Stnd	Standard is Activation mode - just like A1 activation. SS2 is for use of an Opening side door presence detector. SS2:Stall - door stalls when obstruction is detected; SS2:Return Home - door closes to home when obstruction is detected; SS2:Stall/Home - door stalls when obstruction is detected and then returns home when obstruction is removed.
Rly2:	Alarm, Activation, On Opened, On Closed	Alarm	How Relay 2 is used: Alarm - used with above Alarm Delay; Activation - acts as an additional NO/NC contact; On Opened - relay trips (closed contacts) when door is in opened position; On Closed - relay trips (closed contacts) when door reaches the fully closed position.
Alarm Delay:	OFF, 30 sec, 60 sec	OFF	Used only for alarm accessories
Slow Speed:	0 - 100% in 1% increments	55	Speed up or slow down door during last few degrees of opening.
Hold Speed:	0 - 100% in 1% increments	55	Increase or decrease hold open force (when in "ON" position only, not "H/O") to compensate for spring force, wind conditions, etc.
Obst Delay:	0 - 5 sec in 1 sec increments	3s	Obstruction Delay: the amount of time the operator will push against an obstruction before closing if during an opening cycle or reopening and trying to close again if during a clocking cycle.

Basic Double Door Wiring Diagrams Using Factory Pre-Wired Connection

Standard Function with Switches

- For Master/Follow or Master-Coord/Follow only (Sync Cable must be used to connect inverters.)
- Doors are normally closed.
- Activating either switch will open both doors. Door will close after hold open time delay has expired.

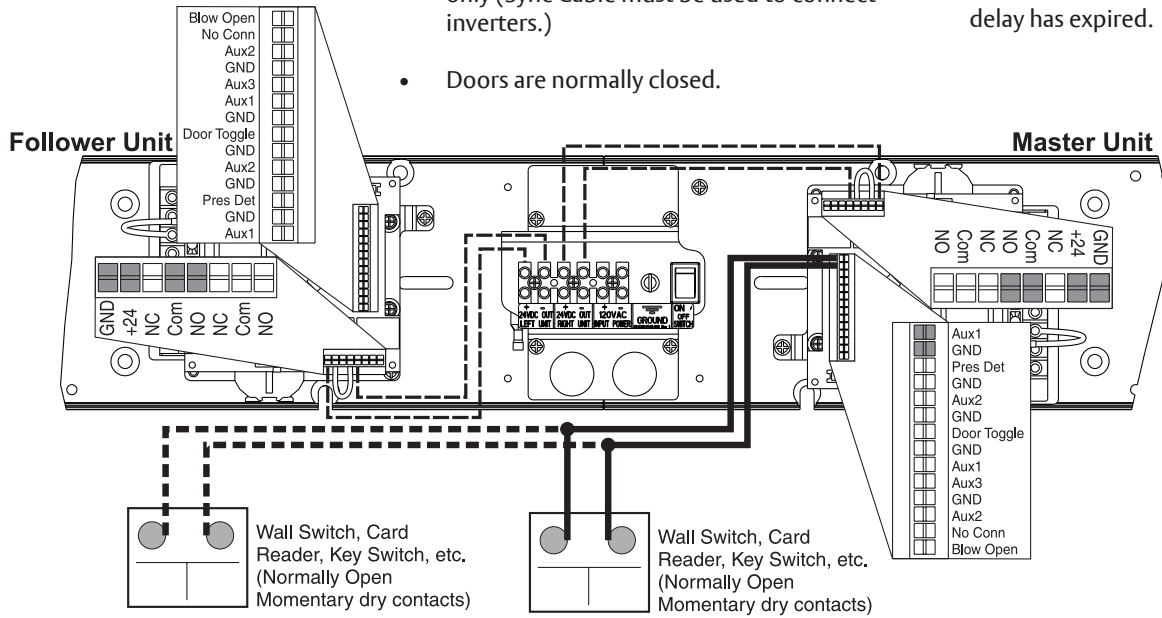

Fail Secure Electric Strike 24VDC Wiring

- For Master/Follow or Master-Coord/Follow only (Sync Cable must be used to connect inverters.)
- Doors are normally closed and latched.
- Activating switch will unlock electric strike and door will automatically open. Door will close after hold open time delay has expired.
- Door will remain locked during power failure.

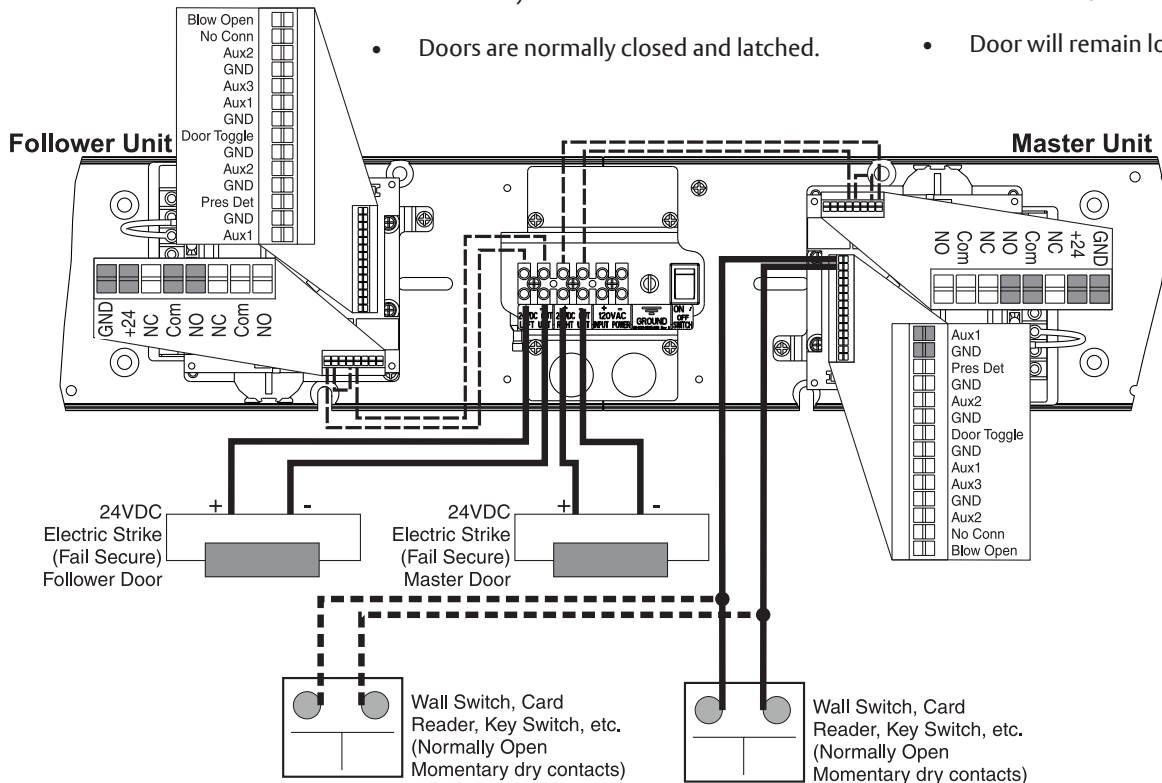

Double Door Fail Safe Electric Strike or Electromagnetic Lock 24VDC Wiring

Change Factory Pre-Wiring to Illustration Below (move NO to NC)

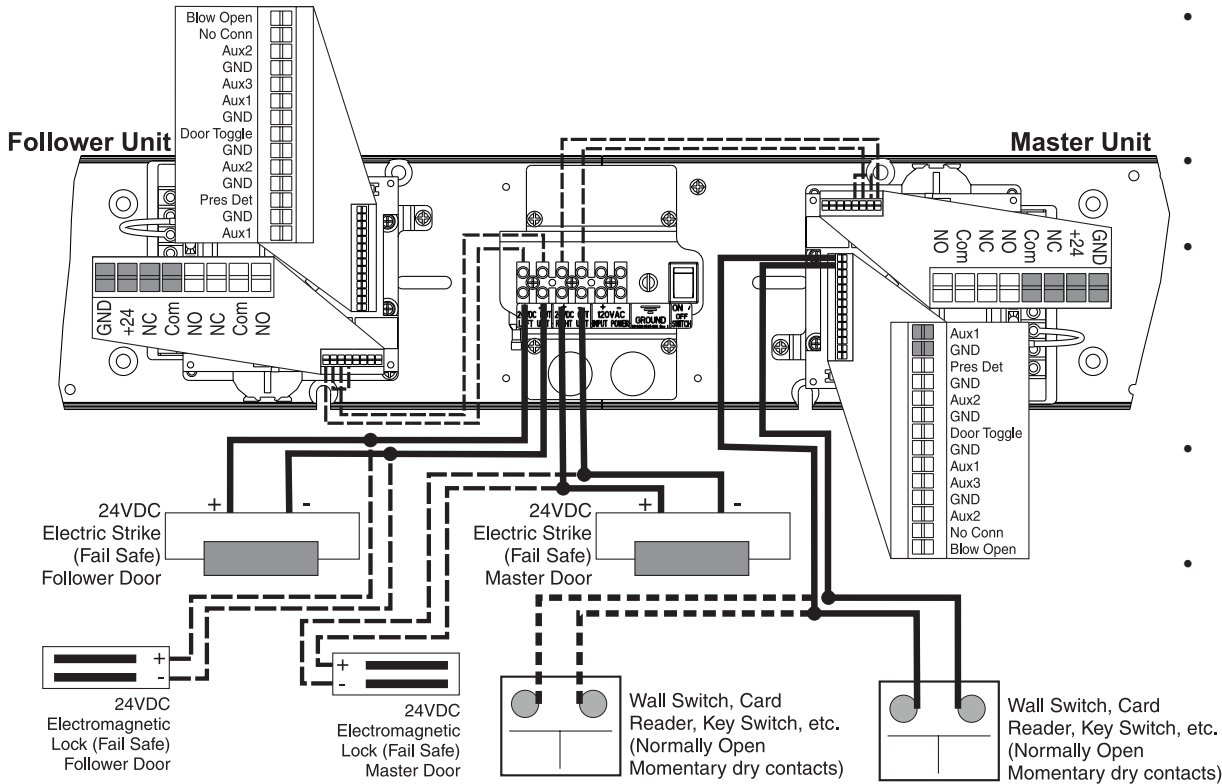

- For Master/Follow or Master-Coord/Follow only (Sync Cable must be used to connect inverters.)
- Doors are normally closed and latched.
- Activating switch will unlock electric strike or mag lock and door will automatically open. Door will close after hold open time delay has expired.
- Door will remain unlocked during power failure.
- Current draw at Power Outputs not to exceed 1.3 amps.

Double Door 24VDC Electric Exit Device Wiring

Factory Pre-Wiring in Illustration is for this functionality

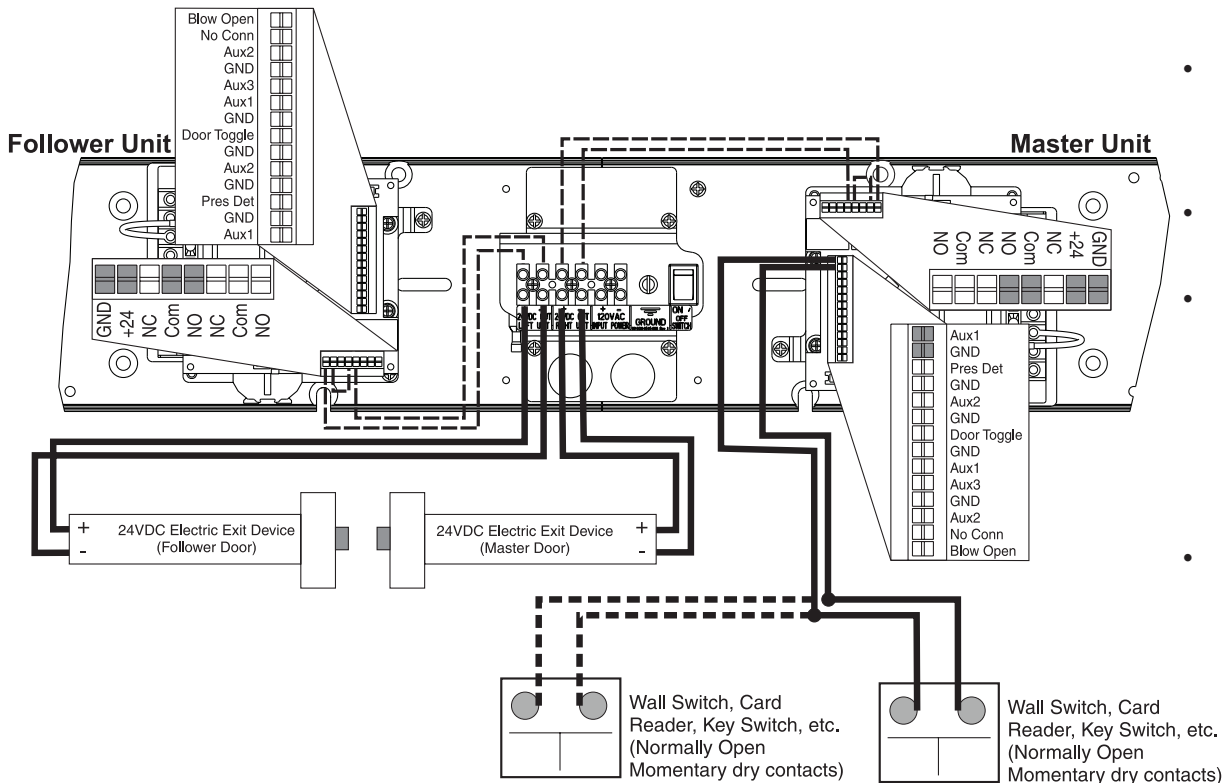

- For Master/Follow or Master-Coord/Follow only (Sync Cable must be used to connect inverters.)
- Doors are normally closed and latched.
- Activating switch will energize exit device and door will automatically open. Exit device will stay energized based on Latch Rtrct setting. Door will close after hold open time delay has expired.
- Current draw at Power Outputs not to exceed 1.3 amps.

Double Door Electric Dogging Exit Device Wiring

Change Factory Pre-Wiring to Illustration Below (move NO to +24)

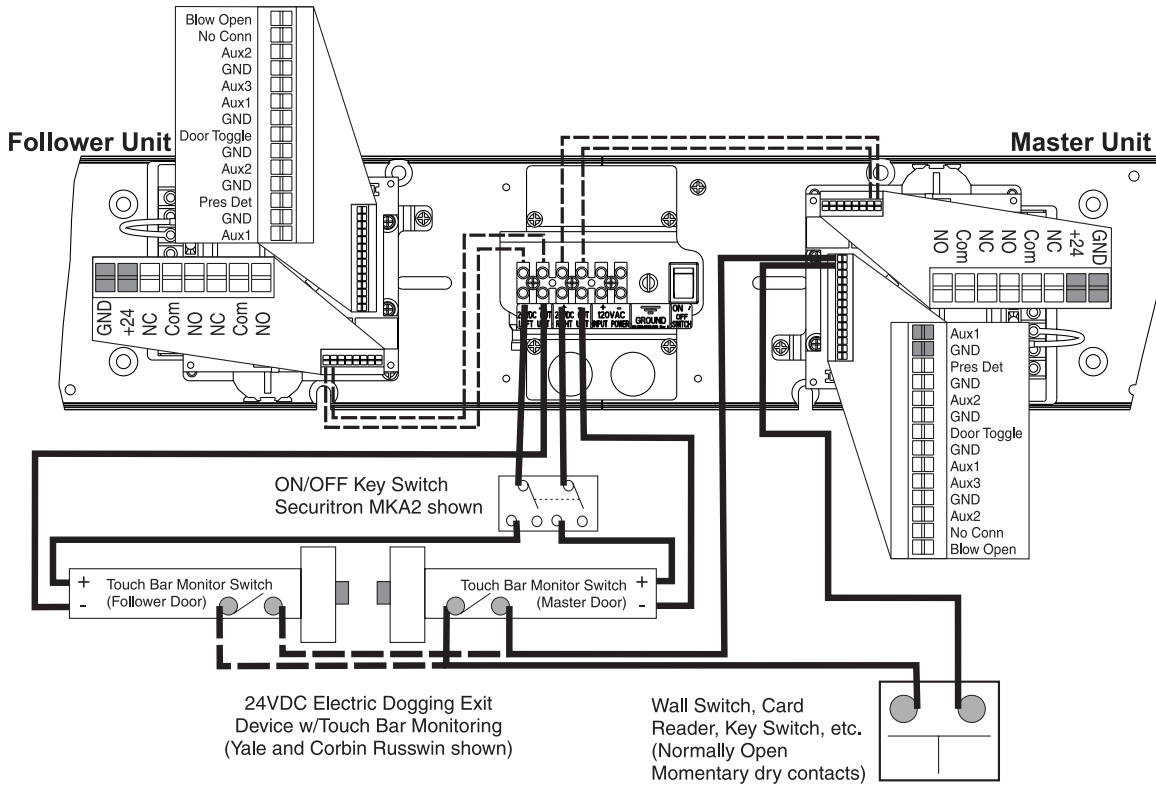

- For Master/Follow or Master-Coord/Follow only (Sync Cable must be used to connect inverters.)
- Doors are normally closed and latched.
- Turning key switch ON will apply power to exit device.
- First depression on device touchpad will electrically dog device for push/pull operation.
- Door will now open automatically when wall switch is depressed.
- Device will re-latch during a power failure or when key switch is turned off.
- Exit device allows egress at all times. Exit device allows egress during power failures.
- Current draw at Power Outputs not to exceed 1.3 amps.

Double Door Hard Wired Executive Function Wiring

Factory Pre-Wiring Not Required to Change

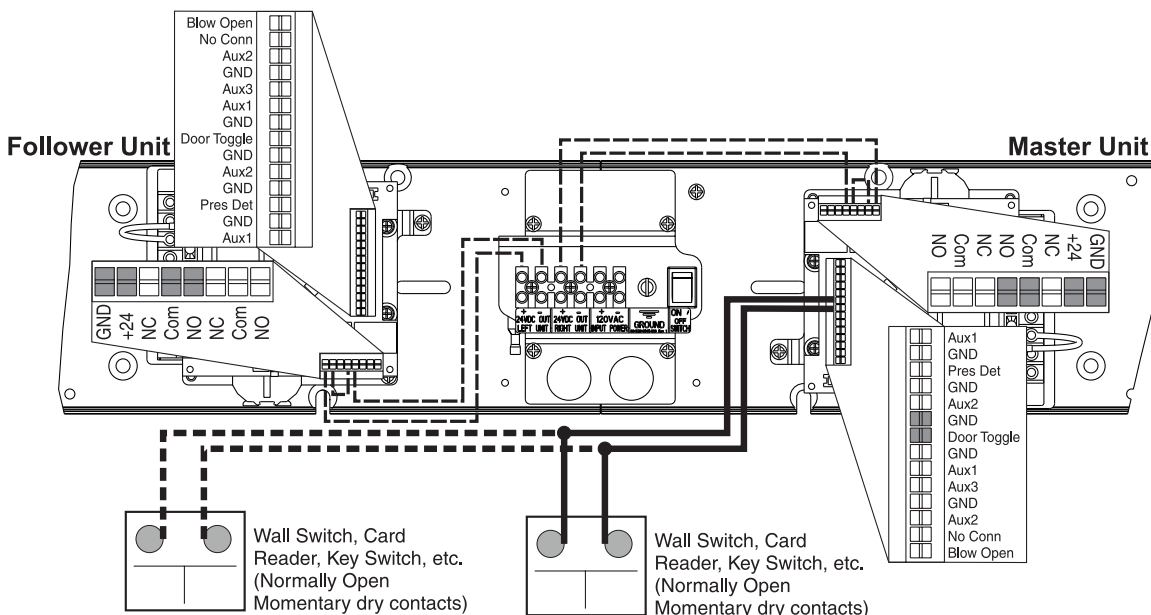

- For Master/Follow or Master-Coord/Follow only (Sync Cable must be used to connect inverters.)
- Doors are normally closed.
- Activating switch will open door.
- Door will remain in indefinite hold open until activating switch is activated a second time causing door to close.

Double Door Radio Frequency Standard Function Wiring

If Installing in the Field, change Factory Pre-Wiring to Illustration Below (move NO to +24)

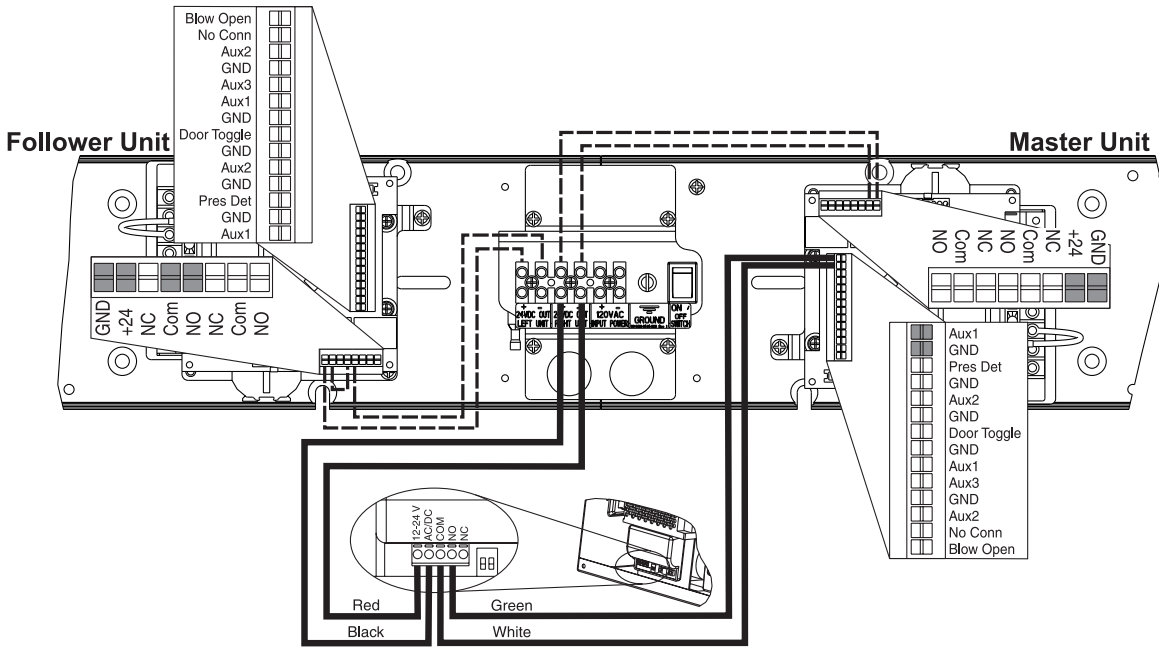

- For Master/Follow or Master-Coord/Follow only (Sync Cable must be used to connect inverters.)
- Doors are normally closed.
- Activating wireless switch or hand held wireless transmitter will open door.
- Door will close after hold open time delay has elapsed.
- Current draw at Power Outputs not to exceed 1.3 amps.

Double Door Radio Frequency Executive Function Wiring

If Installing in the Field, change Factory Pre-Wiring to Illustration Below (move NO to +24)

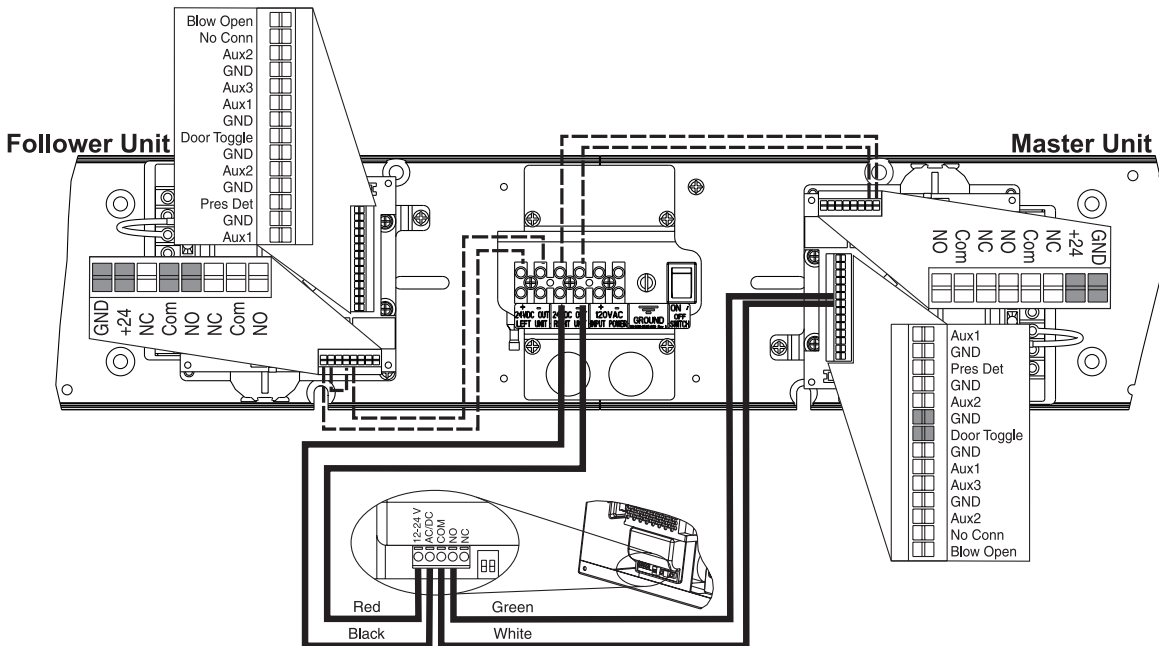

- For Master/Follow or Master-Coord/Follow only (Sync Cable must be used to connect inverters.) Doors are normally closed and latched.
- Activating wireless switch or hand held wireless transmitter will open door.
- Door will remain in indefinite hold open until wireless switch or hand held transmitter is activated a second time causing door to close.
- Current draw at Power Outputs not to exceed 1.3 amps.

Double Door Vestibule Function Wiring Using Factory Pre-Wiring

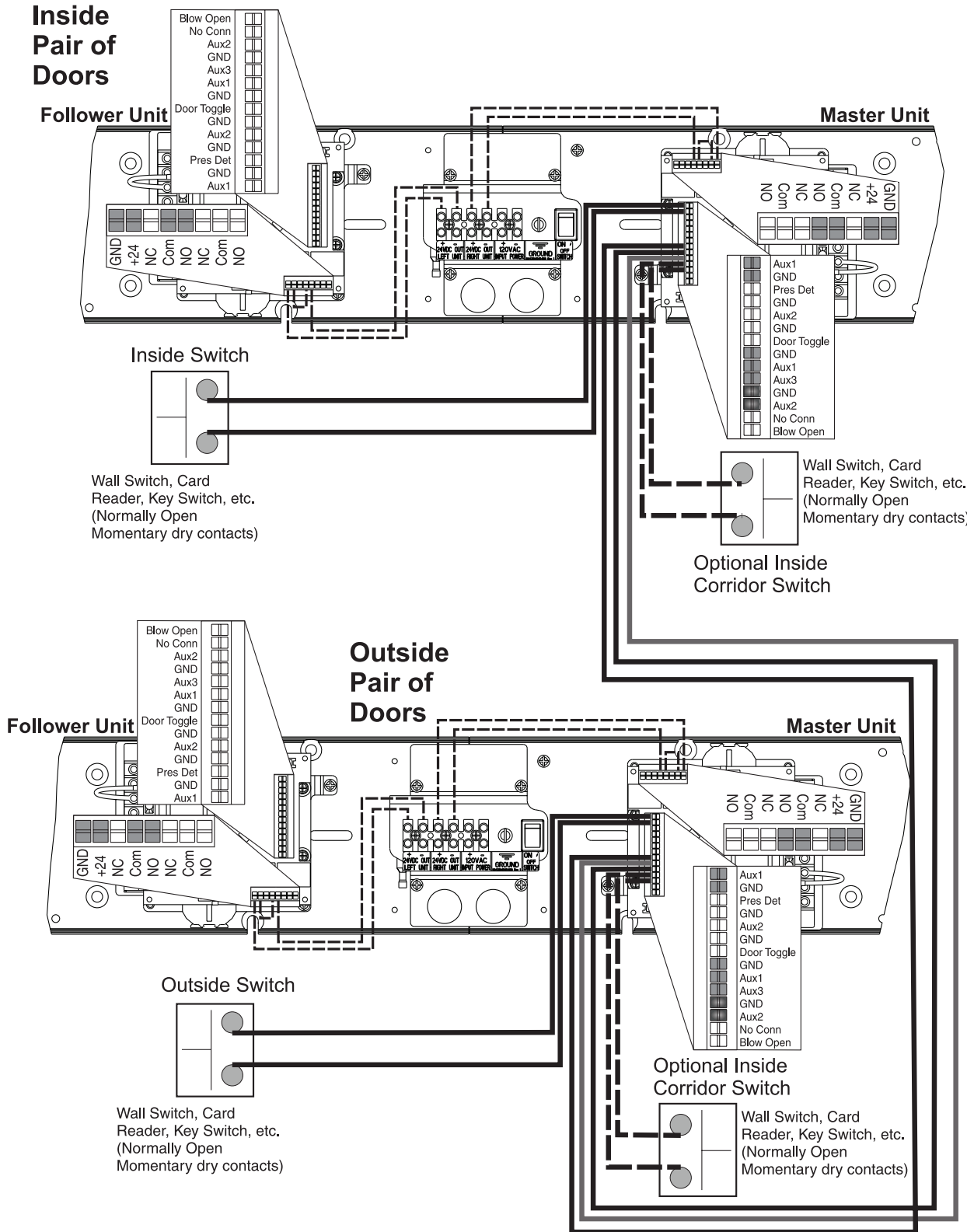

- For Master/Follow or Master-Coord/Follow only (Sync Cable must be used to connect inverters.)
- Doors are normally closed and latched.
- Activating outside door switch will open outside door. After vestibule time delay has elapsed, a signal will be sent to inside door which will open. Activating inside door switch will open inside door. After vestibule time delay has elapsed, a signal will be sent to outside door which will open. Both doors will close when hold open time delay has elapsed.
- Activating optional inside door switch located within corridor will open inside door only. This door will re-close after hold open delay has elapsed.
- Activating optional outside door switch located within corridor will open outside door only. This door will re-close after hold open delay has elapsed.

433MHz Receiver User's Guide

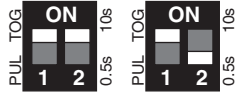

In Toggle Setting (1-ON), Hold Time is inactive. Either setting for #2 dip switch will have same result.

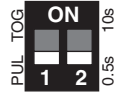

0.5 second Pulse Setting

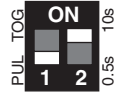

10 second Pulse Setting

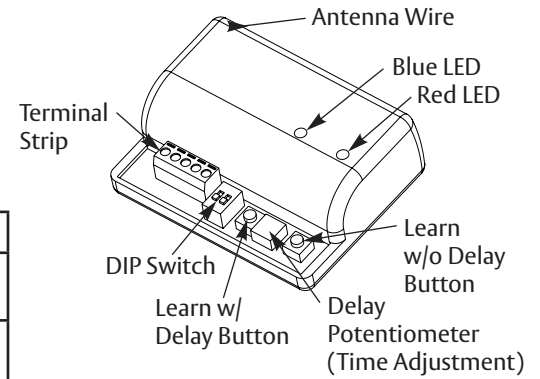

#1	Description	Function
OFF	Pulse Relay	Press transmitter once and relay will be active momentarily.
ON	Toggle Relay	Press transmitter once and relay output is active indefinitely. Press it again and relay will de-energize indefinitely.

#2	Description	Function
OFF	0.5s Hold Time	Relay will remain active 0.5 sec after loss of activation.
ON	10s Hold Time	Relay will remain active 10 sec after loss of activation.

NOTE:

- Always stop pedestrian traffic through doorway when performing tests that may result in unexpected reactions by door.
- Ensure compliance with all applicable safety standards upon completion of installation.
- See diagrams on page 22 for wire colors.

Hand-Held Configuration

1. Set dip switches to receiver to desired activation cycle (dip switch 1 - Toggle or Pulse and dip switch 2 - 0.5s or 10s hold).
2. Press either Learn w/ Delay Button or Learn w/o Delay Button on receiver depending on activation requirements (if delay learn is selected, adjust potentiometer to counterclockwise limit, 0 second delay). Red LED on receiver will flash. After learn cycle is complete, adjust potentiometer to desired delay time (0 - 30 sec).
3. Depress transmitter button repeatedly until Blue LED on receiver illuminates (indicating reception of signal from transmitter).
NOTE: Repeat Steps 2 - 3 to program additional transmitters.
4. To test system, depress transmitter button (Red LED on Transmitter will illuminate) and observe that Blue LED illuminates on receiver. This indicates that relay has been activated.

Push Plate Configuration

1. Before beginning, prepare installation of push plate.
2. Connect wires from transmitter to NO and COM contacts of push plate's switch.
3. Follow Steps 1 - 4 (Hand-Held Configuration); depress push plate to activate transmitter.
4. Attach transmitter to inside of electrical box and complete installation.

Removing Transmitter Code(s)

Single Transmitter Code:

- Press both Delay and No Delay Buttons simultaneously until Red LED flashes once (approximately 1 second).
- Press transmitter button twice within 10 seconds and transmitter code will be deleted.

All Transmitter Codes:

- Press and hold both Delay and No Delay Buttons simultaneously until Blue LED illuminates then release (approximately 10 seconds).

Troubleshooting	
Problem	Solution
LED on receiver is flickering - unable to program and/or won't work	Push plate stuck or faulty transmitter. Disconnect each push plate until LED goes out. If LED does not go out, remove each transmitter battery until it does. Replace appropriate transmitter.
Receiver intermittently doesn't receive transmitter(s) signal.	Extend receiver antenna wire only in multiples of 6-3/4" (171) Example: 6.75 x 4 = 27" (686) of extended antenna wire.

585 Presence Detector Wiring on Double Door Opening

- For Master/Follow or Master-Coord/Follow only (Sync Cable must be used to connect inverters.)
- Door is normally closed.
- Activating switch will open door.
- Door will close after hold open time delay has elapsed.
- If door is closed and 585 Presence Detector senses something in opening, door will not open.
- If door is at open position and 585 Presence Detector senses something in opening, door will not close.

NOTE: Presence Detector and/or sensors CANNOT be used to active opening cycle of door.

To activate presence detector functionality:

- On inverter, use up/down arrows to scroll to Page 1.
- Use left/right arrows to change to Page 2.
- Use up/down arrows to scroll to PDET Option.
- Use left/right arrows to change value from OFF to ON.
- Use instructions provided with 585 sensor to program and make any necessary adjustments to sensor.

585 Presence Detector mounted to / above frame (on double opening)

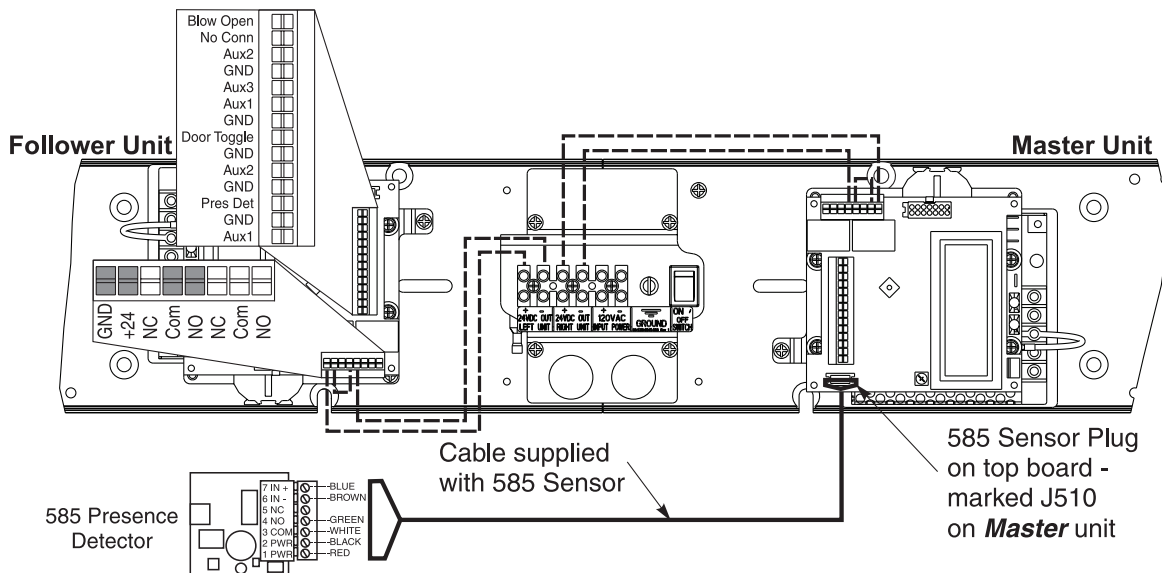
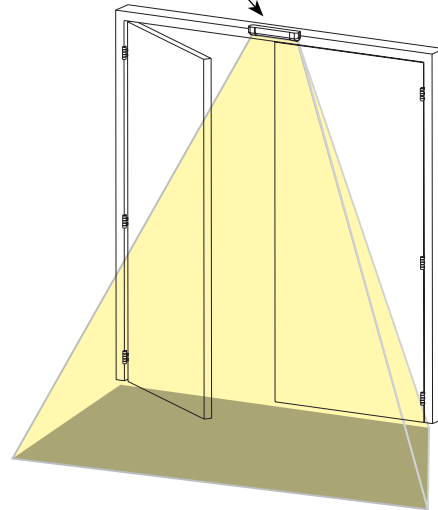

Door Mounted Presence Detector (596 Series) Wiring on Double Door Opening

- For Master/Follow or Master-Coord/Follow only (Sync Cable must be used to connect inverters.)
- Doors are normally closed.
- Activating switch will open door.
- Door will close after hold open time delay has elapsed.
- If using door mounted presence sensors:
 - For Closing cycle sensor (SS1), adjust DT on page 2 of controller screen. If DT is set to Standard, this is normal Door Toggle mode and will not work with Presence Sensor; set to Stall, door closing will stall until presence not sensed; set to Return Open, presence is sensed and door fully reopens; set to Stall/Open, presence is sensed and door will stall then reopen once presence not sensed.
 - For Opening cycle sensor (SS2), adjust A2 Option on page 2 of controller screen. If door is set to Standard, switch or other activation into A2 acts like A1. If A2 set to Stall, door will stop opening and stall until presence not sensed; set to Return Home, door will close back to Home position when presence is sensed; if set to Stall/Home, door will stall and return home once presence not sensed.

596 Presence Sensor mounted to opening side or closing side of door (on double opening)

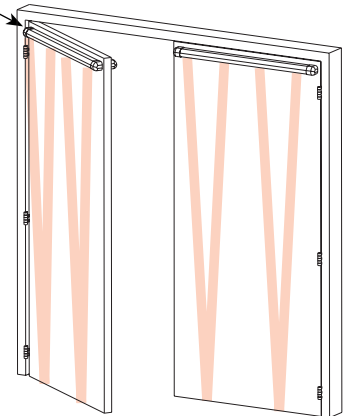

NOTE: Presence Detector and/or sensors CANNOT be used to active opening cycle of door.

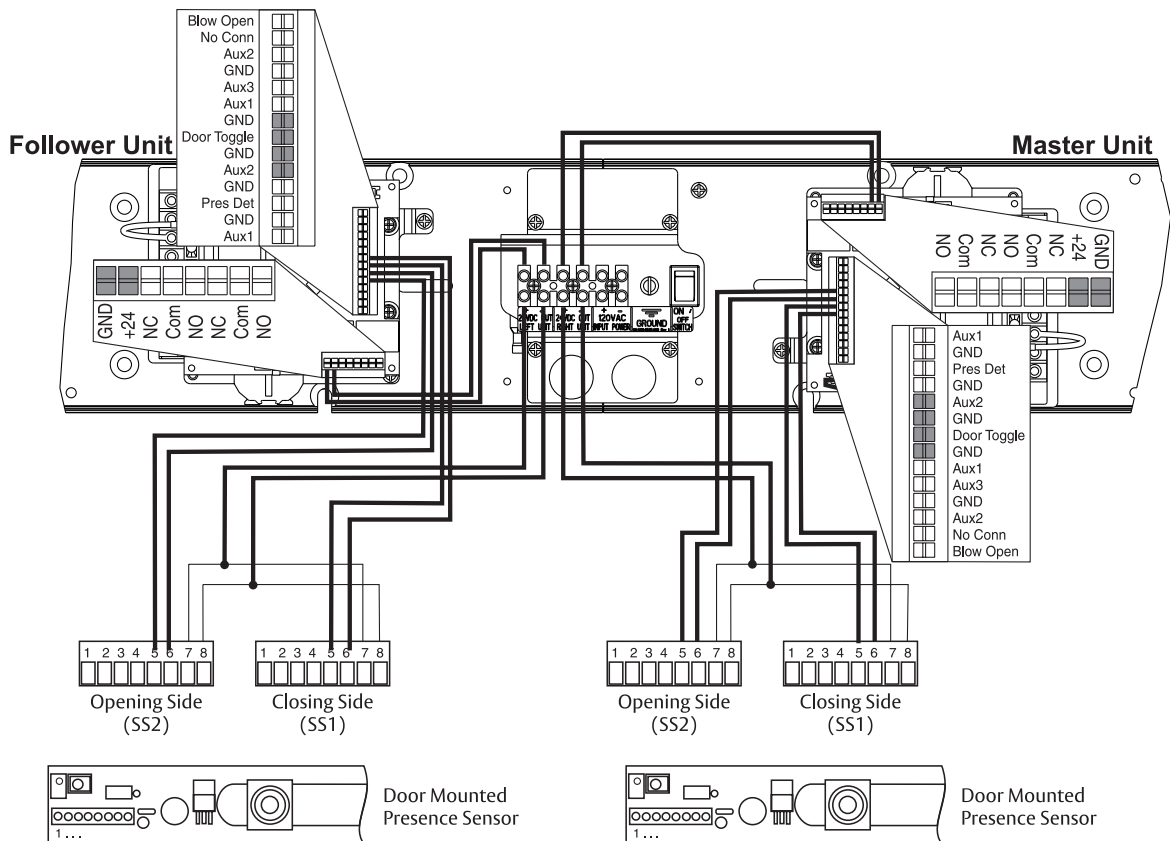

The ASSA ABLOY Group is the global leader in access solutions. Every day we help people feel safe, secure and experience a more open world.

Troubleshooting Guide

Problem	Solution
Door closing too fast	1) Adjust Latch and/or Sweep valves on closer clockwise OR 2) Decrease Closing Speed on controller (see page 12)
Door closing too slow	1) Adjust Latch and/or Sweep valves on closer counterclockwise OR 2) Increase Closing Speed on controller (see page 12)
Door does not open to desired location	1) Repeat Home process (see page 13), OR 2) Increase Obst Delay, OR 3) Adjust Backcheck valve on closer counterclockwise, OR 4) Decrease spring force on closer body (door must still close in event of power failure (see page 12), OR 5) Ensure shoe is properly oriented on door (see page 11)
Door does not reach fully opened position	1) Repeat Home process (see page 13), OR 2) Increase Obst Delay, OR 3) Adjust Backcheck valve on closer counterclockwise, OR 4) Decrease spring force on closer body (door must still close in event of power failure (see page 12), OR 5) Ensure shoe is properly oriented on door (see page 11)
Door opens and closes repeatedly	Change selector mode switch from H/O to On
Motor is driving in the wrong direction	Change Mount (Push / Pull) on controller, reset Home process (see page 13), and save values
When door reaches open position, door drifts toward closed position	Increase Hold Speed on controller (see page 17) until door stops drifting
When door reaches open position, door drifts further open	Decrease Hold Speed on controller (see page 17) until door stops drifting
When door reaches open position, door bounces	Decrease Slow Speed on controller (see page 17)
When signal is received, operator tries to open door before auxiliary components are unlatched / retracted	1) Confirm latch devices are getting proper power, 2) Confirm latch devices are receiving power long enough to fully retract - adjust Latch Retraction on controller (see page 17) as needed, 3) If latch device is not retracting fast enough, increase Start Delay on controller (see page 17) to assure latch device has had sufficient time to fully retract before operator starts opening door.
Error message says "Short Circuit"	Turn off power to unit. Check wiring for short / cut.
Error message says "Over Voltage"	Check incoming power - line voltage has exceeded 145VAC
Error message says "Under Voltage"	Check incoming power - line voltage has dropped below 80VAC
Error message says "Aux1, Aux 2, or Aux 3 Stuck"	Disconnect Aux 1, 2, or 3 inputs and confirm error message goes away. If so, make sure input device is not stuck (sending constant signal). Controller has a 3 minute protection limit.
Error message says "Comm Error"	Inverter must be replaced
Error message says "Presence Detect"	Unit has a presence detector attached and device has been activated
Error message says "Drive Disabled"	Selector mode switch is in the "Off" position
Cover will not snap onto backplate	1) Wire protruding from under cover 2) Backplate is twisted / not mounted properly. (see page 7)
Cover will not stay on operator	Cover extrusion has been stretched too wide and will not properly secure
When doors are closing Follower door hits astragal on Master door and will not fully close	1) Confirm door with astragal is set to Master-Coordinator 2) Adjust 'Master Stop' value to move position where Master door will 'stop' and wait for Follower door to fully close. Once Follower door has fully closed, Master door should then close.

Norton Technical Product Support:
Monroe, NC 28112 USA
Phone: 800.438.1951 ext: 6030
TechSupport.Norton@assaabloy.com
nortondoortcontrols.com

Norton is a brand associated with ASSA ABLOY Accessories and Door Controls Group, Inc., an ASSA ABLOY Group company. Copyright © 2019-2020, ASSA ABLOY Accessories and Door Controls Group, Inc. All rights reserved. Reproduction in whole or in part without the express written permission of ASSA ABLOY Accessories and Door Controls Group, Inc. is prohibited.

D6021 and D6031 Double Unit Series Template

Push Side Application ONLY

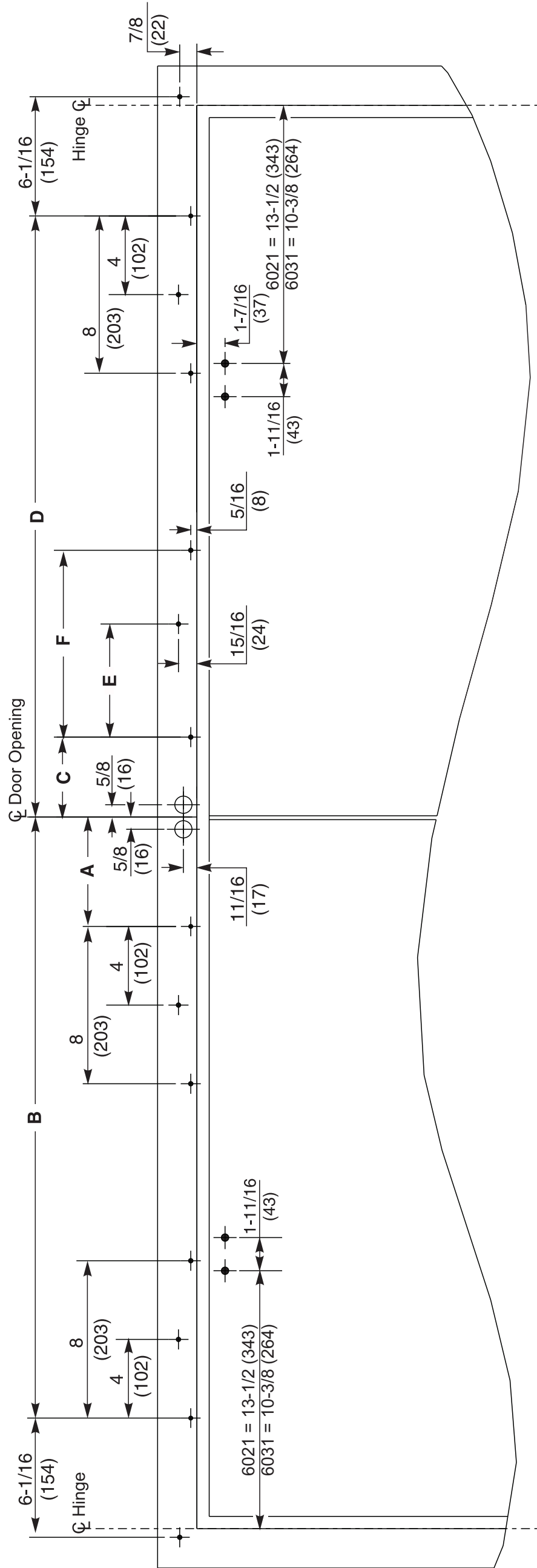

- Notes:
- Do not scale drawing.
 - Operator shown for push side double door application.
 - All dimensions are given in inches and millimeters.
 - Recommended thickness for reinforcements in hollow-metal doors and frames should provide a combined material thickness of .164 (4.2) MIN.
 - This template information based upon use of 5 (127) maximum width butt hinges or 3/4 (19) offset pivots.
 - D6021 reveal 6-7/8" (175) maximum and 110° of opening.
 - D6031 reveal 6-7/8" (175) maximum and 180° of opening.

Door Size	Dim A	Dim B	Dim C	Dim D	Dim E	Dim F
36	5-9/16 (141)	30-9/16 (776)	4-1/16 (103)	30-9/16 (776)	5-3/4 (146)	9-1/2 (241)
38	7-9/16 (192)	32-9/16 (827)	4-1/16 (103)	32-9/16 (827)	7-3/4 (197)	11-1/2 (292)
40	9-9/16 (243)	34-9/16 (878)	9-9/16 (243)	34-9/16 (878)	4 (102)	8 (203)
42	11-9/16 (294)	36-9/16 (929)	10-1/16 (256)	36-9/16 (929)	5-3/4 (146)	9-1/2 (241)
44	13-9/16 (344)	38-9/16 (979)	12-1/16 (306)	38-9/16 (979)	5-3/4 (146)	9-1/2 (241)
46	15-9/16 (395)	40-9/16 (1030)	14-1/16 (356)	40-9/16 (1017)	5-3/4 (146)	9-1/2 (241)
48	17-9/16 (446)	42-9/16 (1081)	16-1/16 (408)	42-9/16 (1081)	5-3/4 (146)	9-1/2 (241)

