

Installation Manual: PAD100-DIM Dual Input Module

NOTICE TO THE INSTALLER

This manual provides an overview and the installation instructions for the PAD100-DIM module. This module is only compatible with addressable fire systems that utilize the PAD Addressable Protocol.

All terminals are power limited and should be wired in accordance with the requirements of NFPA 70 (NEC) and NFPA 72 (National Fire Alarm Code). Failure to follow the wiring diagrams in the following pages will cause the system to not operate as intended. For further information, refer to the control panel installation instructions.

The module shall only be installed with listed control panels. Refer to the control panel installation manual for proper system operation.

1. Description

The PAD100-DIM uses one (1) SLC loop address when monitoring two (2) Class B circuits or one (1) Class A circuit. The module mounts on either an UL Listed 2-1/2" deep 2-gang box or 1-1/2" deep 4" square box. The PAD100-DIM is capable of monitoring two (2) separate Class B circuits making it ideal for monitoring sprinkler waterflow and valve tamper switches when they are located in the same proximity.

The PAD100-DIM includes one red LED to indicate the module's status. In normal condition, the LED flashes when the device is being polled by the control panel. When an input is activated, the LED will flash at a fast rate. If the LED blink has been disabled via the programming software, in a normal condition the LED of the device will be off. All other conditions remain the same.

2. Setting the Address

All PAD protocol detectors and modules require an address prior to connection to the panel's SLC loop. Each PAD device's address (*i.e., detector and/or module*) is set by changing the dip switches located on the device. PAD device addresses are comprised of a **seven (7) position dip switch** used to program each device with an address ranging from 1–127.

Figure 1. PAD Device Dip Switch Addresses Table (Addresses 1–127)

1	2	4	8	16	32	64	1	2	4	8	16	32	64	1	2	4	8	16	32	64	1	2	4	8	16	32	64	1	2	4	8	16	32	64
1							27							53							78					103								
2							28							54							79					104								
3							29							55							80					105								
4							30							56							81					106								
5							31							57							82					107								
6							32							58							83					108								
7							33							59							84					109								
8							34							60							85					110								
9							35							61							86					111								
10							36							62							87					112								
11							37							63							88					113								
12							38							64							89					114								
13							39							65							90					115								
14							40							66							91					116								
15							41							67							92					117								
16							42							68							93					118								
17							43							69							94					119								
18							44							70							95					120								
19							45							71							96					121								
20							46							72							97					122								
21							47							73							98					123								
22							48							74							99					124								
23							49							75							100					125								
24							50							76							101					126								
25							51							77							102					127								
26							52																											

Note: Each "gray" box indicates that the dip switch is "On," and each "white" box indicates "Off."

The examples shown below illustrate a PAD device's dip switch settings: the 1st example shows a device *not addressed* where all dip switch settings are in the *default "Off" position*, the 2nd illustrates an *addressed PAD device* via the dip switch settings.

Figure 2. Examples of PAD Device Showing Default Dip Switch Setting (Unaddressed) & Addressed PAD Device

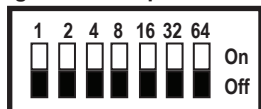

All dip switches are shown in the "Off" position.

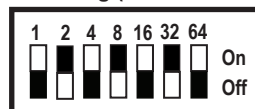

Example shows this PAD device's address = 42. Dip switches #2, 8 & 32 are in the "On" position.

INSTALLATION MANUAL: PAD100-DIM DUAL INPUT MODULE

When the PAD100-DIM is used to monitor two individual Class B circuits a single device address is assigned; each input is then identified as a sub-point of the module address. For example, if the address number is assigned as "8", the first input will be "8.1", and the second input will be "8.2."

Before connecting a device to the SLC loop, take the following precautions to prevent potential damage to the SLC or device.

- Power to the SLC is removed.
- Field wiring on module is correctly installed.
- Field wiring has no open or short circuits.

3. Technical Specifications

Operating Voltage	24.0V
Max SLC Standby Current	240 μ A
Max SLC Alarm Current	240 μ A
Max Wiring Resistance of IDC	100 Ω
Max Wiring Capacitance of IDC	1 μ F
Max IDC Voltage	2.05 VDC
Max IDC Current	120 μ A
EOL Resistor	5.1K Ω
Operating Temperature Range	32° to 120° F (0° to 49° C)
Operating Humidity Range	0 to 93% (non-condensing)
Max no. of Module Per Loop	127 units
Dimensions	4.17" L x 4.17" W x 1.14" D
Mounting Options	UL Listed 2-1/2" deep 2-gang box or 1-1/2" deep 4" square box
Shipping Weight	0.6 lbs

4. Wiring Diagrams

The two wiring diagrams shown below illustrate how to wire a PAD100-DIM module as a Class A and Class B circuit. Additionally, an installation diagram shows how to install the module using a compatible electrical box.

Figure 3. Example of Installing a PAD100-DIM Using a Compatible Electrical Box

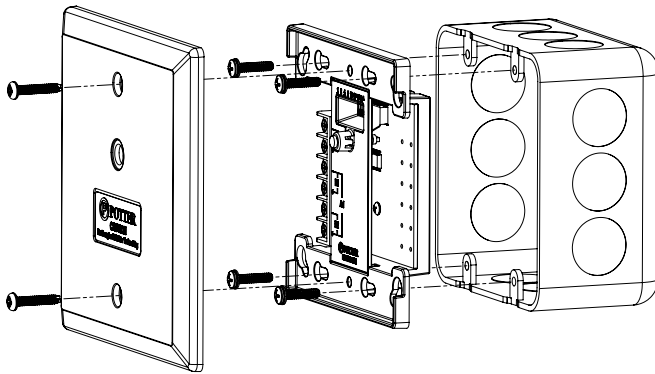

INSTALLATION MANUAL: PAD100-DIM DUAL INPUT MODULE

Figure 4. Example of Wiring a PAD100-DIM with One Class A Circuit

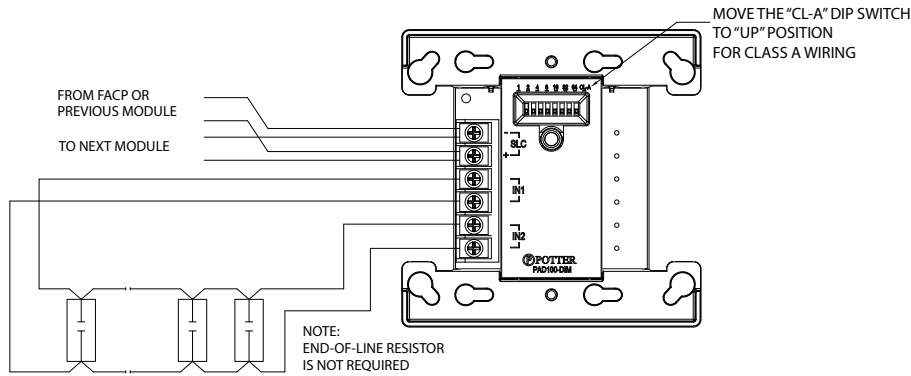
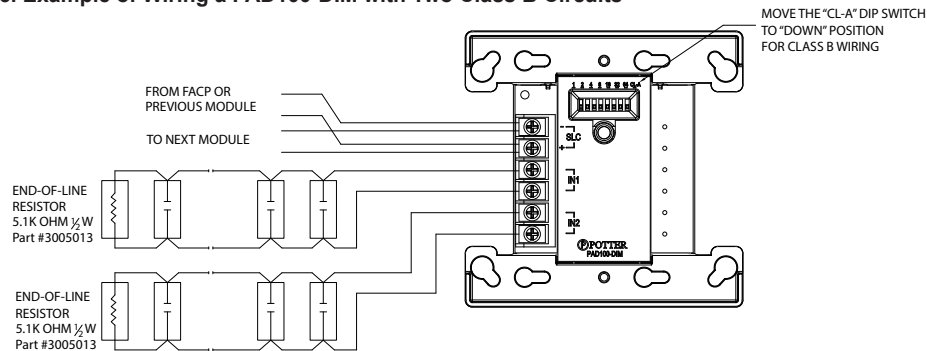

Figure 5. Example of Wiring a PAD100-DIM with Two Class B Circuits



Notes:

- SLC wiring style supports the Class A, Class B and Class X.
- IDC wiring style supports Class A and Class B.
- SLC loop wiring (SLC+, SLC-) and initiating device wiring (IN1, IN2) are power limited.
- Wiring for terminals SLC+, SLC- are supervised.
- Wiring for terminals (IN1, IN2) are supervised.
- This addressable module does not support 2-wire detectors.
- All wiring is between #12 (max.) and #22 (min.).
- Wire Preparation – Strip all wires 1/4 inch from their edges as shown here:



- Stripping too much insulation may cause a ground fault.
- Stripping too little may cause a poor connection and subsequently an open circuit.

These instructions do not purport to cover all the details or variations in the equipment described, nor provide for every possible contingency to be met in connection with installation, operation and maintenance.

Specifications subject to change without prior notification.

For Technical Assistance contact Potter Electric Signal Company at 866-956-1211.

Actual performance is based on proper application of the product by a qualified professional.

Should further information be desired or should particular problems arise, which are not covered sufficiently for the purchaser's purpose, the matter should be referred to a distributor in your region.