

Fire Alarm Control Panel  
**NFS2-640/E**  
Installation Manual



# Fire Alarm & Emergency Communication System Limitations

*While a life safety system may lower insurance rates, it is not a substitute for life and property insurance!*

**An automatic fire alarm system**—typically made up of smoke detectors, heat detectors, manual pull stations, audible warning devices, and a fire alarm control panel (FACP) with remote notification capability—can provide early warning of a developing fire. Such a system, however, does not assure protection against property damage or loss of life resulting from a fire.

**An emergency communication system**—typically made up of an automatic fire alarm system (as described above) and a life safety communication system that may include an autonomous control unit (ACU), local operating console (LOC), voice communication, and other various interoperable communication methods—can broadcast a mass notification message. Such a system, however, does not assure protection against property damage or loss of life resulting from a fire or life safety event.

The Manufacturer recommends that smoke and/or heat detectors be located throughout a protected premises following the recommendations of the current edition of the National Fire Protection Association Standard 72 (NFPA 72), manufacturer's recommendations, State and local codes, and the recommendations contained in the Guide for Proper Use of System Smoke Detectors, which is made available at no charge to all installing dealers. This document can be found at <http://www.systemsensor.com/appguides/>. A study by the Federal Emergency Management Agency (an agency of the United States government) indicated that smoke detectors may not go off in as many as 35% of all fires. While fire alarm systems are designed to provide early warning against fire, they do not guarantee warning or protection against fire. A fire alarm system may not provide timely or adequate warning, or simply may not function, for a variety of reasons:

**Smoke detectors** may not sense fire where smoke cannot reach the detectors such as in chimneys, in or behind walls, on roofs, or on the other side of closed doors. Smoke detectors also may not sense a fire on another level or floor of a building. A second-floor detector, for example, may not sense a first-floor or basement fire.

**Particles of combustion or "smoke"** from a developing fire may not reach the sensing chambers of smoke detectors because:

- Barriers such as closed or partially closed doors, walls, chimneys, even wet or humid areas may inhibit particle or smoke flow.
- Smoke particles may become "cold," stratify, and not reach the ceiling or upper walls where detectors are located.
- Smoke particles may be blown away from detectors by air outlets, such as air conditioning vents.
- Smoke particles may be drawn into air returns before reaching the detector.

The amount of "smoke" present may be insufficient to alarm smoke detectors. Smoke detectors are designed to alarm at various levels of smoke density. If such density levels are not created by a developing fire at the location of detectors, the detectors will not go into alarm.

Smoke detectors, even when working properly, have sensing limitations. Detectors that have photoelectronic sensing chambers tend to detect smoldering fires better than flaming fires, which have little visible smoke. Detectors that have ionizing-type sensing chambers tend to detect fast-flaming fires better than smoldering fires.

Because fires develop in different ways and are often unpredictable in their growth, neither type of detector is necessarily best and a given type of detector may not provide adequate warning of a fire.

Smoke detectors cannot be expected to provide adequate warning of fires caused by arson, children playing with matches (especially in bedrooms), smoking in bed, and violent explosions (caused by escaping gas, improper storage of flammable materials, etc.).

**Heat detectors** do not sense particles of combustion and alarm only when heat on their sensors increases at a predetermined rate or reaches a predetermined level. Rate-of-rise heat detectors may be subject to reduced sensitivity over time. For this reason, the rate-of-rise feature of each detector should be tested at least once per year by a qualified fire protection specialist. Heat detectors are designed to protect property, not life.

**IMPORTANT! Smoke detectors** must be installed in the same room as the control panel and in rooms used by the system for the connection of alarm transmission wiring, communications, signaling, and/or power. If detectors are not so located, a developing fire may damage the alarm system, compromising its ability to report a fire.

**Audible warning devices such as bells, horns, strobes, speakers and displays** may not alert people if these devices are located on the other side of closed or partly open doors or are located on another floor of a building. Any warning device may fail to alert people with a disability or those who have recently consumed drugs, alcohol, or medication. Please note that:

- An emergency communication system may take priority over a fire alarm system in the event of a life safety emergency.
- Voice messaging systems must be designed to meet intelligibility requirements as defined by NFPA, local codes, and Authorities Having Jurisdiction (AHJ).
- Language and instructional requirements must be clearly disseminated on any local displays.
- Strobes can, under certain circumstances, cause seizures in people with conditions such as epilepsy.
- Studies have shown that certain people, even when they hear a fire alarm signal, do not respond to or comprehend the meaning of the signal. Audible devices, such as horns and bells, can have different tonal patterns and frequencies. It is the property owner's responsibility to conduct fire drills and other training exercises to make people aware of fire alarm signals and instruct them on the proper reaction to alarm signals.
- In rare instances, the sounding of a warning device can cause temporary or permanent hearing loss.

**A life safety system** will not operate without any electrical power. If AC power fails, the system will operate from standby batteries only for a specified time and only if the batteries have been properly maintained and replaced regularly.

**Equipment used in the system** may not be technically compatible with the control panel. It is essential to use only equipment listed for service with your control panel.

**Telephone lines** needed to transmit alarm signals from a premises to a central monitoring station may be out of service or temporarily disabled. For added protection against telephone line failure, backup radio transmission systems are recommended.

**The most common cause** of life safety system malfunction is inadequate maintenance. To keep the entire life safety system in excellent working order, ongoing maintenance is required per the manufacturer's recommendations, and UL and NFPA standards. At a minimum, the requirements of NFPA 72 shall be followed. Environments with large amounts of dust, dirt, or high air velocity require more frequent maintenance. A maintenance agreement should be arranged through the local manufacturer's representative. Maintenance should be scheduled as required by National and/or local fire codes and should be performed by authorized professional life safety system installers only. Adequate written records of all inspections should be kept.

Limit-D2-2016

# Installation Precautions

*Adherence to the following will aid in problem-free installation with long-term reliability:*

**WARNING - Several different sources of power can be connected to the fire alarm control panel.** Disconnect all sources of power before servicing. Control unit and associated equipment may be damaged by removing and/or inserting cards, modules, or interconnecting cables while the unit is energized. Do not attempt to install, service, or operate this unit until manuals are read and understood.

## **CAUTION - System Re-acceptance Test after Software**

**Changes:** To ensure proper system operation, this product must be tested in accordance with NFPA 72 after any programming operation or change in site-specific software. Re-acceptance testing is required after any change, addition or deletion of system components, or after any modification, repair or adjustment to system hardware or wiring. All components, circuits, system operations, or software functions known to be affected by a change must be 100% tested. In addition, to ensure that other operations are not inadvertently affected, at least 10% of initiating devices that are not directly affected by the change, up to a maximum of 50 devices, must also be tested and proper system operation verified.

**This system** meets NFPA requirements for operation at 0-49° C/ 32-120° F and at a relative humidity 93% ± 2% RH (non-condensing) at 32°C ± 2°C (90°F ± 3°F). However, the useful life of the system's standby batteries and the electronic components may be adversely affected by extreme temperature ranges and humidity. Therefore, it is recommended that this system and its peripherals be installed in an environment with a normal room temperature of 15-27° C/60-80° F.

**Verify that wire sizes are adequate** for all initiating and indicating device loops. Most devices cannot tolerate more than a 10% I.R. drop from the specified device voltage.

**Like all solid state electronic devices**, this system may operate erratically or can be damaged when subjected to lightning induced transients. Although no system is completely immune from lightning transients and interference, proper grounding will reduce susceptibility. Overhead or outside aerial wiring is not recommended, due to an increased susceptibility to nearby lightning strikes. Consult with the Technical Services Department if any problems are anticipated or encountered.

**Disconnect AC power and batteries** prior to removing or inserting circuit boards. Failure to do so can damage circuits.

**Remove all electronic assemblies** prior to any drilling, filing, reaming, or punching of the enclosure. When possible, make all cable entries from the sides or rear. Before making modifications, verify that they will not interfere with battery, transformer, or printed circuit board location.

**Do not tighten screw terminals** more than 9 in-lbs. Over-tightening may damage threads, resulting in reduced terminal contact pressure and difficulty with screw terminal removal.

**This system contains static-sensitive components.** Always ground yourself with a proper wrist strap before handling any circuits so that static charges are removed from the body. Use static suppressive packaging to protect electronic assemblies removed from the unit.

**Units with a touchscreen display** should be cleaned with a dry, clean, lint free/microfiber cloth. If additional cleaning is required, apply a small amount of Isopropyl alcohol to the cloth and wipe clean. Do not use detergents, solvents, or water for cleaning. Do not spray liquid directly onto the display.

**Follow the instructions** in the installation, operating, and programming manuals. These instructions must be followed to avoid damage to the control panel and associated equipment. FACP operation and reliability depend upon proper installation.

Precau-D2-11-2017

## FCC Warning

**WARNING:** This equipment generates, uses, and can radiate radio frequency energy and if not installed and used in accordance with the instruction manual may cause interference to radio communications. It has been tested and found to comply with the limits for Class A computing devices pursuant to Subpart B of Part 15 of FCC Rules, which is designed to provide reasonable protection against such interference when devices are operated in a commercial environment. Operation of this equipment in a residential area is likely to cause interference, in which case the user will be required to correct the interference at his or her own expense.

### Canadian Requirements

This digital apparatus does not exceed the Class A limits for radiation noise emissions from digital apparatus set out in the Radio Interference Regulations of the Canadian Department of Communications.

Le present appareil numerique n'emet pas de bruits radio-electriques depassant les limites applicables aux appareils numeriques de la classe A prescrites dans le Reglement sur le brouillage radioelectrique edicte par le ministere des Communications du Canada.

HARSH™, NIS™, and NOTI-FIRE-NET™ are all trademarks; and Acclimate® Plus™, eVance®, FlashScan®, FFAST Fire Alarm Aspiration Sensing Technology®, Honeywell®, Intelligent FFAST®, NOTIFIER®, ONYX®, ONYXWorks®, SWIFT®, VeriFire®, and VIEW® are all registered trademarks of Honeywell International Inc. Microsoft® and Windows® are registered trademarks of the Microsoft Corporation. Chrome™ and Google™ are trademarks of Google Inc. Firefox® is a registered trademark of The Mozilla Foundation.

©2019 by Honeywell International Inc. All rights reserved. Unauthorized use of this document is strictly prohibited.

## Software Downloads

In order to supply the latest features and functionality in fire alarm and life safety technology to our customers, we make frequent upgrades to the embedded software in our products. To ensure that you are installing and programming the latest features, we strongly recommend that you download the most current version of software for each product prior to commissioning any system. Contact Technical Support with any questions about software and the appropriate version for a specific application.

## Documentation Feedback

Your feedback helps us keep our documentation up-to-date and accurate. If you have any comments or suggestions about our online Help or printed manuals, you can email us.

Please include the following information:

- Product name and version number (if applicable)
- Printed manual or online Help
- Topic Title (for online Help)
- Page number (for printed manual)
- Brief description of content you think should be improved or corrected
- Your suggestion for how to correct/improve documentation

Send email messages to:

**FireSystems.TechPubs@honeywell.com**

Please note this email address is for documentation feedback only. If you have any technical issues, please contact Technical Services.

# Table of Contents

<b>Section 1: About This Manual</b> .....	<b>7</b>
1.1: Standards and Other Documents .....	7
1.1.1: UL 864 9th and 10th Edition .....	7
1.2: Related Documents .....	8
1.3: Cautions and Warnings .....	9
<b>Section 2: System Overview</b> .....	<b>10</b>
2.1: System Description .....	10
2.1.1: Standard Features .....	10
2.1.2: Options .....	10
2.1.3: System Limitations .....	10
2.2: System Components .....	11
2.2.1: Basic Equipment .....	11
2.2.2: Control Panel Circuit Board .....	11
2.2.3: Main Power Supply (CPS-24/E) .....	11
2.2.4: Circuit Board Components .....	13
2.3: System Cabinets .....	15
2.4: Compatible Equipment .....	15
<b>Section 3: Installation</b> .....	<b>18</b>
3.1: Preparing for Installation .....	18
3.1.1: Standards and Codes .....	18
3.2: Installation Checklist .....	19
3.3: Mounting a Cabinet .....	19
3.4: Laying Out Equipment in Cabinet and Chassis .....	20
3.5: Installing the Control Panel .....	24
3.5.1: Control Panel Circuit Board & Keypad/Display Unit .....	24
3.5.2: Using NCA-2 as Primary Display .....	25
3.5.3: Using the NCD as Primary Display on the NFS2-640 .....	25
3.6: Mounting Option Boards .....	25
3.6.1: Option Boards in the NFS2-640/E Chassis .....	25
3.6.2: Option Boards in CHS-4L .....	26
3.6.3: Option Boards on BMP-1 in Dress Panels .....	28
3.6.4: Transmitter Module TM-4 .....	28
3.6.5: Loop Expander Module .....	28
3.6.6: Network Communications Module .....	29
3.6.7: DVC Digital Voice Command .....	29
3.7: Connecting the Power Cables .....	30
3.7.1: Overview .....	30
3.7.2: Connecting the Control Panel to AC Power .....	31
3.7.3: Checking AC Power .....	31
3.7.4: Installing and Connecting the Batteries .....	31
3.7.5: External DC Power Output Connections .....	32
3.7.6: Accessories DC Power Output Connections .....	32
3.8: NAC Connections and Releasing Circuits .....	33
3.8.1: Stat-X Devices .....	34
3.8.2: FSA-8000 Wiring: .....	34
3.9: Output Relay Connections .....	35
3.10: Backup-Alarm Switches .....	35
3.11: UL Power-limited Wiring Requirements .....	36
3.11.1: Labeling Modules and Circuits .....	36
3.12: Installing EIA-485 Devices .....	37
3.13: Installing Remote Printers and/or CRT .....	37
3.13.1: Custom Cable Fabrication .....	37
3.13.2: Installing and Configuring the PRN Series Printer .....	37
3.13.3: Installing and Configuring a Keltron Printer .....	38
3.13.4: Installing and Configuring a CRT-2 .....	39
3.13.5: Connecting Multiple Printers, CRTs, or CRT/PRN Combination .....	41
3.14: Wiring a Signaling Line Circuit (SLC) .....	42
3.15: Connecting a PC for Off-Line Programming .....	43

<b>Section 4: Applications</b>	<b>44</b>
4.1: Overview	44
4.2: Devices Requiring External Power Supervision	44
4.3: NFPA 72 Central or Remote Station Fire Alarm System (Protected Premises Unit)	44
4.4: Central Station Fire Alarm System Canadian Requirements	46
4.5: NFPA 72 Proprietary Fire Alarm Systems	47
4.6: Fire/Security Applications	47
4.6.1: General Operation	47
4.6.2: Installing a Security Tamper Switch	47
4.6.3: Receiving Unit	48
4.6.4: Programming	48
4.6.5: Wiring for Proprietary Security Alarm Applications	48
4.7: Releasing Applications	49
4.7.1: Overview	49
4.7.2: Programming	49
4.7.3: Connecting a Releasing Device to the Control Panel	49
4.7.4: Connecting a Releasing Device to the FCM-1 Module	51
4.7.5: Connecting Releasing Devices to the FCM-1-REL Control Module	53
4.7.6: Connecting an NBG-12LRA Agent Release-Abort Station	54
<b>Section 5: Testing the System</b>	<b>55</b>
5.1: Acceptance Test	55
5.2: Periodic Testing and Service	55
5.3: Operational Checks	55
5.4: Battery Checks and Maintenance	55
<b>Appendix A: Power Supply Calculations</b>	<b>57</b>
A.1: Calculating AC Branch Circuit Current	57
A.2: Calculating the System Current Draws	57
A.2.1: Calculating the Maximum Secondary Power Fire Alarm Current Draw	59
A.3: Calculating the Battery Requirements	60
A.3.1: Calculating the Battery Capacity	60
A.3.2: Calculating the Battery Size	60
<b>Appendix B: Electrical Specifications</b>	<b>61</b>
B.1: Electrical Specifications	61
B.2: Wire Requirements	62
<b>Appendix C: Canadian Applications</b>	<b>64</b>
C.1: Standalone Application	64
C.1.1: NFS2-640/E with KDM-R2	64
C.1.2: NFS2-640/E with NCA-2	64
C.2: Network Applications	64
C.3: Automatic Alarm Signal Silence	64
C.4: Annunciator Applications	64
C.5: Releasing Devices	64
C.6: Ancillary Devices	64
C.7: Isolating NACs with Audio Isolator Modules	64
C.7.1: Description of Modules	64

# Section 1: About This Manual

## 1.1 Standards and Other Documents

### ■ This Fire Alarm Control Panel complies with the following NFPA standards:

- NFPA 12 CO<sub>2</sub> Extinguishing Systems
- NFPA 12A Halon 1301 Extinguishing Systems
- NFPA 13 Sprinkler Systems
- NFPA 15 Water Spray Systems
- NFPA 16 Foam/Water Deluge and Foam/Water Spray Systems
- NFPA 17 Dry Chemical Extinguishing Systems
- NFPA 17A Wet Chemical Extinguishing Systems
- NFPA 70 National Electrical Code
- NFPA 72 Central Station Fire Alarm Systems (Automatic, Manual and Waterflow) Protected Premises Unit (requires Notifier UDACT/UDACT-2).
- NFPA 72 Local (Automatic, Manual, Waterflow and Sprinkler Supervisory) Fire Alarm Systems.
- NFPA 72 Auxiliary (Automatic, Manual and Waterflow) Fire Alarm Systems (requires TM-4).
- NFPA 72 Remote Station (Automatic, Manual and Waterflow) Fire Alarm Systems
- NFPA 72 Proprietary (Automatic, Manual and Waterflow) Fire Alarm Systems (Protected Premises Unit).
- NFPA 92 Standard for Smoke-Control Systems
- NFPA 2001 Clean Agent Fire Extinguishing Systems
- NFPA 2010 Standard for Fixed Aerosol Fire Extinguishing Systems

### ■ The installer should be familiar with the following documents and standards:

- NFPA 72 Initiating Devices for Fire Alarm Systems
- NFPA 72 Inspection, Testing and Maintenance for Fire Alarm Systems
- NFPA 72 Notification Appliances for Fire Alarm Systems

#### Underwriters Laboratories

- UL 38 Manually Actuated Signaling Boxes
- UL 217 Smoke Detectors, Single and Multiple Station
- UL 228 Door Closers - Holders for Fire Protective Signaling Systems
- UL 268 Smoke Detectors for Fire Protective Signaling Systems
- UL 268A Smoke Detectors for Duct Applications
- UL 346 Waterflow Indicators for Fire Protective Signaling Systems
- UL 464 Audible Signaling Appliances
- UL 521 Heat Detectors for Fire Protective Signaling Systems
- UL 864 Standard for Control Units for Fire Protective Signaling Systems, 10th edition
- UL 1481 Power Supplies for Fire Protective Signaling Systems
- UL 1971 Visual Signaling Appliances
- UL 1076 Proprietary Burglar Alarm Systems
- UL 2017 Standard for General-Purpose Signaling Devices and Systems
- UL 2572 Standard for Mass Notification Systems
- UL 60950 Safety of Information Technology Equipment

#### Underwriters Laboratories of Canada (ULC)

- Standard CAN/ULC-S527-M99
- CAN/ULC-S524-M91 Standard for the Installation of Fire Alarm Systems
- ULC S524 Standard for the Installation of Fire Alarm Systems
- ULC-S527-11 Standard for Control Units for Fire Alarm Systems
- ULC S561 Installation and Services for Fire Signal Receiving Centres and Systems

#### Other

- EIA-485 and EIA-232 Serial Interface Standards
- NEC Article 300 Wiring Methods
- NEC Article 760 Fire Protective Signaling Systems
- Applicable Local and State Building Codes
- Requirements of the Local Authority Having Jurisdiction

### 1.1.1 UL 864 9th and 10th Edition

Per the UL Continuing Certification Program, UL 864 9th edition fire alarm control equipment will retain certification after the rollout of UL 10th edition (12/2/2018).

Installations of UL 864 10th Edition certified equipment are permitted to use UL864 9th Edition certified equipment when approved by the local Authority Having Jurisdiction (AHJ).



For product compliance, refer to the UL/ULC listing cards located on the UL online certification directory. UL Product iQ:  
<https://iq.ulprospector.com/en/>

## 1.2 Related Documents

Table 1.1 below provides a list of documents referenced in this manual, as well as documents for selected other compatible devices. The document series chart (DOC-NOT) provides the current document revision. A copy of this document is included in every shipment.

<b>Compatible Conventional Devices (Non-addressable)</b>	<b>Document Number</b>
Device Compatibility Document	15378
<b>Fire Alarm Control Panel (FACP) and Main Power Supply Installation</b>	<b>Document Number</b>
NFS2-640/E Installation, Operations, and Programming Manuals	52741, 52742, 52743
DVC Digital Voice Command Manual	52411
DVC-RPU Manual	50107425-001
DVC-RPU UL Listing Document	50107424-001
DAL Devices Reference Document	52410
DS-DB Digital Series Distribution Board and Amplifier Manual	53622
DAA2 and DAX Amplifiers Manual	53265
SLC Wiring Manual	51253
Note: For individual SLC Devices, refer to the <i>SLC Wiring Manual</i>	
<b>Off-line Programming Utility</b>	<b>Document Number</b>
VeriFire® Tools CD help file	VERIFIRE-TCD
<b>Cabinets &amp; Chassis</b>	<b>Document Number</b>
CAB-3/CAB-4 Series Cabinet Installation Document	15330
Heat Dissipation for Cabinets with Audio Products*	53645
Battery/Peripherals Enclosure Installation Document	50295
<b>Power Supplies, Auxiliary Power Supplies &amp; Battery Chargers</b>	<b>Document Number</b>
ACPS-2406 Installation Manual	51304
ACPS-610 Installation Manual	53018
APS-6R Instruction Manual	50702
APS2-6R Instruction Manual	53232
CHG-120 Battery Charger Manual	50641
FCPS-24 Field Charger/Power Supply Manual	50059
FCPS-24S6/FCPS-24S8 Field Charger/Power Supply Manual	51977
<b>Networking</b>	<b>Document Number</b>
High-Speed NCM Installation Document	54014
Noti•Fire•Net Manual, Network Version 5.0 & Higher	51584
NCM-W/F Installation Document	51533
HS-NFN Installation Document	54013
ONYXWorks™ Workstation Hardware & Software Application: Installation and Operation Manual	52342
ONYXWorks™ NFN Gateway (PC Platform) Installation & Operation Manual	52307
ONYXWorks™ NFN Gateway (Embedded Platform) Installation & Operation Manual	52306
NCS ONYX® Network Control Station Manual, Network Version 4.0 & Higher	51658
NCA-2 Network Control Annunciator Manual	52482
NCA Network Control Annunciator Manual	51482
NCD Network Control Display	LS10210-051NF-E
<b>System Components</b>	<b>Document Number</b>
Annunciator Control System Manual	15842
FDU-80Remote Annunciator Manual	51264
LCD-80 Liquid Crystal Display Remote Annunciator	15037

**Table 1.1 Reference Documentation (1 of 2)**



LCD2-80 Liquid Crystal Display Remote Annunciator	53242
LDM Series Lamp Driver Annunciator Manual	15885
SCS Smoke Control Manual (Smoke and HVAC Control Station)	15712
DPI-232 Direct Panel Interface Manual	51499
TM-4 Installation Document (Reverse Polarity Transmitter)	51490
UDACT Manual (Universal Digital Alarm Communicator/Transmitter)	50050
UDACT-2 Manual (Universal Digital Alarm Communicator/Transmitter)	54089
UDACT-2 Listing Document (Universal Digital Alarm Communicator/Transmitter)	54089LD
AA-Series Audio Amplifiers Manual	52526
ACT-1 Installation Document	52527
ACT-2 Installation Document	51118
FireVoice-25/50, FireVoice-25/50ZS & FireVoice-25/50ZST Manual	52290
FirstCommand Emergency Communication System	LS1001-001NF-E
RM-1 Series Remote Microphone Installation Document	51138
RA100Z Remote LED Annunciator Installation Document	156-0508
XP Transponder Manual	15888
XP10-M Installation Document	156-1803
XP5 Series Manual	50786
XP6-C Installation Document	156-1805
XP6-MA Installation Document	156-1806
XP6-R Installation Document	156-1804
FSA-5000(A) FFAST XS Intelligent Aspiration Sensing Technology Document	156-6008
FSA-8000(A) FFAST XM Intelligent Aspiration Sensing Technology Document	156-3903
FSA-20000(A) FFAST XT PRO Intelligent Aspiration Sensing Technology Document	156-3903
FWSG Wireless Manual	LS10036-000NF-E
Manual Releasing Disconnect (MRD-1) Product Installation Document	LS10231-000GE-E

**Table 1.1 Reference Documentation (2 of 2)**

\* If you are installing the panel in the same cabinet as digital audio equipment, heat dissipation calculations must be made. Please refer to document #53645.

## 1.3 Cautions and Warnings

This manual contains cautions and warnings to alert the reader as follows:



### CAUTION:

Information about procedures that could cause programming errors, runtime errors, or equipment damage.



### WARNING:

Indicates information about procedures that could cause irreversible damage to the control panel, irreversible loss of programming data or personal injury.

## Section 2: System Overview

### 2.1 System Description

The NFS2-640/E control panel is a modular, intelligent fire alarm control panel (FACP) with an extensive list of powerful features. The control panel uses the CPS-24/E integral power supply with battery charger. This is combined with a mounting chassis and cabinet to create a complete fire alarm control system. The panel supports FlashScan® protocol and has network capabilities. A single SLC loop is supported with the basic equipment package; a second SLC loop can be added by attaching an optional loop expander module (LEM-320).

Modular devices mount to the chassis to provide additional output circuits, including voice and telephone modules to form a complete voice evacuation system. Five cabinet options are available for enclosing system components; each is available in red or black.

The control panel has the capacity for installing up to 636 addressable points; 159 detectors and 159 monitor/control modules per SLC (Signaling Line Circuit).

#### 2.1.1 Standard Features

- Uses Notifier's VIEW® early warning fire detection and the FlashScan or Classic Loop Interface Protocol (CLIP) families of detectors and modules
- Integral power supply with battery charger
- Four standard Notification Appliance Circuits (NAC), Class A or B
- Alarm, Trouble, Supervisory and Security relays
- Support for 32 annunciator addresses, with 10 special annunciator groups
- Supports Style 4, Class A, Class B, and Class XSLC loops
- Connections to easily mount an expander board to add a second SLC loop
- Releasing service using on-board NACs or FCM-1 modules
- Logic Equations
- Display scroll selection
- Alarm verification supervisory indication (NYC)
- Supervisory duct detectors
- Supports Advanced Warning Addressable Combustion Sensing (AWACS) algorithms
- Network operation
- Battery charger supports 18 to 200 amp hour sealed lead-acid batteries
- EIA-485 connections for wiring ACS annunciators (including LDM custom graphic annunciators), TM-4 transmitter
- EIA-232 connections for printer, CRT, printer/CRT, or network operation
- Autoprogram feature for faster programming of new devices
- The control panel provides 6 amps of usable output power in an alarm condition; it provides 3 amps of usable output power in normal or continuous operating conditions
- Diagnostic LEDs and switches
- Ground fault detection (0 ohm impedance)
- Battery and battery-charger supervision, voltage-monitoring, and current-monitoring
- Disconnect of deeply-discharged battery (low battery disconnect)
- Programmable for strobe synchronization
- Mass Notification System compatible

#### 2.1.2 Options

Refer to Section 2.4 "Compatible Equipment" for other peripherals listed for use with this panel.

- QWERTY silicone-rubber keypad with a 2x40 LCD display and eight indicator LEDs
- Optional LEM-320 provides a second SLC loop that is electrically identical to the one on the main board
- Optional devices include: UDACT/UDACT-2 Universal Digital Alarm Communicator/Transmitter, ACM-8R remote relay module to increase point capacity, and audio and voice components.
- Optional annunciators connected through the EIA-485 interface allow remote system monitoring.

#### 2.1.3 System Limitations

System expansion must take into consideration the following:

1. The physical limitations of the cabinet configuration.
2. The electrical limitations of the system power supply.
3. The capacity of the secondary power source (standby batteries). (Note that batteries larger than 26 AH will require a separate battery backbox.)



- Powering the NFS2-640/E
- Powering a variety of UL-listed 24 VDC notification appliances from four built-in NAC outputs
- Providing up to 1.25 A of resettable power for four-wire smoke detectors
- Providing up to 1.25 A of non-resettable power for external devices such as the TM-4 Transmitter Module.
- Providing auxiliary 24 VDC power @ 0.5A and 5 VDC power @ 0.15A.
- Fuse: 8 amps, 250 V, 5 x 20 mm, Fast-Acting, ceramic, p/n 12117.

When AC Power is lost, the deeply-discharged battery cutoff protection will be invoked at 17 volts. The power supply will be disconnected from the batteries. The power supply's normal operation will be restored when AC power returns.

See Figure 2.2, "CPU2-640/CPU2-640E and Power-Supply: Wiring Connections" and Figure 2.3, "CPU2-640/CPU2-640E and Power-Supply: Jumpers, LEDs and Switches" for details.

## 2.2.4 Circuit Board Components

The following two figures illustrate the location of the various connections, switches, jumpers and LEDs on the CPU2-640/CPU2-640E and its power supply. Figure 2.2 shows wiring connections; Figure 2.3 shows jumpers, LEDs and switches. See Section 3 “Installation” for larger images and more details. (Larger images are referenced on these drawings.)

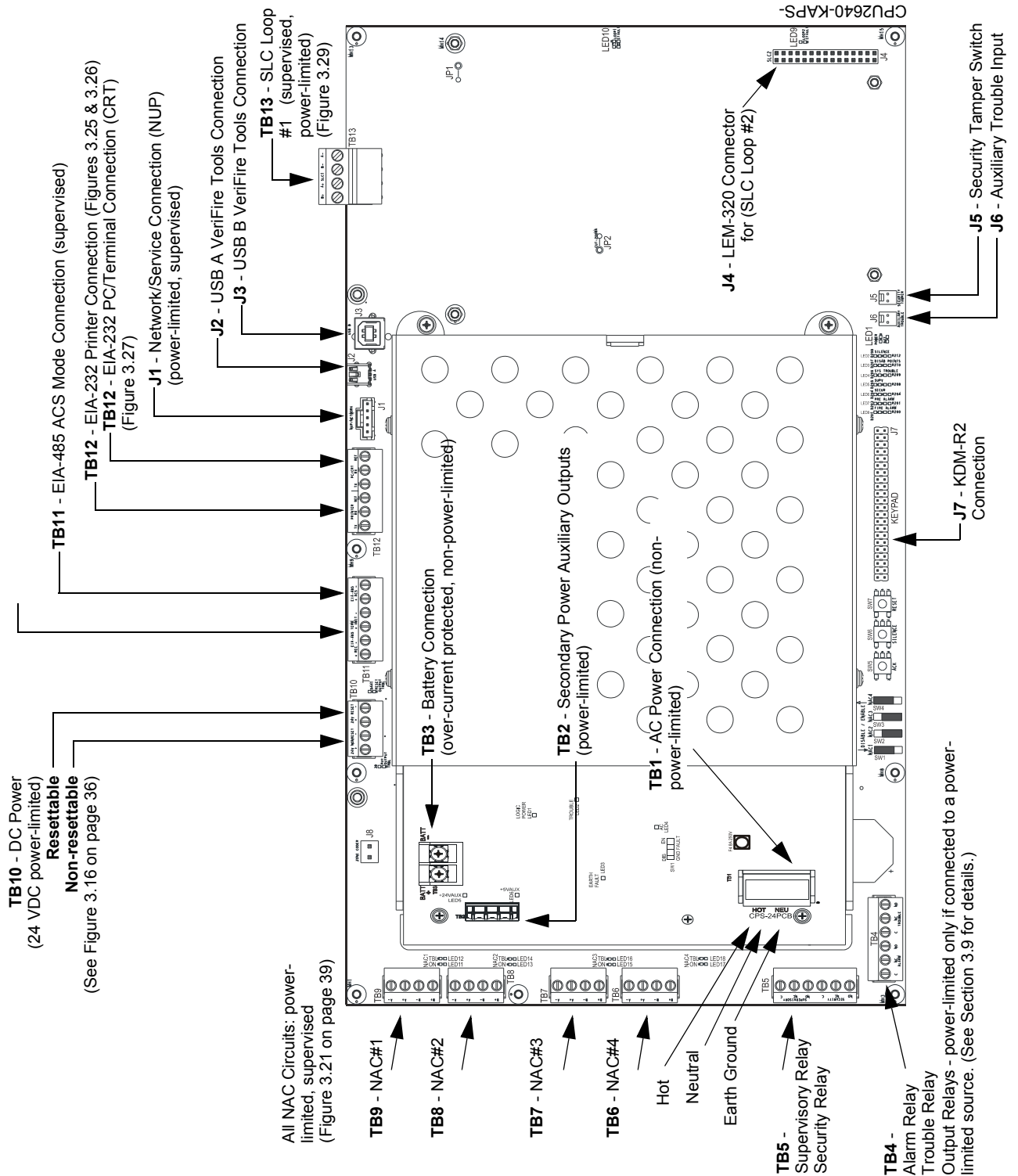


Figure 2.2 CPU2-640/CPU2-640E and Power-Supply: Wiring Connections

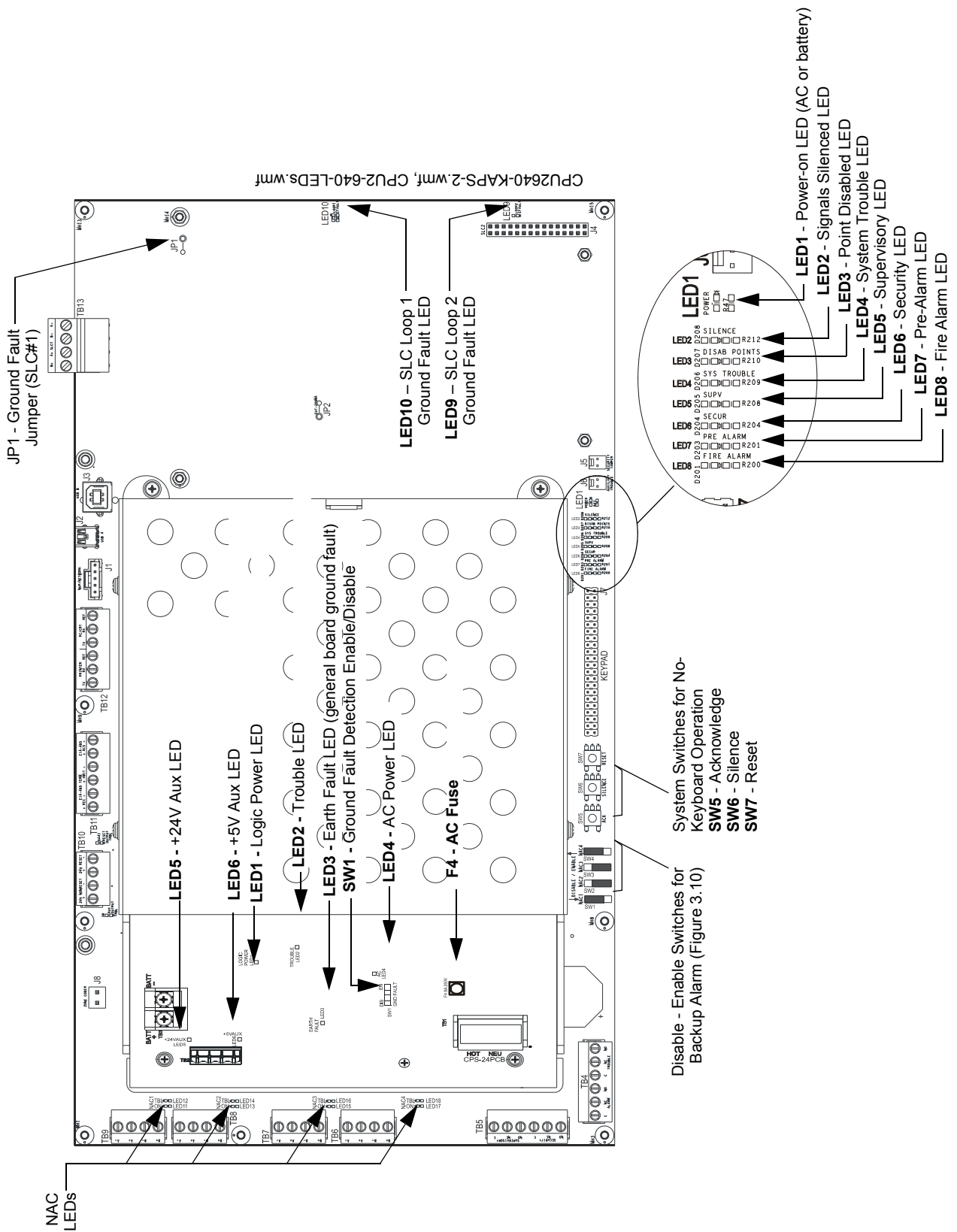


Figure 2.3 CPU2-640/CPU2-640E and Power-Supply: Jumpers, LEDs and Switches

## 2.3 System Cabinets

The control panel and modules are installed in a CAB-4 series backbox. There are four different sizes available, holding from one to four rows of equipment plus batteries (up to two 26 AH batteries). Backboxes are ordered separately from doors. The doors can be mounted on the left or the right side of the cabinet; reversible hinges are provided so that this choice can be made in the field. Doors open a full 180 degrees and have locks. Mounting methods include surface-mounting or semi-flush mounting on a wall between 16 inch (40.64 cm) on-center studs. A trim ring option is available for semi-flush mounting.

External measurements for each backbox are provided below; door dimensions are larger. Refer to *CAB-3/CAB-4 Series Cabinet Installation Document* (shipped with the cabinet) for specific mounting drawings and door dimensions.

<b>A-size backbox (one row)</b>	24.00 in (60.96 cm) wide 20.00 in (50.8 cm) tall 5.218 in (13.254 cm) deep Uses optional trim ring TR-A4	<b>Optional trim ring TR-A4</b> Opening: 24.062 in (61.118 cm) wide; 20.062 in (50.881 cm) tall. Molding width: 1.375 in (3.493 cm)
<b>B-size backbox (two rows)</b>	24.00 in (60.96 cm) wide 28.5 in (72.39 cm) tall 5.218 in (13.254 cm) deep Uses optional trim ring TR-B4	<b>Optional trim ring TR-B4</b> Opening: 24.062 in (61.118 cm) wide; 28.562 in (72.548 cm) tall. Molding width: 1.375 in (3.493 cm)
<b>C-size backbox (three rows)</b>	24.00 in (60.96 cm) wide 37.125 in (94.297 cm) tall 5.218 in (13.254 cm) deep Uses optional trim ring TR-C4	<b>Optional trim ring TR-C4</b> Opening: 24.062 in (61.118 cm) wide; 37.187 in (94.455 cm) tall. Molding width: 1.375 in (3.493 cm)
<b>D-size backbox (four rows)</b>	24.00 in (60.96 cm) wide 45.75 in (1162.05 cm) tall 5.218 in (13.254 cm) deep Uses optional trim ring TR-D4	<b>Optional trim ring TR-D4</b> Opening: 24.062 in (61.118 cm) wide; 45.812 in (114.775 cm) tall. Molding width: 1.375 in (3.493 cm)
<b>Trim Rings:</b> When using trim rings, mount backbox with at least 1 inch (2.54 cm) between wall surface and front of backbox, to allow door to open fully past the trim ring.		

For details on mounting options within the cabinet, see Section 3.4, “Laying Out Equipment in Cabinet and Chassis”.

## 2.4 Compatible Equipment

These are the most common devices at time of publishing; the most complete list of compatible intelligent SLC loop devices is provided in the *SLC Wiring Manual*; for conventional non-addressable equipment see the *Device Compatibility Document*. These devices are UL and ULC listed unless marked otherwise (in parentheses next to the product). Other control panels and their equipment can also be connected in a network, via Noti•Fire•Net version 5.0 or the High-Speed Noti•Fire•Net; refer to the *Noti•Fire•Net Version 5.0 & Higher Installation Manual* or the *High-Speed Noti•Fire•Net Installation Manual* for details. For products documented separately, see Section 1.3 “Related Documents”.



### WARNING: UL 9TH COMPLIANCE

THIS PRODUCT HAS BEEN CERTIFIED TO COMPLY WITH THE REQUIREMENTS IN THE STANDARD FOR CONTROL UNITS AND ACCESSORIES FOR FIRE ALARM SYSTEMS, UL 864 9TH EDITION. OPERATION OF THE NFS2-640/E WITH PRODUCTS NOT TESTED FOR UL 864 9TH EDITION HAS NOT BEEN EVALUATED AND MAY NOT COMPLY WITH NFPA 72 AND/OR THE LATEST EDITION OF UL 864. THESE APPLICATIONS WILL REQUIRE THE APPROVAL OF THE LOCAL AUTHORITY HAVING JURISDICTION (AHJ). PERIPHERAL DEVICES IN THE SECOND LIST WERE LISTED UNDER UL 8TH EDITION AND MAY ONLY BE USED IN RETROFIT APPLICATIONS (SEE SECTION 1.2, “UL 864 COMPLIANCE”, ON PAGE 8).

### Notifier® Compatible Equipment

- “A” or “CDN” suffix indicates a ULC Listed model.
- “IV” suffix indicates ivory color and is a FlashScan and CLIP device
- Products marked with a check mark have not received UL 864 9th Edition certification and may only be used in retrofit applications.
- The wireless option is not suitable for ULC.

#### Electronic Equipment

**AA-100** 100-Watt Audio Amplifier  
**AA-120** 120-Watt Audio Amplifier  
**AA-30** 30-Watt Audio Amplifier  
**ACM-24AT** Annunciator Control Module  
**ACM-48A** Annunciator Control Module  
**ACM-8R** Annunciator Control Module  
**ACPS-610** Addressable Charger/Power Supply  
**ACPS2-6R** Auxiliary Power Supply  
**ACT-1** Audio Coupling Transformer  
**ACT-2** Audio Coupling Transformer  
**AcclimatePlus FAPT-751** Combination Photoelectric/Heat Detector

**AcclimatePlus FAPT-851** Combination Photoelectric/Heat Detector  
**AEM-24AT** Annunciator Expander Module  
**AEM-48A** Annunciator Expander Module  
**AKS-1B** Annunciator Key Switch  
**APJ-1B** Annunciator Phone Jack-G  
**APS2-6R** Auxiliary Power Supply (for UL applications only)  
**A77-716B** End-of-Line Resistor Assembly  
**B200S** Intelligent Programmable Sounder Base  
**B200S-IV** Intelligent Programmable Sounder Base Ivory  
**B200S-WH** Intelligent Programmable Sounder Base White  
**B200S-LF** Low-Frequency Intelligent Programmable Sounder Base

**B200S-LF-IV** Low-Frequency Intelligent Programmable Sounder Base Ivory  
**B200S-LF-WH** Low-Frequency Intelligent Programmable Sounder Base White  
**B200SA** Intelligent Sounder Base  
**B200SA-IV** Intelligent Sounder Base Ivory  
**B200SA-WH** Intelligent Sounder Base White  
**B200SCOA** Intelligent Programmable Sounder Base  
**B200SCOA-IV** Intelligent Programmable Sounder Base Ivory  
**B200SCOA-WH** Intelligent Programmable Sounder Base White  
**B200SR** Intelligent Sounder Base  
**B200SR-IV** Intelligent Sounder Base Ivory  
**B200SR-WH** Intelligent Sounder Base White  
**B200SR-LF** Low-Frequency Intelligent Sounder Base  
**B200SR-LF-IV** Low-Frequency Intelligent Sounder Base Ivory  
**B200SR-LF-WH** Low-Frequency Intelligent Sounder Base White  
**B200SRA** Intelligent Sounder Base  
**B200SRA-IV** Intelligent Sounder Base Ivory  
**B200SRA-WH** Intelligent Sounder Base White  
**B210LP** Flange Mounted Base  
**B210LPA** ULC Flange Mounted Base  
**B210LPBP** Bulk Pack of B300-6. Package of 10  
**B224BI** Isolator Bases for Low-profile Detectors  
**B224BI-IV** Isolator Bases for Low-profile detectors Ivory  
**B224BI-WH** Isolator Bases for Low-profile detectors White  
**B224BIA** Isolator Base for Low-profile detectors  
**B224BIA-IV** Isolator Base for Low-profile detectors Ivory  
**B224BIA-WH** Isolator Base for Low-profile detectors White  
**B224RB** Low-profile Relay Base  
**B224RB-IV** Low-profile Relay base Ivory  
**B224RB-WH** Low-profile Relay base White  
**B224RBA** Low-profile Relay base  
**B224RBA-IV** Low-profile Relay base Ivory  
**B224RBA-WH** Low-profile Relay base White  
**B300-6** Intelligent Detector Base 6 Inch White  
**B300-6-IV** Intelligent Detector Base 6 Inch Ivory  
**B300A-6** Intelligent Detector Base 6 Inch White Canada  
**B300A-6-IV** Intelligent Base 6 Inch Ivory Canada  
**BX-501** Intelligent Detectors/Sensors Base  
**B501** USA Intelligent Detector Base  
**B501A** ULC Intelligent Detector Base  
**B501BH-2** Sounder Base  
**B501BHT-2** Temporal Sounder Base  
**B501-White** Intelligent Detector Base White  
**B501-BL** Intelligent Detector Base Black  
**B501-IV** Intelligent Detector Base Ivory  
**B710HD** HARSH Detector Base  
**B710LP** European Intelligent Detector Base  
**BAT-12120** Battery 12-volt, 12 amp-hour  
**BAT-12180** Battery 12-volt, 18 amp-hour  
**BAT-12250** Battery 12-volt, 25 amp-hour  
**BAT-12260** Battery 12-volt, 26 amp-hour  
**BAT-12550** Battery 12-volt, 55 amp-hour  
**BAT-12600** Battery 12-volt, 60 amp-hour  
**BDA-25V/75V** Backup Amplifier  
**CK300** Color Kit White  
**CK300-IR** Color Kit White with IR Opening  
**CK300-IV** Color Kit Ivory  
**CK300-IR-IV** Color Kit Ivory with IR Opening  
**CK300-BL** Color Kit Black  
**CK300-IR-BL** Color Kit Black with IR Opening  
**CMM-1** Communication converter Module  
**CMX-1** Addressable Control Module  
**CMX-2** Addressable Control Module  
**CPU2-640/E** Control Panel Circuit Board  
**CPX-551** Intelligent Ionization Smoke Detector  
**CPX-751** Intelligent Ionization Smoke Detector  
**CRT-2** Video Display Monitor With Keyboard  
**DAA Series** Digital Audio Amplifiers  
**DAA2** Series Digital Audio Amplifier  
**DAX** Digital Audio Amplifier  
**DHX-501** Duct Detector  
**DHX-502** Duct Detector  
**DNR/W/A** Intelligent Non-Relay Photoelectric Duct Detector  
**DPI-232** Direct Panel Interface  
**DS-AMP** Audio Amplifier  
**DS-BDA** Backup Audio Amplifier  
**DS-DB** Digital Distribution Board  
**DS-XF70V** Transformer  
**DVC-AO** Digital Voice Command Audio Output  
**DVC-EM** Digital Voice Command  
**DVC-RPU** DVC Remote Paging Unit  
**FCM-1** NAC Module  
**FCM-1-REL** Control Module  
**FCO-851** Fire/CO Detector  
**FCO-951(A)** Carbon Monoxide Sensors  
**FCO-951(A)-IV** Carbon Monoxide Sensors Ivory  
**FCPS-24S6/S8** Field Charger/Power Supply  
**FDM-1** Dual Monitor Module  
**FDRM-1** Dual Monitor/Dual Relay  
**FDX-551** Intelligent Thermal Sensor  
**FDX-551R** Intelligent Thermal Rate-of-Rise Sensor  
**FHS** Fireman's Handset  
**FMM-1** Monitor Module  
**FMM-101** Mini Monitor Module  
**FMM-4-20** Monitor Module  
**FPC-951(A)** Multi Criteria PHOTO/CO Detector  
**FPJ** Fireman's Phone Jack  
**FPTI-951(A)** Multi-Criteria Photoelectric, Thermal and Infrared Sensor  
**FPTI-951(A)-IV** Multi-Criteria Photoelectric, Thermal and Infrared Sensor Ivory  
**FRM-1** Relay Module  
**FSA-5000/A (FAAST XS)** Intelligent Aspiration detector  
**FSA-8000/A (FAAST XM)** Intelligent Aspiration detector  
**FSA-20000/A (FAAST XT)** Intelligent Aspiration detector  
**FSA-20000P (FAAST XT PRO)** Intelligent Aspiration detector  
**FSA-851A** Intelligent Aspiration Detector - 06-NF10 Baffle for the FSA-851A  
**FSB-200S** Single Ended Beam Smoke Detector With Sensitivity Testing  
**FSB-200** Single Ended Beam Smoke Detector  
**FSC-851** IntelliQuad Multi-Criteria Smoke Detector  
**FSCO-951(A)** Carbon Monoxide Sensor  
**FSD-751P/RP/PL** Duct Detectors  
**FSH-751 HARSH™** Photo Detector  
**FSI-751** Ion Detector  
**FSI-851** Ion Detector  
**FSL-751 FlashScan VIEW®** Laser Detector  
**FSM-101** Pull Station Monitor Module  
**FS-OSI-RI(A)** Intelligent Single Ended Reflected Type Projected Imaging Beam Smoke Detector  
**FSP-751** Photo Detector  
**FSP-751T** Photo/Thermal Detector  
**FSP-851** Photo Detector, listed for use in ducts  
**FSP-851T** Photo/heat Detector, listed for use in ducts  
**FST-751** Thermal Detector  
**FST-751R** Thermal Rate-of-rise Detector  
**FST-851** Thermal Detector  
**FST-851H** High-temperature Thermal Detector  
**FST-851R** Thermal Rate-of-rise Detector  
**FSP-951** Photo Detector  
**FSP-951-IV** Photo Detector/Dual Protocol Ivory  
**FSP-951R** Photo RAT  
**FSP-951R-IV** Photo RAT/Dual Protocol Ivory  
**FSP-951P** Photo/Thermal  
**FSP-951T-IV** Photo/Thermal/Dual Protocol Ivory  
**FST-951** Programmable Heat  
**FST-951-IV** Programmable Heat/Dual Protocol Ivory  
**FST-951R** Heat Detector Rate of Rise  
**FST-951R-IV** Heat Detector Rate of Rise/Dual Protocol Ivory  
**FST-951H** Heat Detector High  
**FST-951H-IV** Heat Detector High/Dual Protocol Ivory  
**FSV-951(A)** Intelligent High Sensitivity Photoelectric Smoke Detector  
**FSV-951(A)-IV** Intelligent High Sensitivity Photoelectric Smoke Detector Ivory  
**FSV-951RA** Intelligent High Sensitivity Photoelectric Smoke Detector Retrofit  
**FSV-951RA-IV** Intelligent High Sensitivity Photoelectric Smoke Detector Retrofit Ivory  
**FTM-1** Telephone Module  
**FW-MM** Wireless Monitor Module  
**FW-RM** Wireless Relay  
**FWD-200ACCLIMATE** Wireless Acclimate detector  
**FWD-200P** Wireless photo detector  
**FWH-200FIX135** Wireless, fixed-temperature heat detector  
**FWH-200ROR135** Wireless, rate-of-rise heat detector  
**FWSG** Wireless Gateway  
**FZM-1** Zone Module  
**HPX-751 HARSH™** Hostile Environment Smoke Detector  
**HS-NCM-MF** High-Speed Network Communications Module (Multi-Mode Fiber)  
**HS-NCM-MFSF** High-Speed Network Communications Module (Multi-Mode Fiber to Single-Mode Fiber)  
**HS-NCM-SF** High-Speed Network Communications Module (Single-Mode Fiber)  
**HS-NCM-W** High-Speed Network Communications Module (Wire)  
**HS-NCM-WMF** High-Speed Network Communications Module (Wire to Multi-Mode Fiber)  
**HS-NCM-WSF** High-Speed Network Communications Module (Wire to Single-Mode Fiber)  
**HWF2A-COM** IP Digital Alarm Communicator  
**HWF2A-COM** IP Digital Alarm Communicator



**ISO-X** Loop Fault Isolator Module  
**ISO-6/A** Six Fault Isolator Module  
**LCD-80** Liquid Crystal Display Module  
**LCD2-80** Liquid Crystal Display Module  
**LDM-E32** Lamp Driver Module Ivory  
**LDM-R32** Lamp Driver Module  
**LDM-32** Lamp Driver Module  
**LEM-320** Loop Expander Module  
**LDM-E32** Lamp Driver Module Ivory  
**LDM-R32** Lamp Driver Module  
**LDM-32** Lamp Driver Module  
**LEM-320/A** Loop Expander Module  
**MMX-1** Addressable Monitor Module  
**MMX-2** Addressable Monitor Module  
**MMX-101** Addressable Mini Monitor Module  
**MRD-1** Manual Releasing Disconnect Assembly  
**N-ELR** Assortment ELR Pack with Mounting Plate  
**NBG-12 Series** Addressable Manual Pull Station  
**NBG-12LRA** - Agent Release Abort Station  
**NBG-12LX** Addressable Manual Pull Stations  
**NBG-12LXP** Portuguese Labeled Addressable Pull Station  
**NBG12LXSP** Spanish Labeled Addressable Pull Station  
**NCA-2/C** Network Communications Annunciator  
**NCD** Network Control Display  
**NCM-F** Network Communications Module (Fiber)  
**NCM-W** Network Communications Module (Wire)  
**NCO-200** Carbon Monoxide Sensor  
**NCS** Network Control Station  
**N-MPS** MPS Series Pull Station  
**NFV** Notifier FireVoice 25/50  
**NP-200C** PHOTO/CO Detector  
**ONYXWorks®** Workstation Network Monitoring Workstation  
**PRN-6** 80-Column Printer  
**PRN-7** 80-Column Printer  
**R-120** 120 Ohm End-of-Line Resistor  
**R-2.2K** 2.2K End-of-Line Resistor  
**R-27K** 27K End-of-Line Resistor  
**R-470** 470 End-of-Line Resistor  
**R-47K** 47K End-of-Line Resistor

#### Backboxes, Chassis, Dress Panels, etc.

**BF-1B/C** Annunciator Flush Box  
**ABF-1DB/C** Annunciator Flush Box with Door  
**ABF-2B** Annunciator Flush Box  
**ABF-2DB/C** Annunciator Flush Box with Door  
**ABF-4B** Annunciator Flush Box  
**ABM-16AT** Annunciator Blank Module  
**ABM-32A** Annunciator Module Blank  
**ABS-1TB** Annunciator Surface Box  
**ABS-1B/C** Annunciator Surface Box

**RA100Z** Remote Annunciator with diode  
**RA400** Remote Annunciator  
**RPJ-1** Remote Phone Jack  
**RPT-485SF** EIA-485 Repeater (Fiber)  
**RPT-485W** EIA-485 Repeater (Wire)  
**RPT-485WF** EIA-485 Repeater (Wire/Fiber)  
**RM-1** Remote Microphone  
**RM-1SA** Remote Microphone  
**SCS-8, SCE-8** Smoke Control System  
**SDX-551** Intelligent Photoelectric Detector  
**SDX-551TH** Intelligent Photoelectric and Thermal Detector  
**SDX-751** Intelligent Photoelectric Detector  
**SLC-IM** Signaling Line Circuit Integration Module (FlashScan)  
**STS-1** Security Tamper Switch (Not ULC-listed)  
**TM-4** Transmitter Module  
**TR300** Trim Ring White  
**TR300-IV** Trim Ring Ivory  
**UDACT/UDACT-2** Universal Digital Alarm Communicator Transmitter  
**UZC-256** Universal Zone Coder  
**VEP-A00-P-NTF** Addressable VESDA-E VEP with LEDs  
**VEP-A10-P-NTF** Addressable VESDA-E VEP with 3.5" Display  
**VEP-A00-1P-NTF** Addressable VESDA-E VEP 1 Pipe with LEDs  
**VEU-A00-NTF** Addressable VESDA-E VEU with LEDs  
**VEU-A10-NTF** Addressable VESDA-E VEU with 3.5" Display  
**VEA-040-A00-NTF** Addressable VESDA-E VEA-40 point with LEDs  
**VEA-040-A10-NTF** Addressable VESDA-E VEA-40 point with 3.5" Display  
**XPIQ** Quad Intelligent Audio Transponder (Audio Applications)  
**XP10-M** Ten Input Monitor Module  
**XP6-C** Supervised Control Module  
**XP6-MA** Six Zone Interface Module  
**XP6-R** Six Relay Control Module

#### System Sensor Devices

**A2143-00** End of Line Resistor Assembly  
**EOLR-1** End of Line Resistor Assembly

**ABS-1TB/C** Annunciator Surface Box  
**ABS-2B** Annunciator Surface Box  
**ABS-2D/C** Annunciator Surface Box  
**ABS-4D/C** Annunciator Surface Box  
**ABS-8RB** Annunciator Backbox for ACM-8R  
**ADP2-640** Dress Panel: NFS2-640/E in lower row  
**ADP-4B** Annunciator Dress Panel  
**BMP-1** Blank Module Plate  
**BP2-4** Battery Dress Plate

#### Retrofit Equipment: Compatible Notifier Equipment Listed Under Previous Editions of UL 864

NOTE: The products in this list have not received UL 864 9th Edition certification and may only be used in retrofit applications.

✓ **ACM-16AT** Annunciator Control Module  
 ✓ **ACM-32A** Annunciator Control Module  
 ✓ **ACPS-2406** Auxiliary Charger/Power Supply  
 ✓ **AEM-16AT** Annunciator Expander Module  
 ✓ **AEM-32A** Annunciator Expander Module  
 ✓ **AFM-16A** Annunciator Fixed Module  
 ✓ **AFM-32A** Annunciator Fixed Module  
 ✓ **AMG-1/E** Audio Message Generator  
 ✓ **APS-6R** Auxiliary Power Supply  
 ✓ **B501BH/B501BHT** Sounder Base  
 ✓ **BGX-101L** Addressable Manual Pull Station  
 ✓ **CHG-120** Battery Charger  
 ✓ **FCPS-24** Field Charger/Power Supply  
 ✓ **IPX-751** Advanced Multi-Sensor Intelligent Detector

✓ **MMX-1** Addressable Monitor Module  
 ✓ **NCA** Network Communications Annunciator  
 ✓ **PRN-4, PRN-5** 80-Column Printers  
 ✓ **RFX** Wireless Transmitter (version 2.0 and higher)  
 ✓ **SDRF-751** Wireless Photo/Thermal Smoke Detector (*Not ULC-listed*)  
 ✓ **VS4095** Keltron Printer (Dress plate P-40) (*Not ULC-listed*)  
 ✓ **XPIQ** Quad Intelligent Audio Transponder (NAC Applications)  
 ✓ **XP5-C** Transponder Control Module  
 ✓ **XP5-M** Transponder Monitor Module  
 ✓ **XPC-8** Transponder Control Module  
 ✓ **XPM-8** Transponder Monitor Module  
 ✓ **XPM-8L** Transponder Monitor Module  
 ✓ **XPP-1** Transponder Processor  
 ✓ **XPR-8** Transponder Relay Module

**Table 2.1 Notifier Compatible Equipment Chart 3 of 3**

Refer to document 15378, Device Compatibility Document, and document 51253, SLC Signaling Line Circuit Manual, for a list of other devices compatible with this FACP.



**NOTE:** The FWGS Wireless Gateway as part of the wireless network has been tested for compliance with the Federal Communications Commission (FCC) requirements of the United States Government. This product has not been evaluated for use outside the USA. Use of this system outside the USA is subject to local laws and rules to which this product may not conform. It is the sole responsibility of the user to determine if this product may be legally used outside the USA.

## Section 3: Installation

### 3.1 Preparing for Installation

Choose a location for the fire alarm system that is clean, dry, and vibration-free with moderate temperature. The area should be readily accessible with sufficient room to easily install and maintain it. There should be sufficient space for cabinet door(s) to open completely. Carefully unpack the system and inspect for shipping damage. Count the number of conductors needed for all devices and find the appropriate knockouts. (Refer to Section 3.11 “UL Power-limited Wiring Requirements” for selection guidelines.)

Before installing the fire alarm system, read the following:

- Review the installation precautions at the front of this manual, including temperature and humidity limits for the system (Page 3).
- All wiring must comply with the National and Local codes for fire alarm systems.
- Do not draw wiring into the bottom 9 inches (22.86 cm) of the cabinet except when using a separate battery cabinet; this space is for internal battery installation.
- Review installation instructions in Section 3.2 “Installation Checklist”.



**CAUTION:** Make sure to install system components in the sequence listed below. Failure to do so can damage the control panel and other system components.



**WARNING:** This system contains static-sensitive components. Always ground yourself with a proper wrist strap before handling any circuits. Use static-suppressive packaging to protect electronic assemblies removed from the unit.

#### 3.1.1 Standards and Codes

In addition, installers should be familiar with the following standards and codes:

- NEC Article 300 Wiring Methods.
- NEC Article 760 Fire Protective Signaling Systems.
- Applicable Local and State Building Codes.
- Requirements of the Local Authority Having Jurisdiction.
- C22.1-98 The Canadian Electrical Code, Part 1.
- CAN/ULC-S5524-01 Standard for the Installation of Fire Alarm Systems.

## 3.2 Installation Checklist

Table 3.1 provides an installation checklist for installing, wiring, and testing the NFS2-640/E system. It has references to installation information included in manuals listed in Section 1.3 “Related Documents”.

Seq	Task	Refer to
1.	Mount the cabinet backbox to the wall.	Section 3.3 “Mounting a Cabinet”
2.	Install hinges for door	<i>CAB-3/CAB-4 Series Cabinet Installation Document</i>
3.	Install all required chassis in cabinet.	Section 3.5 “Installing the Control Panel”
4.	Install control panel onto chassis.	Section 3.5.1 “Control Panel Circuit Board & Keypad/Display Unit”
5.	Optional: Install auxiliary power supply and/or external battery charger	Auxiliary power manuals
6.	Connect AC wiring, place batteries into backbox without connecting them, and run cable to optional power supplies, DC power outputs, NACs, and relays. <b>CAUTION: Do not apply AC or DC power at this time.</b>	Section 3.7 “Connecting the Power Cables”
7.	Set switches for backup alarm (SW1-SW4).	Section 3.10 “Backup-Alarm Switches”
8.	Optional: Install option boards, annunciators, network equipment, and Audio components	Section 3.6, “Mounting Option Boards”, the relevant annunciator/network-card manual, <i>DVC Manual</i> , and <i>DVC-RPU Manual</i> .
9.	Optional: Install output devices such as a printer, or CRT terminal.	Section 3.13 “Installing Remote Printers and/or CRT”
10.	Optional: Install NCA-2, NCD, NCS or ONYXWorks.	<i>NCA-2 Manual</i> , <i>NCD Manual</i> , <i>NCS Manual</i> or <i>ONYXWorks Manual</i>
11.	Secure any unused mounting holes in control panel circuit board.	Figure 3.8
12.	Wire the Signaling Line Circuits.	Section 3.14 “Wiring a Signaling Line Circuit (SLC)”
13.	Terminate wire shielding as instructed.	SLC Wiring Manual
14.	Apply AC power to the control panel by placing the external circuit breaker to the ON position. Do NOT connect batteries.	
15.	Check AC power.	Table 3.5 in Section 3.7 “Connecting the Power Cables”
16.	Connect the batteries using interconnect cable, P/N 75560 and 75561.	
17.	Install the CAB-4 series door.	<i>CAB-3/CAB-4 Series Cabinet Installation Document</i>
18.	Program the control panel.	<i>NFS2-640/E Programming Manual</i>
19.	Field test the system.	Section 5 “Testing the System”

**Table 3.1 Installation Checklist**

## 3.3 Mounting a Cabinet

This section provides instructions for mounting a CAB-4 Series backbox to a wall. Follow these guidelines when mounting the backbox:

- Locate the backbox so that the top edge is 66 inches (1.6764 m) above the surface of the finished floor.
- Access to the cabinet shall be provided in accordance with NFPA 90, article 110.33.
- Allow sufficient clearance around cabinet for door to swing freely. (See Section 2.3 “System Cabinets”.)
- Use the four holes in the back surface of the backbox to provide secure mounting. (See Figure 3.1.)
- Mount the backbox on a surface that is in a clean, dry, vibration-free area.



**CAUTION:** Unless you are familiar with the placement of components within this backbox, only use the knockout locations provided for conduit entry.

Follow the instructions below.

1. Mark and pre-drill holes for the top two keyhole mounting bolts (0.25 inch, 0.635 cm). Use mounting hardware appropriate for the mounting surfaces and weight of loaded cabinet; see UL 2017 Pull-Test Requirements.
2. Select and punch open the appropriate knock-outs. (For selection guidelines, see Section 3.11 “UL Power-limited Wiring Requirements”.)
3. Using the keyholes, mount the backbox over the two screws.
4. Mark the location for the two lower holes, remove the backbox and drill the mounting holes.
5. Mount the backbox over the top two screws, then install the remaining fasteners. Tighten all fasteners securely.
6. Feed wires through appropriate knockouts.

7. Install control panel and other components according to Section 3.5 “Installing the Control Panel” before installing hinges and door according to *CAB-3/CAB-4 Series Cabinet Installation Document*.

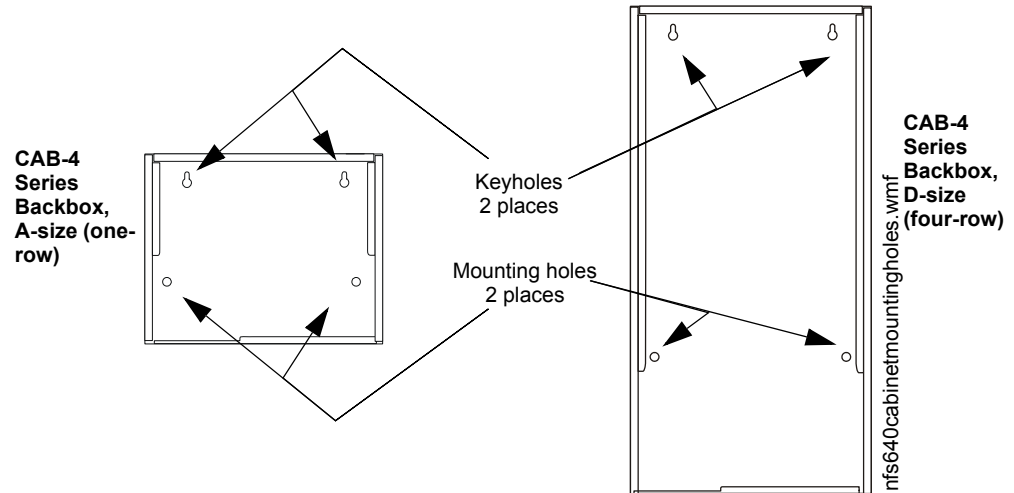


Figure 3.1 Mounting Holes of a Backbox

### 3.4 Laying Out Equipment in Cabinet and Chassis

The NFS2-640/E allows for flexible system design. Backboxes are available to hold up to four rows of equipment (four chassis), plus batteries. Each chassis has four “slots” -- the basic positions available side by side on a chassis. The number of modules that can be mounted in each position depends on the chassis model and the module size.

Follow these guidelines when deciding where to locate equipment in the backbox.

The NFS2-640/E control panel and adjacent first-row modules mount in the NFS2-640 chassis, typically installed in the first/top row of the backbox behind DP-DISP2. (Use ADP2-640 if mounting NFS2-640 chassis in a lower row.) NFS2-640 chassis holds four layers of equipment, including the control panel. See Figure 3.3. The primary display (KDM-R2, NCD or NCA-2) mounts in front of NFS2-640/E.

The CPU mounts in the NFS2-640 chassis behind DP-DISP2 (top row) or ADP2-640 (lower row). The control panel fills three positions in the first-installed layer against the chassis; its power supply occupies two positions on top of the control panel; and the optional display occupies two positions in the fourth layer (flush with the dress panel).

Mount second, third, or fourth rows of equipment in other compatible chassis, such as chassis CHS-4L, CA-1, or CA-2. (See Table 3.3, “Chassis Compatibility,” on page 23.) For details on audio equipment see the *DVC Manual*.

Option boards use standard mounting hole positions to allow them to be mounted in various locations and layers, depending on the desired system configuration. (See Table 3.2 to determine hardware.) Some equipment such as annunciators may be mounted on a dress panel directly in front of the control panel. The BMP-1 Blank Module Plate covers unused positions in a dress-panel, also providing an additional mounting location for some option boards, such as TM-4 (see *BMP-1 Product Installation Drawing* for details).

Annunciators can be mounted in dress panels such as ADP-4B; one or two annunciators can be installed in the DP-DISP2 or ADP2-640 with the control panel. Installing the BMP-1 blank plate in these dress panels provides an additional mounting location for option boards. Refer to the equipment’s documentation for details.

Install BP2-4 Battery Plate in front of the battery compartment in NFS2-640/E installations and provides Protected Premises Unit labels.

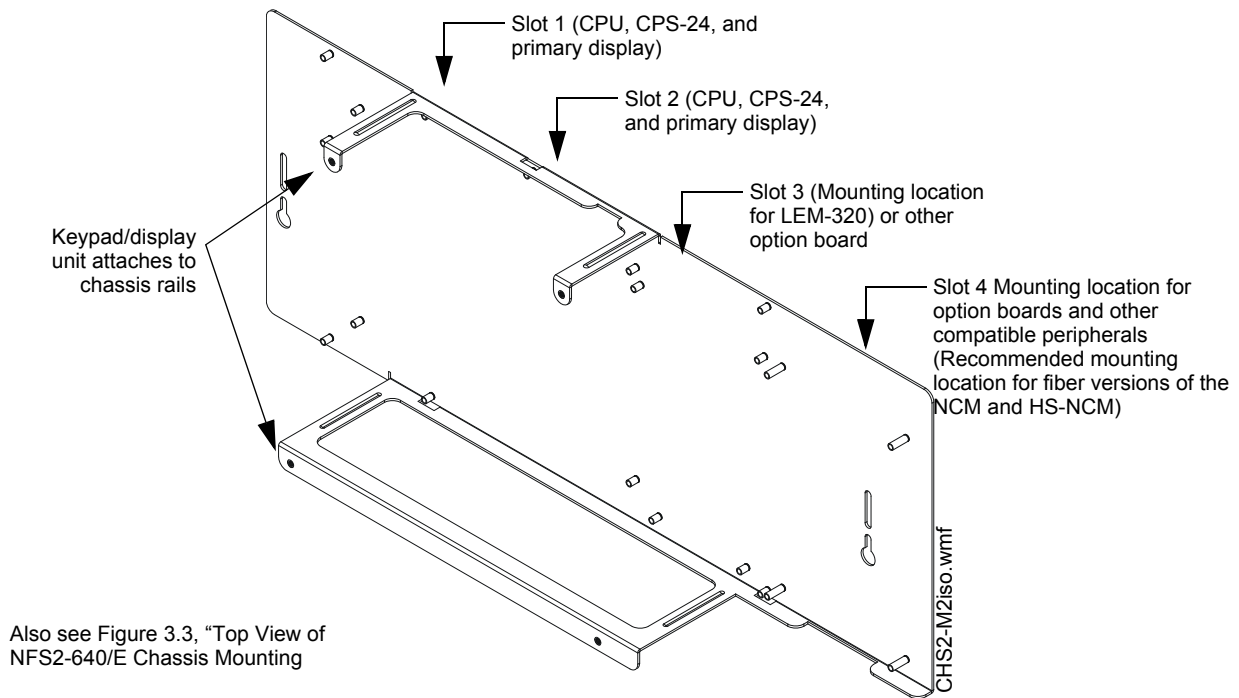


**NOTE:** The BP2-4 is required for NFS2-640/E installations due to UL’s revised labeling requirements. If using NFS2-640/E in retrofits, order BP2-4 to replace previous BP-4 battery dress panels.

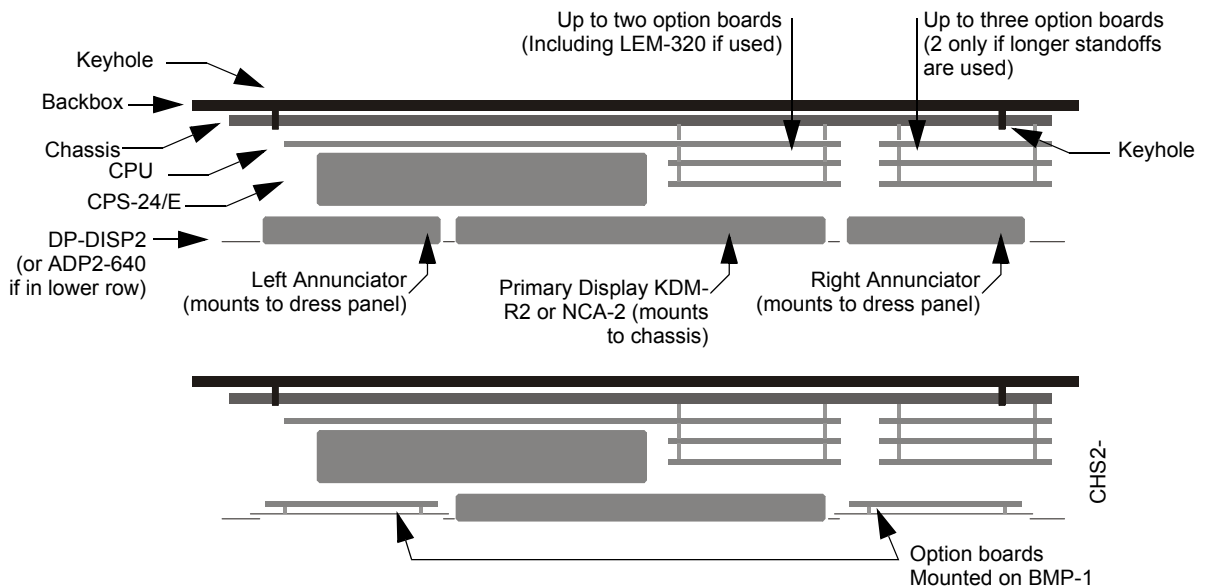
If DP-DISP2 is not being used in the top row of the backbox, install VP-2B above the first row to cover the remaining space.



**NOTE:** When designing the cabinet layout, consider separation of power-limited and non-power-limited wiring as discussed in Section 3.11 "UL Power-limited Wiring Requirements."



**Figure 3.2 Side View of the NFS2-640/E Chassis Mounting Options**



**Figure 3.3 Top View of NFS2-640/E Chassis Mounting Options**

When installing the Network Control Display (NCD) into the NFS2-640 chassis, it can only be left mounted because of the position of the grounding screw.

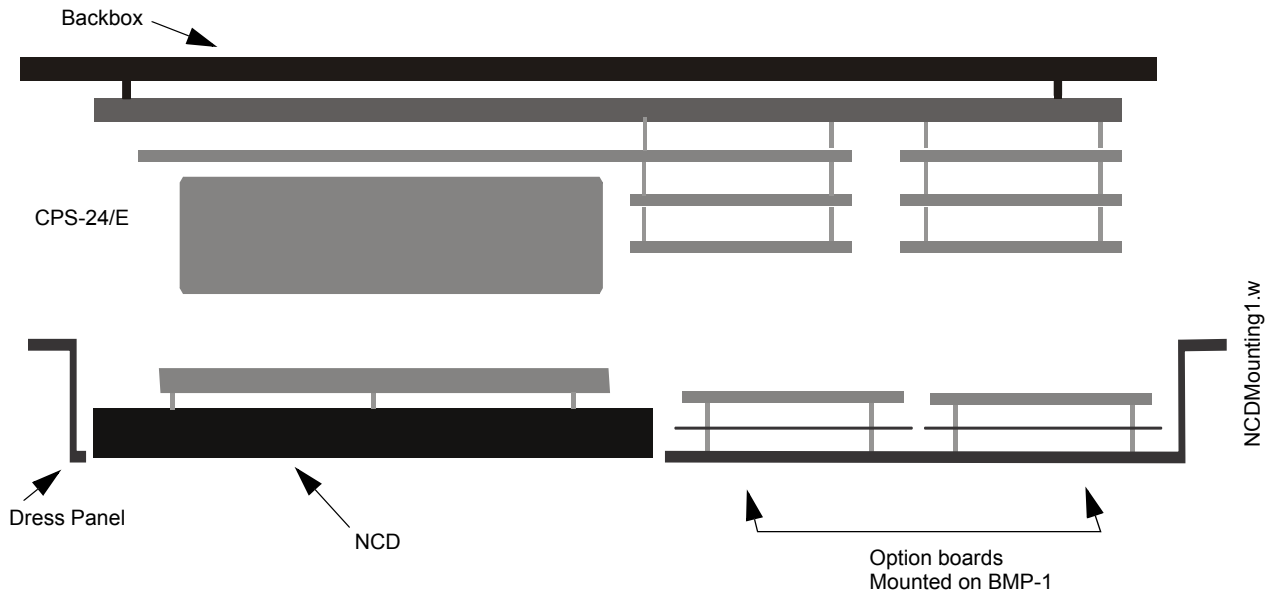


Figure 3.4 Top View of Mounting an NCD in the NFS2-640 Chassis

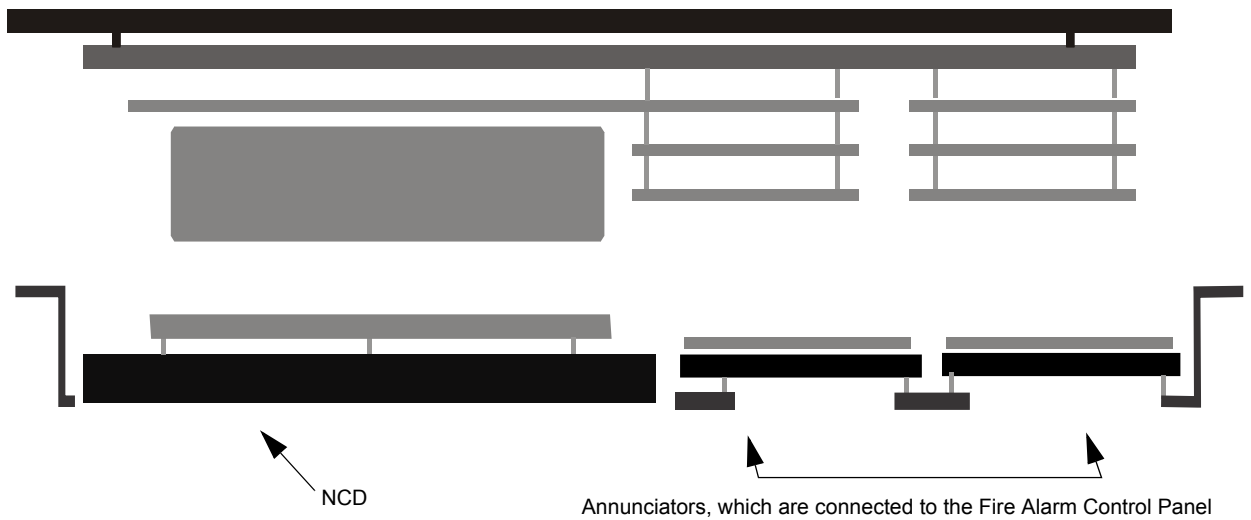


Figure 3.5 Top View of Mounting an NCD with Annunciators



**NOTE:** See the NCD Manual LS10210-051NF-E for more information.

From...	To...	Required Stand-off or Hardware
NFS2-640/E chassis	Control panel or option board on first layer	Attaches directly to chassis.
NFS2-640/E chassis	Keypad/display unit	Attaches directly to chassis rails.
NFS2-640/E chassis	NCA-2, NCD	Attaches directly to chassis rails with mounting hardware NCA/640-2-KIT (ordered separately)
Control panel (third slot)	Any option board in third slot (such as LEM-320)	4 male-female stand-offs 1 inch (25.4 mm) P/N 42118; installed and shipped with CPU2-640/CPU2-640E.
Option board or NFS2-640/E chassis (fourth slot)	Option board in next layer (not including LEM-320)	4 male-female stand-offs either 1.5 inch (38.1 mm) P/N 42175 or 0.937 inch (23.8 mm) P/N 42166, both shipped with option boards. Choose stand-off length that allows space for your option board's connectors; using longer stand-offs may reduce the number of option boards that fit in the chassis position.
Chassis or Dress Panel	Annunciator	Attaches directly to dress panels or attaches to flanges on chassis CHS-4/4N. (Screws provided with annunciator.)
Dress panels DP-DISP2, ADP2-640, ADP-4B	Option board	BMP-1 attaches to dress panel; option module attaches to BMP-1. (Screws provided with option module). See Figure 3.9.
Dress panel ADP-4B	NCA-2	Use "NCA-2 RETRO kit" hardware if mounting NCA-2 to a dress panel; cannot be mounted in front of the NFS2-640/E chassis.

Table 3.2 Stand-off Lengths

Product	Chassis/Door-mounting options
NFS2-640/E	<ul style="list-style-type: none"> <li>NFS2-640/E chassis</li> </ul>
NCA-2, NCD	<ul style="list-style-type: none"> <li>CHS-M2, NFS2-640/E chassis, CHS-M3</li> <li>CA-2; requires two rows in the backbox</li> </ul>
DVC	<ul style="list-style-type: none"> <li>CA-1</li> <li>CA-2</li> </ul>
DVC-RPU	<ul style="list-style-type: none"> <li>CA-1</li> </ul>
DAA	<ul style="list-style-type: none"> <li>Factory-mounted in its own chassis.</li> </ul>
Analogue audio amplifiers AA-30, AA-100, AA-120	<ul style="list-style-type: none"> <li>Mounts directly onto CAB-4 backbox</li> </ul>
Option boards	<ul style="list-style-type: none"> <li>NFS2-640/E chassis, CHS-4, CHS-4L, CHS-4N (shipped as part of kit CHS-4MB), or on BMP-1 inside dress plate</li> <li>Note: Mount LEM-320 in front of CPU2-640 in the NFS2-640/E chassis.</li> <li>Note: Mount UDACT/UDACT-2 in second or lower row, or in slot 4 of the NFS2-640/E chassis with nothing in front of it.</li> <li>Note: Mount fiber versions of the NCM and HS-NCM in the top row under knockouts, to avoid excessive bend on the fiber-optic cable.</li> </ul>
ACS series annunciators ACM-24AT, ACM-48A and expanders	<ul style="list-style-type: none"> <li>Dress Panel DP-DISP2, ADP2-640, or ADP-4B</li> </ul>

Table 3.3 Chassis Compatibility



**NOTE:** In retrofit applications, the CAB-e series backbox may be used, but order BP2-4 to replace previous BP-4 battery dress panels.

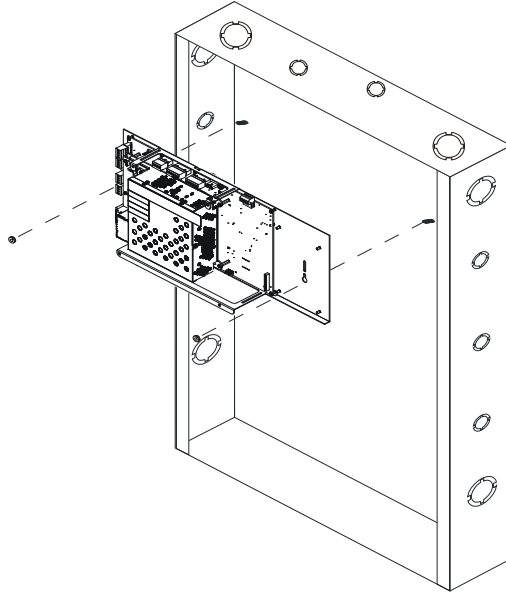
Chassis/Dress plate	Typical Backbox Location(s) in CAB-4 Backboxes
NFS2-640/E chassis	Top row of backbox typical; lower rows also possible.
CA-1	Second or lower row of backbox
CA-2	Requires two rows of backbox
CHS-4, CHS-4L, CHS-4N	Second or lower row of backbox
DPA-2 Dress Panel	Mounts in front of CA-2 covering two rows of the backbox
DP-DISP2 Dress Panel	Mounts in front of the NFS2-640/E chassis in top row of backbox
ADP2-640 Dress Panel	Mounts in front of NFS2-640/E chassis in second or lower row of backbox
ADP-4B Dress Panel	Mounts in front of any chassis

Table 3.4 Chassis Locations in CAB-4 Backboxes

## 3.5 Installing the Control Panel

### 3.5.1 Control Panel Circuit Board & Keypad/Display Unit

The control panel comes pre-mounted in the NFS2-640/E chassis, which is usually positioned in the top row of the backbox. The control panel's CPU occupies three positions at the back of the chassis; the KDM-R2 occupies three positions flush with the dress panel. The NCA-2 may be mounted directly in front of the control panel if no KDM-R2 is being used; use NCA/640-2-KIT as described in the *NCA-2 Installation Manual*.



**Figure 3.6 NFS2-640/E Chassis Mounting**

Perform the following steps when installing the NFS2-640/E:

1. Screw chassis to the backbox.†
2. If installing KDM-R2 as primary display:
  - Attach ribbon cable from keypad to J7 connector on control panel. (See Figure 2.2.)
  - Align the keypad with the mounting holes as shown in Figure 3.8 and screw it down.
3. If installing the NCA-2 as primary display: Secure it to the NFS2-640/E chassis with NCA/640-2-KIT as described in the *NCA-2 Manual*.
4. If installing option boards, do so as described in Section 3.6, “Mounting Option Boards”. If NFS2-640/E is being installed into an older backbox, two additional steps must be taken:
5. Battery Plate BP-4 must be replaced with BP2-4, per UL’s revised labeling requirements.
6. The older door and dress panel must be replaced with equipment compatible with KDM-R2.

†If the NFS2-640/E chassis is not assembled as when shipped, attach CPU2-640 to the chassis. Slide control-panel tabs into slots on chassis and lay the board onto stand-offs so that mounting holes line up with those on the chassis. Secure with six screws and four 1 inch stand-offs as shown in Figure 3.7, “Mounting KDM-R2”.



**CAUTION:** It is critical that all mounting holes of the NFS2-640/E are secured with a screw or standoff to insure continuity of Earth Ground.



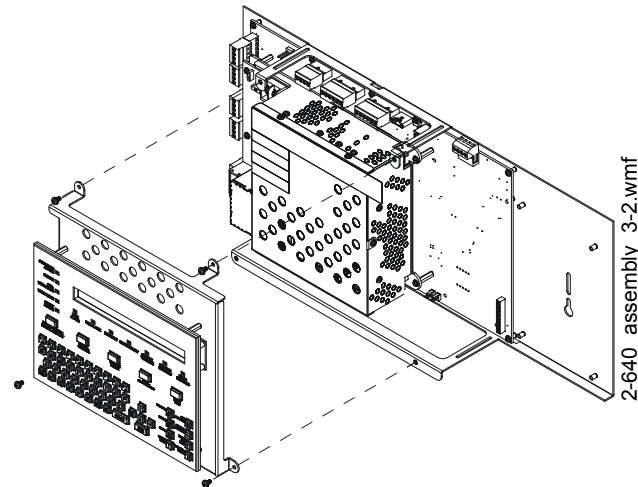


Figure 3.7 Mounting KDM-R2

### 3.5.2 Using NCA-2 as Primary Display

The NFS2-640/E can be set up to use the NCA-2 as the primary display. In this system design, mount NCA-2 to the NFS2-640/E chassis in front of CPS-24/E, and connect the network/service port on the NFS2-640/E (J1) directly to the network/service port on the NCA-2 (J3). See the *NCA-2 Manual* for specific instructions.



**NOTE:** This system design is required in Canadian stand-alone applications.

If the NFS2-640/E and NCA-2 are being used as a stand-alone pair, each device must be programmed using VeriFire Tools. Connect the VeriFire Tools PC to NFS2-640/E using USB B Port J3 and program as described in VeriFire Tools on-line help.

For older PCs without USB connectors, NFS2-640/E and NCA-2 must be temporarily disconnected and separately programmed, because VeriFire Tools also uses the network/service port. Follow VeriFire Tools instructions for off-line programming mode.

If the NFS2-640/E with NCA-2 is connected to a network, there are two additional options for programming: either connect the VeriFire Tools programming PC to the network port on the NCM/HS-NCM board, or program the NFS2-640/E through another network node.



**NOTE:** This is the only NCA-2 application that does not require an NCM or HS-NCM connection to Noti•Fire•Net.

### 3.5.3 Using the NCD as Primary Display on the NFS2-640

The NCD can be directly connected to the NUP port of the CPU2-640.

The NFS2-640/E can be set up to use the NCD as the primary display.

When the NCD is used as the primary display, the KDM-R2 needs to be removed.

When using the NCD as an alternate display for the NFS2-640 on a standard Noti•Fire•Net, the panel becomes standalone and is not networkable, since there is only one NUP port available on the NCM. If the panel is on a High-Speed Noti•Fire•Net, the panel can be networked using the second NUP available on the HS-NCM. The NCD can only be mounted on the left side of the DP-GDIS1 dress plate. Refer to the NCD manual LS10210-051NF-E for more information.

## 3.6 Mounting Option Boards

If installing option boards into a CAB-4 Series backbox, mount and connect those boards at this time. General instructions follow; the sections about individual option boards contain any module-specific instructions such as mounting LEM-320's stacker-connector.

### 3.6.1 Option Boards in the NFS2-640/E Chassis

Mount option boards in slots 3 and 4 of the NFS2-640/E chassis. (See Figure 3.2, Figure 3.8, and Figure 3.9.) For standoff lengths, see Table 3.2.



**NOTE:** Another option board can be mounted above a Loop Expander Module or Network Communications Module; for ease of access, be sure to complete installation of those devices before mounting a second layer.



**NOTE:** If using the fourth (right-side) position of the NFS2-640/E chassis, the chassis needs to be installed on the backbox before option boards or modules are installed in that position. These modules will block access to the keyhole opening.

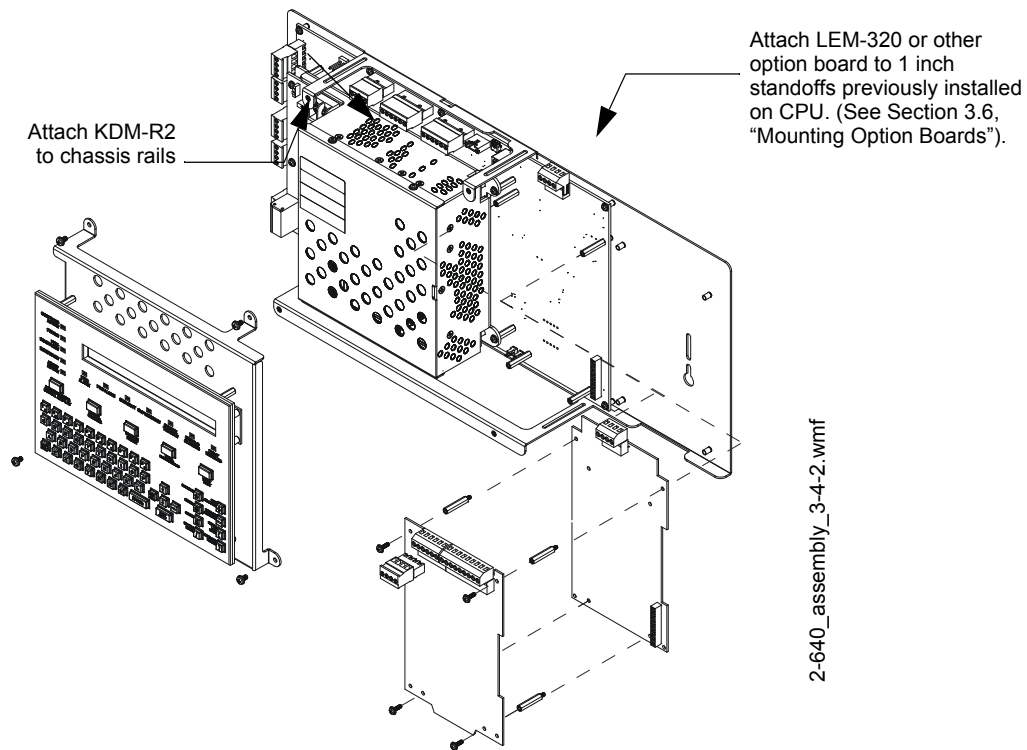


Figure 3.8 Attaching Option Boards Behind KDM-R2

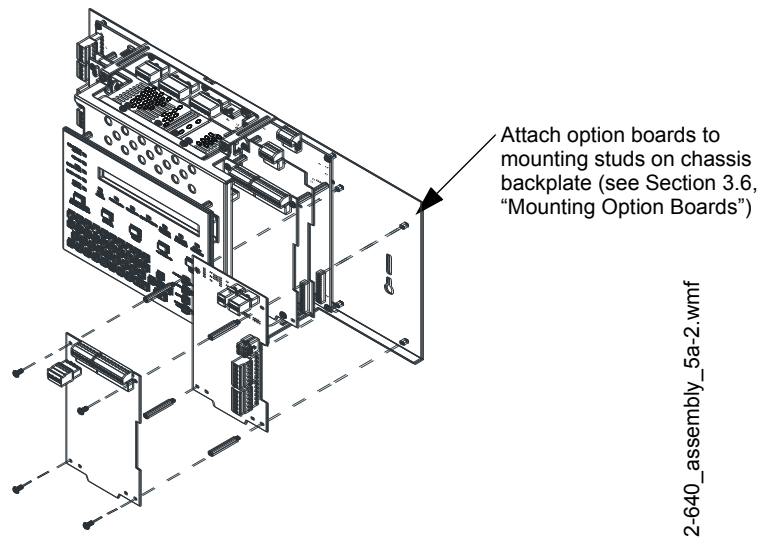


Figure 3.9 Attaching Option Boards to the Right of the CPU

### 3.6.2 Option Boards in CHS-4L

1. Slide the tabs at the bottom of the option board into slots on the chassis as shown in Figure 3.11.
2. Lay the board back onto the flanges so that the studs line up with mounting holes on the option board.
3. Attach the option board using screws provided with the board, or if installing a second option board, with stand-offs provided with the second board.

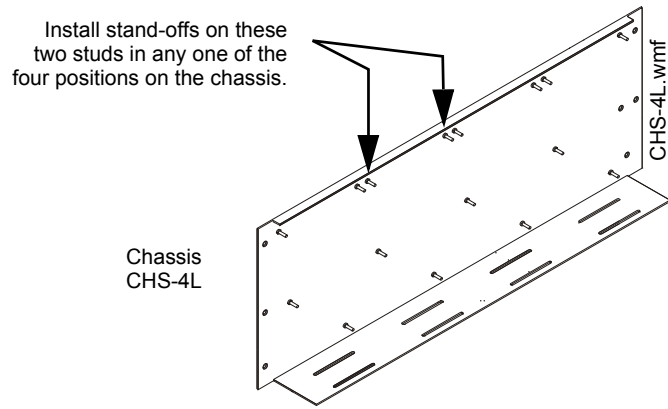


Figure 3.10 Standoff Locations on CHS-4L

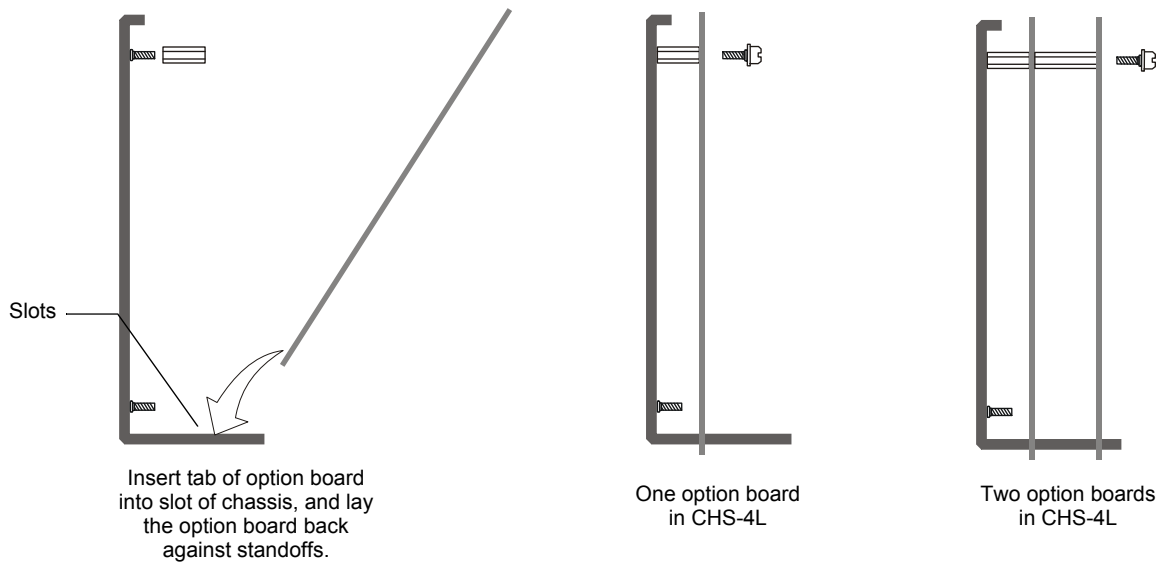


Figure 3.11 Mounting an Option Board in a Chassis (CHS-4L Shown)

### 3.6.3 Option Boards on BMP-1 in Dress Panels

Option boards can be mounted on BMP-1 blank module plate, inside dress panels such as DP-DISP2, ADP2-640, ADP-4B, as shown in Figure 3.12.

Mount BMP-1 onto compatible dress panel or backbox trim ring

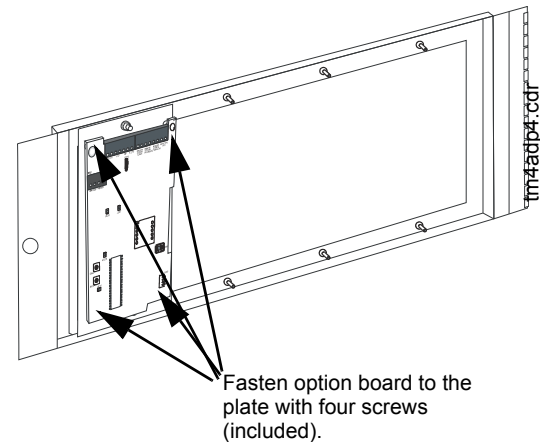
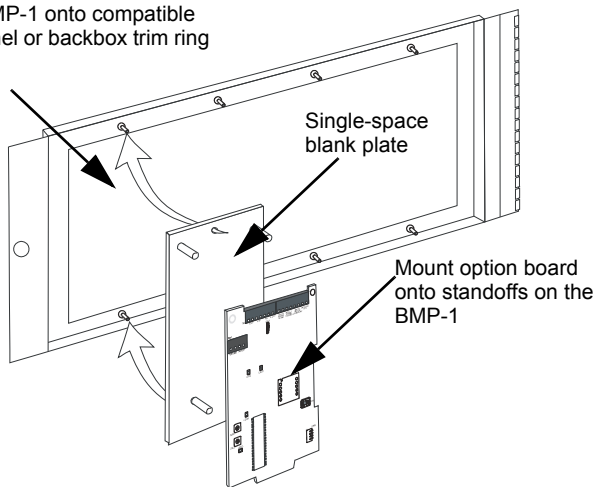


Figure 3.12 Mounting an Option Board onto a Dress Panel with BMP-1 (ADP-4B Shown)



**NOTE:** See the *BMP-1 Product Installation Drawing* for details if considering mounting the module behind blank module plate in a dress plate or annunciator backbox. This dress plate is suitable for modules that do not need to be visible or accessible when the door is closed.

### 3.6.4 Transmitter Module TM-4

TM-4 is power-limited. Connections are on TB10 nonresettable output and TB11 EIA-485 ACS Mode. Refer to the *Transmitter Module TM-4* installation document for installation details.

### 3.6.5 Loop Expander Module

Installing a Loop Expander Module adds a second SLC loop to the control panel. Refer to Figure 3.14 for stacker-connector illustrations.

1. Plug short end of the stacker-connector into J4 on the CPU2-640.
2. Align the LEM with the four 1 inch standoffs and the stacker-connector as shown in Figure 3.14; firmly seat the stacker-connector.
3. Attach LEM to standoffs using screws or another set of standoffs.
4. After LEM is mounted on the control panel, connect the SLC loops to TB1 on the LEM and TB13 on the CPU2-640. This system supports either FlashScan or CLIP mode devices. Refer to the SLC loop manual for wiring requirements and specific details.

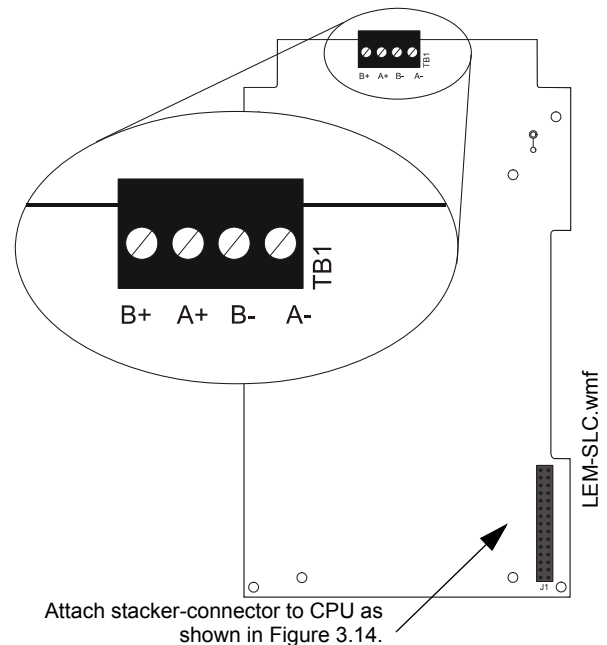


Figure 3.13 SLC Connections for LEM-320



**CAUTION:** For the SLC to function correctly, the stacker-connector must be installed as shown in Figure 3.14. **Do not install other option modules on top of the LEM-320.**

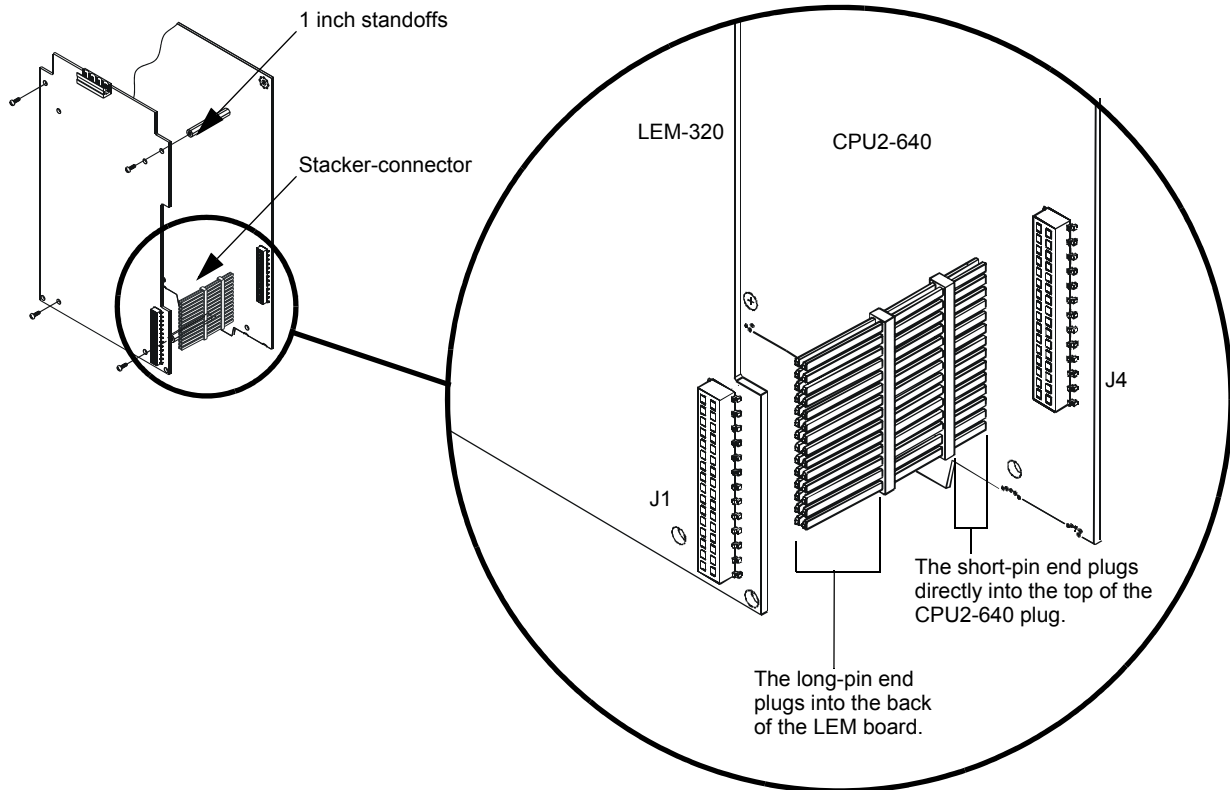


Figure 3.14 Mounting LEM-320 with the Stacker-connector

### 3.6.6 Network Communications Module

If networking two or more control panels or network control annunciators, each unit requires a Network Communications Module (NCM) or a High-Speed Network Communications Module (HS-NCM); wire and fiber versions of each are available. The wire and/or fiber versions of the NCM or the HS-NCM can be installed in any standard option-board position (see Section 3.6 “Mounting Option Boards”); the default position is immediately to the right of the control panel.

Mount the NCM/HS-NCM in the selected position and screw in place firmly.

Connect J1 on the control panel to J3 on the NCM or J6 of the HS-NCM using the network cable provided (P/N 75556) as described in the *NCM Installation Document* and the *HS-NCM Installation Document*. Do not connect two NCM/HS-NCMs via NUP ports (aka NUP to NUP).

**When installing the NCM:** Connect Channel A and/or Channel B as described in the *NCM Installation Document*.

**When installing the HS-NCM:** Connect Channel A to Channel B as described in the *HS-NCM Installation Document*



**NOTE:** See the *Noti•Fire•Net Manual* or the *High-Speed Noti•Fire•Net Manual* and NCM Installation Document or *HS-NCM Installation Document* for wiring diagrams and system configuration information. See the BMP-1 Product Installation Drawing if considering mounting the module behind blank module plate in a dress plate or annunciator backbox.



**NOTE:** Over-bending fiber-optic cable can damage it. Do not exceed a 3 inch (7.62 cm) minimum bend radius.



**NOTE:** NCM hardware is not compatible with HS-NCM hardware and should not be mixed on the same network.

### 3.6.7 DVC Digital Voice Command

Each DVC Series model is a multi-featured audio processor with digital audio functionality that operates as an event-driven audio message generator and router. It is designed for use with the DAA2, DAX, DAA Series digital audio amplifiers, and the DVC-RPU Remote Paging Unit, as well as the DS-DB distribution boards, in a single panel or networked environment, and may also be used as an analog audio source or configured as a remote paging unit. Refer to the *DVC Manual* and *DVC-RPU Manual*.

The NFS2-640/E may be directly connected to the DVC for single panel applications. An associated NCA-2 is required when a DAL (digital audio loop) is part of the configuration; this configuration supports NUP-to-NUP-to-NUP configuration for single panel DAL applications.

Network configurations require an associated NCA-2, and will support all Network Control-by-Event; each node (DVC, CPU-2 and NCA-2) requires a network address/NCM port in network applications.



**NOTE:** The DVC Series consists of all the model versions listed in the bullets below this note. Individual part numbers are used in this manual only when it is necessary to distinguish features or functions that differ. The term DVC is used in all other cases.

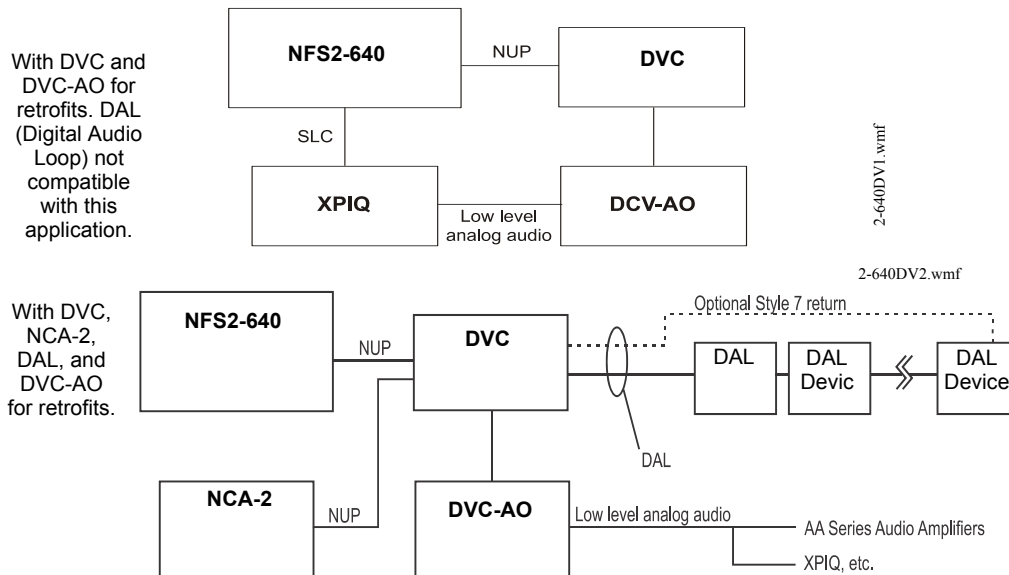
- DVC-EM - Digital Voice Command, extended memory, wire version (standard)
- DVC-EMF - Digital Voice Command, extended memory, multi-mode fiber version
- DVC-EMSF - Digital Voice Command, extended memory, single-mode fiber version.

For information regarding audio storage for the DVC-EM Series models listed above, refer to the *DVC Digital Voice Command Manual*.



**NOTE:** The term DAA is used in this manual to refer to all DAA wire and fiber models. Individual part numbers are used only when it is necessary to distinguish features or functions that differ.

Figure 3.15 gives simplified overview illustrations of typical applications for the DVC Series and its Digital Audio Loop (DAL). Wire and fiber, or multi-mode and single-mode, can be mixed.



**Figure 3.15 Block Diagrams of DVC Series Applications**

### 3.7 Connecting the Power Cables



**WARNING:**

REMOVE ALL POWER SOURCES TO EQUIPMENT WHILE CONNECTING ELECTRICAL COMPONENTS. LEAVE THE EXTERNAL, MAIN POWER BREAKER OFF UNTIL INSTALLATION OF THE ENTIRE SYSTEM IS COMPLETE.



**WARNING:**

SEVERAL SOURCES OF POWER CAN BE CONNECTED TO THE CONTROL PANEL. BEFORE SERVICING THE CONTROL PANEL, DISCONNECT ALL SOURCES OF INPUT POWER INCLUDING THE BATTERY. WHILE ENERGIZED, THE CONTROL PANEL AND ASSOCIATED EQUIPMENT CAN BE DAMAGED BY REMOVING AND/OR INSERTING CARDS, MODULES, OR INTERCONNECTING CABLES.

#### 3.7.1 Overview

Complete all mounting procedures and check all wiring before applying power. Electrical connections include the following:

- Primary AC power source – 120 VAC, 50/60 Hz, 5.0 A (with NFS2-640E use 240 VAC, 50/60 Hz, 2.5 A) from line voltage source. Overcurrent protection for this circuit must comply with Article 760 of the National Electrical Code (NEC) and/or local codes. Use 12 AWG (3.31 mm<sup>2</sup>) wire (maximum) with a 600-volt rating.
- Secondary power source – 24 VDC from batteries, installed in the control panel (or in an optional battery cabinet). Secondary (battery) power is required to support the system during loss of primary power.
- External power sources – 24 VDC power for Smoke Detectors (4 wire), NACs, and Annunciators.
- Auxiliary power source – 24 VDC power @ 0.5 A and 5 VDC power @ 0.15 A from TB2 on the CPS-24/E.

See Appendix B.1 “Electrical Specifications” for details and overall installation guidelines.

### 3.7.2 Connecting the Control Panel to AC Power

Connect primary power as follows (see Figure 3.16):

1. Turn off the circuit breaker at the main power distribution panel.
2. Open the hinged insulating cover on TB1.
3. Connect the service ground to terminal marked Ground (Earth).
4. Connect the primary neutral line to terminal marked NEUTRAL and the primary Hot line to terminal marked HOT.
5. Close the hinged insulating cover over TB1.

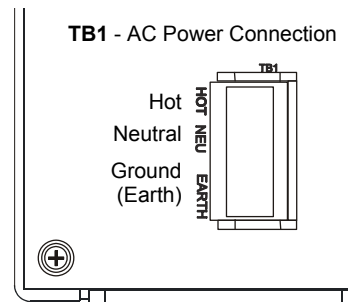


Figure 3.16 CPS-24/E: AC Power Connections

### 3.7.3 Checking AC Power

Table 3.5 contains a checklist for checking the system with AC power applied:



**CAUTION:**

While checking AC power, make sure batteries are not connected. Follow the sequence of steps in Section 3.2 “Installation Checklist”, Table 3.1; this is Step 15.

Component	Status
Control panel circuit board	The green AC Power indicator on; the system Trouble indicator on because batteries are not connected.
Each option board	The yellow Trouble indicator may come on for approximately 10 seconds after applying AC power. (This only applies to an unconfigured system.)
Each auxiliary power supply	The yellow Trouble indicator comes on because batteries are not connected.

Table 3.5 AC Power Checklist

### 3.7.4 Installing and Connecting the Batteries



**WARNING:**

BATTERY CONTAINS SULFURIC ACID WHICH CAN CAUSE SEVERE BURNS TO THE SKIN AND EYES, AND CAN DESTROY FABRICS. IF CONTACT IS MADE WITH SULFURIC ACID, IMMEDIATELY FLUSH SKIN OR EYES WITH WATER FOR 15 MINUTES AND SEEK IMMEDIATE MEDICAL ATTENTION.



**WARNING:**

DO NOT CONNECT THE BATTERY INTERCONNECT CABLES (P/N 75560 AND 75561) AT THIS TIME. MAKE THIS CONNECTION AFTER INITIAL SYSTEM PRIMARY POWER UP. FOLLOW SEQUENCE OF STEPS IN SECTION 3.2 “INSTALLATION CHECKLIST”, TABLE 3.1; THIS IS STEP 16.

Batteries are installed in the control panel cabinet or in a separate battery cabinet which can be mounted below the control panel or up to 20 feet (6.096 m) away from the control panel, in conduit in the same room.

Connect the battery as follows (see Figure 3.16 above):

1. Install batteries into bottom of cabinet or into separate battery cabinet.
2. Connect the red cable from TB3(+) on the CPS-24/E power supply to the positive (+) terminal of one battery.
3. Connect the black cable from TB3(-) on the CPS-24/E power supply to the negative (-) terminal of the **other** battery.
4. Connect the remaining cable between the negative (-) terminal on the first battery to the positive (+) terminal on the second battery.

TB3 - Battery Connection

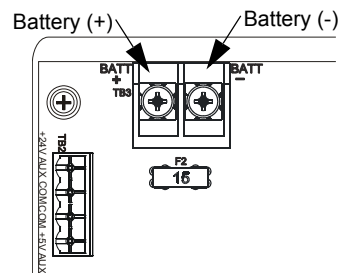


Figure 3.17 CPS-24/E: DC Power Connections



### 3.7.5 External DC Power Output Connections

Terminal TB10 provides two (2) power outputs, resettable and non-resettable. Each output is power-limited, Class B wiring. Supervise with a power supervision relay EOLR-1. Follow sequence of steps in Section 3.2 "Installation Checklist", Table 3.1; this is part of Step 6. TB2 (on CPS-24), TB10 and all 4 NACS share a maximum of 3.0 A in standby and 6.0 A in alarm.

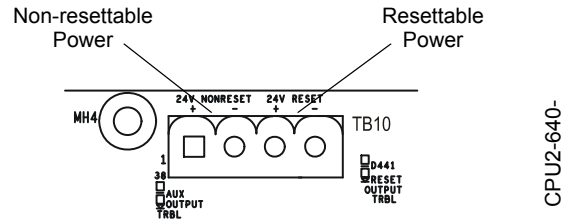


Figure 3.18 Power Supply DC Outputs - TB10

**24 VDC Resettable Power Circuit (Four-Wire Smoke Detectors).** The power supply provides a single 24 VDC filtered, power-limited, resettable power circuit for devices that require resettable power (such as four-wire smoke detectors). This circuit is power-limited, but must be supervised. To provide supervision, install a UL-listed end-of-line power supervision relay (such as the System Sensor model EOLR-1) after the last device. Connect the power supervision relay normally open contact in series with an Initiating Device Circuit (IDC). The four-wire power circuit energizes the power supervision relay. When you reset the system, the control panel removes power from these terminals for approximately 15 seconds.

Connect external field wires to the power supply terminals TB10 RESET(+) and (-) to provide up to 1.25 A of current for powering four-wire smoke detectors. 1.5 A max for special applications. The total current drawn from the power supply by TB2, TB6 through TB9 and TB10 cannot exceed 3.0 A in standby or 6.0 A in an alarm condition. The Control Panel provides a total of 4.4 A of power in standby and 7.4 A of power in alarm to be shared by all internal circuitry and external provisions (24 V

resettable and non-resettable). See Figure 3.18 above. TB2 (on CPS-24), TB10 and all 4 NACS share a maximum of 3.0 A in standby and 6.0 A in alarm.

**24 VDC Non-resettable Power Circuit** The power supply provides one 24 VDC filtered, power-limited, non-resettable power output, capable of up to 1.25 A. Use this circuit to power devices that require low-noise 24 VDC power (such as annunciator model ACM-24AT or the transmitter module TM-4).

Connect external field wires to power supply terminals TB10 NONRESET(+) and (-) to provide up to 1.25 A of non-resettable current for powering external devices such as annunciators. See Figure 3.18 above. TB2 (on CPS-24), TB10 and all 4 NACS share a maximum of 3.0 A in standby and 6.0 A in alarm.



**CAUTION:**

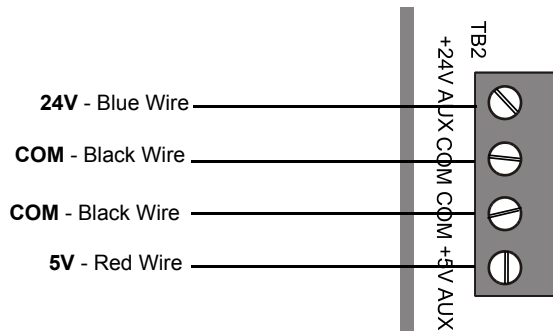
DURING SYSTEM RESET, POWER REMAINS AT TERMINALS TB10 NONRESET(+) AND (-).

### 3.7.6 Accessories DC Power Output Connections

Terminal TB2 supplies one (1) non-resettable, power-limited 24 VDC circuit and one non-resettable, power-limited 5 VDC circuit available to power external devices. Class B wiring is possible. Supervise with a power supervision relay EOLR-1. Applications that require a 5V connection to the Accessories Output, such as an UZC-256, must be within 10 feet (3.658 meters) of the power supply. The distance from the power supply to the accessory requiring power must not extend past the length of the supplied cable, P/N 75657 (supplied with UZC-256), which is 10 feet long. Do not splice or otherwise extend P/N 75657. Refer to section B.2, "Wire Requirements" of this manual for all applications requiring a 24V connection. Connect wiring with all power sources off.

- 24 VDC (nominal) @ 0.5 A max
- 5 VDC (nominal) @ 0.15 A max



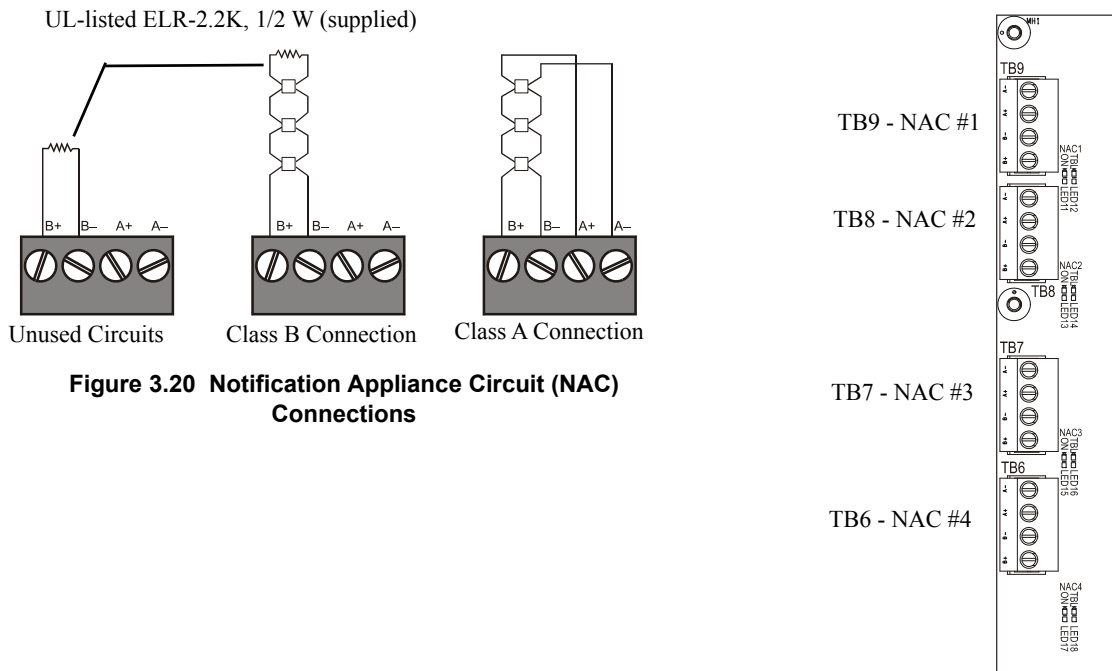


AMPS24\_TB2access.wmf

**Figure 3.19** Connecting to the Accessories Output TB2 on CPS-24/E

### 3.8 NAC Connections and Releasing Circuits

The control panel provides four NAC terminals as shown in Figure 3.21. Each can be configured as Class B or Class A as shown in Figure 3.20. Each circuit can provide 1.5 A of current, but the total current drawn from the main power supply cannot exceed 7.4 A in alarm condition (refer to Table A.2). Additionally, TB10, TB2, and all 4 NACs share a maximum of 3.0 A in standby and 6.0 A in alarm; see Appendix A. NAC circuits are supervised and power-limited. Use UL-listed 24 VDC notification appliances only (refer to the *Device Compatibility Document*).



**Figure 3.20** Notification Appliance Circuit (NAC) Connections

**Figure 3.21** NAC Terminals and NAC LEDs



**NOTE:** Any NAC can be programmed as a releasing circuit, and the releasing circuit must be supervised; see Figure 4.8–Figure 4.10. For more information, refer to Section 4 “Applications” in this manual and the NFS2-640/E Programming Manual. Refer to the Device Compatibility Document for UL-listed compatible releasing devices. Sample connections for NAC terminals are shown in Figure 3.20. Follow sequence of steps in Section 3.2 “Installation Checklist”, Table 3.1; this is part of Step 6.

### 3.8.1 Stat-X Devices

Figure 3.22 shows typical wiring for STAT-X devices using the Ematch Protection Device (P/N 3005014). When using Stat-X devices, note the following:

- Each Stat-X device requires an Ematch Protection Device to protect against high-voltage transient signals, such as lightning, that may cause the device to accidentally release.
- Multiple Stat-X devices can be connected in series (as shown).
- No more than ten (10) Stat-X devices can be connected on a single releasing circuit.
- A REL-2.2K can be installed on a single Stat-X device for short circuit detection. For multiple Stat-X devices installed in series, the REL-2.2K is installed on the last device on the releasing circuit (as shown). A REL-2.2K is required for ULC applications.
- Stat-X devices are not to be used with the FCM-1 or FCM-1-REL.

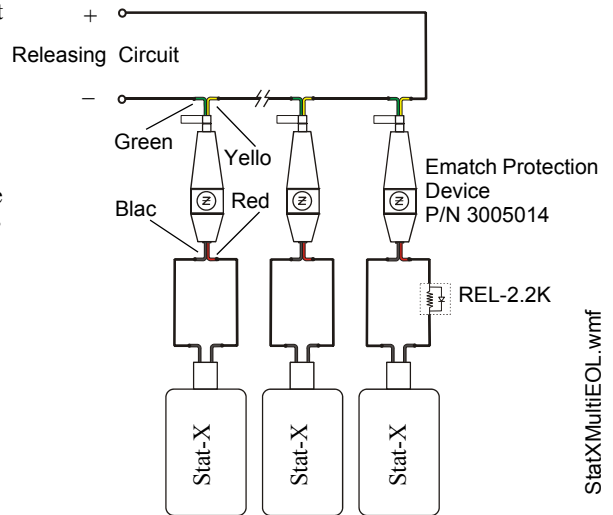


Figure 3.22 Wiring Diagram for Stat-X Devices

### 3.8.2 FSA-8000 Wiring:

Figure 4 shows the wiring for the FSA-8000 detector to the fire alarm control panel.

For installation information for the FSA-8000 detector, refer to the FSA-8000 FAAST Installation and Maintenance Instruction document, part number I56-3903.

#### Installation Considerations:

The following installation factors should be taken into consideration when installing the FSA-8000 FAAST detector:

- Detectors per Loop: up to 75 total
- Modules per Loop: up to 45 total
- Power Supply: FACP AUX or use a power supply UL listed for fire protective signaling use with regulated outputs.

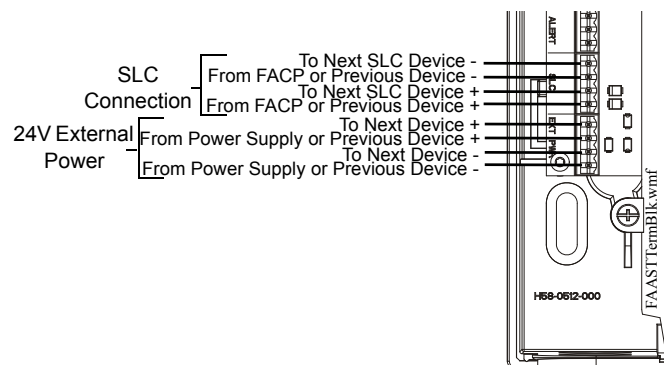


Figure 4 FSA-8000 Connection to the FACP

#### Programming Options:

The following programming options should be set when programming the NFS-320, NFS-320SYS, NFS2-640 and NFS2-3030 with the FSA-8000:

- Loop Protocol: CLIP for detectors
- Type ID: Acclimate
- FlashScan Type ID: None

### 3.9 Output Relay Connections

The panel provides a set of Form-C relays. These are rated for 2.0 A at 30 VDC (resistive):

- Alarm - TB4
- Trouble - TB4
- Supervisory - TB5
- Security - TB5

These are power-limited only if connected to a power-limited source.

Using VeriFire Tools, the Supervisory and Security contacts can also be configured as Alarm contacts. Follow instructions in the VeriFire Tools online help.

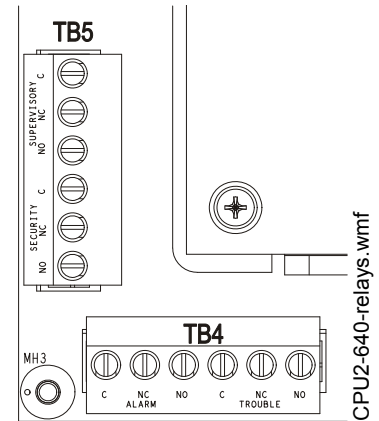


Figure 3.1 Form-C Relay Connections

### 3.10 Backup-Alarm Switches



**WARNING:** DO NOT ENABLE THE BACKUP OPTION SWITCH FOR ANY OF THE FOUR NOTIFICATION APPLIANCE CIRCUITS (NACS) IF THEY ARE USED FOR RELEASING FUNCTIONS!

Backup alarm switches are provided that enable NACs and the alarm relay to activate during a backup alarm condition. If the main board's microcontroller fails and an alarm is reported by any detector or a monitor module that has backup reporting enabled, the NAC will turn on if the corresponding switch was enabled. The alarm will activate during microcontroller failure regardless of the settings of switches SW1–SW4.

- SW1 - NAC#1
- SW2 - NAC#2
- SW3 - NAC#3
- SW4 - NAC#4

So, for example, if SW1 and SW4 were enabled at the time of an alarm during microcontroller failure, NAC#1 and NAC#4 would activate. Follow sequence of steps in Section 3.2 “Installation Checklist”, Table 3.1; this is Step 7.

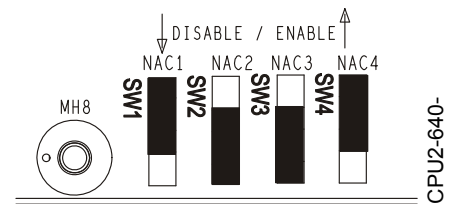
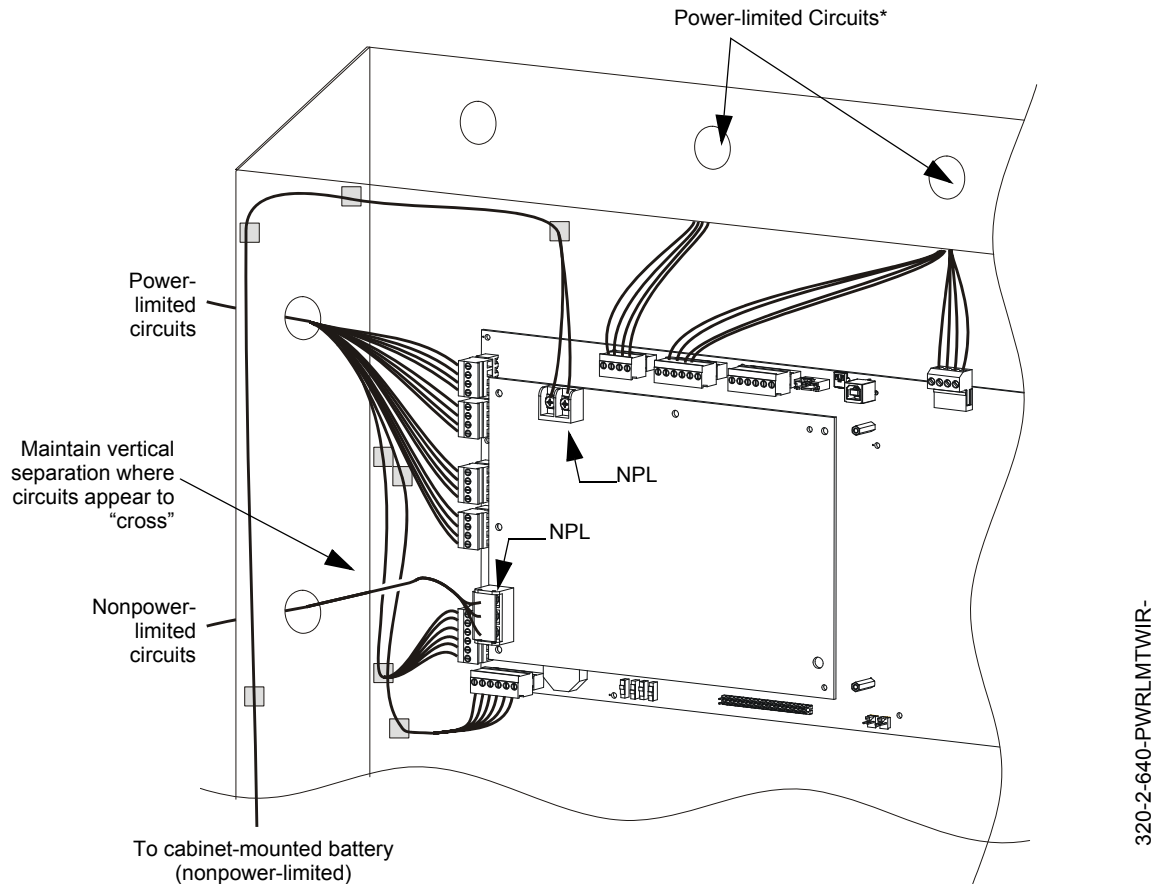


Figure 3.2 Backup Alarm Switches

### 3.11 UL Power-limited Wiring Requirements

Power-limited and nonpower-limited circuit wiring must remain separated in the cabinet. All power-limited circuit wiring must remain at least 0.25 inches (6.35 mm) from any nonpower-limited circuit wiring. All power-limited and nonpower-limited circuit wiring must enter and exit the cabinet through different knockout and or conduits. To maintain separation, group non-power limited modules together, i.e., group modules on the same side of the enclosure or in separate rows.

Figure 3.3 shows one configuration that meets these UL requirements. The first two rows of modules are configured with at least a 0.25 inch (6.35 mm) separation between power-limited and nonpower-limited wiring; AC and battery wiring is routed away from power-limited wiring.



**Figure 3.3 Typical Wiring for UL Power-limited Wiring Requirements  
(Shown with relays as connected to power-limited modules)**



**NOTE:** AC and battery wiring are not power-limited. Maintain at least 0.25 inches (6.35mm) between power-limited and non power-limited circuit wiring. Install tie wraps and adhesive squares to secure the wiring. Use a power-limited source for relay output on terminals TB8-TB11. Figure 2.2, “CPU2-640/CPU2-640E and Power-Supply: Wiring Connections” on page 13



**NOTE:** Drawing is not to scale. Proportions and angles are exaggerated to show wire-placement more clearly.



**NOTE:** If additional knockouts are added to the backbox, proper separation of power-limited and non power-limited wiring should be maintained.

#### 3.11.1 Labeling Modules and Circuits

At the time of installation, each nonpower-limited circuit connected to ACM-8R, and LDM-R32 modules must be identified in the space provided on the cabinet door label when connected to a non-power-limited source of power.

The label lists all compatible power-limited modules and circuits; also see Figure 2.2 on page 13. The LDM-R32 is power-limited only when connected to power-limited sources. When connected to a non-power-limited source, the power-limited marking must be removed.

## 3.12 Installing EIA-485 Devices

Figure 3.4 provides a closer view of the EIA-485 connections provided on TB11. Because specific connections can vary by the type of device being connected, refer to the product installation manual for details.

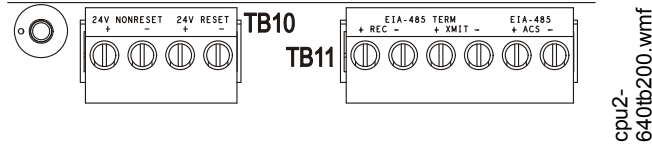


Figure 3.4 EIA-485 Connections

## 3.13 Installing Remote Printers and/or CRT

### 3.13.1 Custom Cable Fabrication

A custom cable needs to be fabricated to connect the PRN Printer, Keltron Printer or the CRT-2 Monitor to the system. Length of the cable will vary with each installation, but should not exceed a maximum length of 50 feet (15.24 m). Printer must be installed in the same room as the panel, within 20 feet (6.10 meters) and the cable must be installed in conduit. Construct cable as follows:

1. Using overall foil/braided-shield twisted-pair cable, properly connect one end to the DB-25 or DB-9 Connector using the wiring specifications shown in the table below.
2. Tighten clamp on connector to secure cable.

DB-9 Connector	DB-25 Connector	TB12 on Control Panel
Pin 2	Pin 3	TX
Pin 3	Pin 2	RX
Pin 5	Pin 7	REF

### 3.13.2 Installing and Configuring the PRN Series Printer

When connected to the Control Panel via an EIA-232 interface, the PRN prints a copy of all status changes within the control panel and time-stamps the printout with the time of day and date the event occurred. It provides 80 columns of data on standard 9" by 11" tractor-feed paper.



**NOTE:** You can also use the EIA-232 printer interface with UL-listed information technology equipment, such as personal computers, to monitor the control panel for supplementary purposes.

This section contains information on connecting a printer to the control panel and for setting the printer options.

#### Connecting a Remote PRN Series Printer

Remote printers require a 120 VAC, 50/60 Hz primary power source. If required for the fire alarm system configuration (for example, a Proprietary Fire Alarm System), a remote printer requires a secondary power source (battery backup). Because a secondary power source is not provided, use a separate Uninterruptable Power Supply (UPS) that is UL-listed for Fire Protective Signaling. You may use your building emergency power supply, so long as it meets the power continuity requirements of NFPA 72. Refer to NFPA 72 for further details.

Connect the remote printer to the Control Panel as follows:

1. Connect the three (3) open leads of the custom cable to the TB12 terminal block on the control panel as shown in Figure 3.5.
2. Plug the DB-25 or DB-9 connector end of the custom cable into the EIA-232 port of the remote printer. Tighten securely.

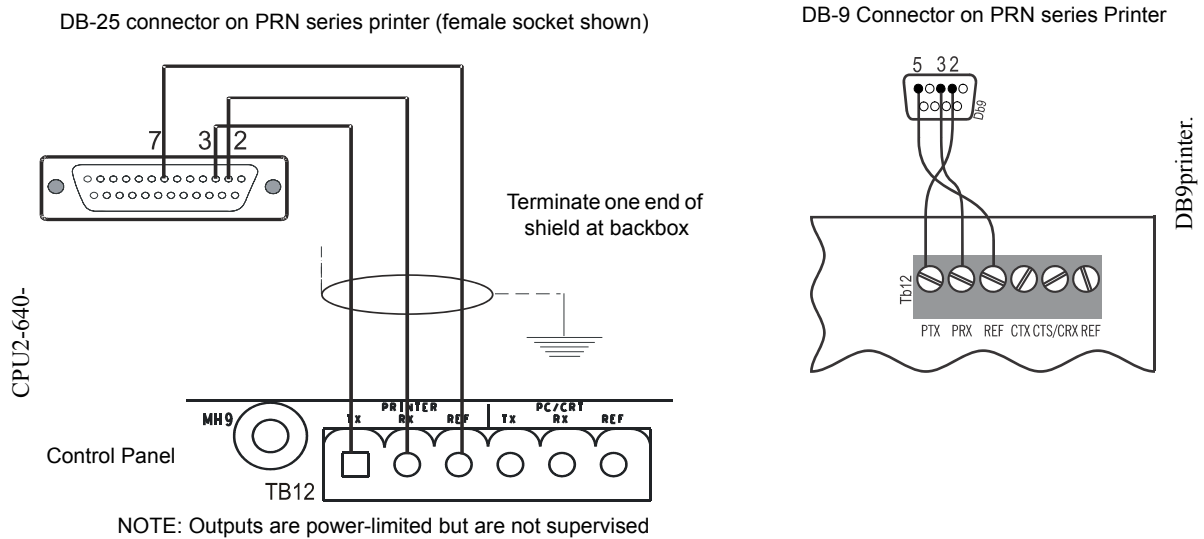


Figure 3.5 Remote Printer Connections

### Setting Printer Options

Refer to the documentation supplied with the PRN series printer for instructions on using the printer menu controls. Set the printer options (under the menu area) according to the settings listed in Table 3.6.

Option	Setting	Option	Setting
Font	HS Draft	CPI	10 CPI
LPI	6 LPI	Skip	0.5
ESC Character	ESC	Emulate	Epson FX-850 PRN-6, LQ-2550 PRN-7
Bidirectional Copy	ON	I/O	
CG-TAB	Graphic	Buffer	40K PRN-6, 64K PRN-7
Country	E-US ASCII	Serial	
Auto CR	OFF	Baud	9600, 4800, or 2400
Color Option	Not Installed	Format	7 Bit, Even, 1 Stop
Formlen		Protocol	XON/XOFF
Lines	6LPI=60	Character Set	Standard
Standard	Exec 10.5" PRN-6, 11" PRN-7	Sl.Zero	On
		Auto LF	Off
		PAPER	
		BIN 1	12/72"
		BIN 2	12/72"
		SINGLE	12/72"
		PUSH TRA	12/72"
		PULL TRA	12/72"
		PAP ROLL	12/72"

Table 3.6 PRN Setup Options

### 3.13.3 Installing and Configuring a Keltron Printer

Connect the remote printer to the Control Panel as follows:

1. Connect the three (3) open leads of the custom cable to the TB12 terminal block on the control panel as shown in Figure 3.6.
2. Connect DC power from TB10 terminal block on the control panel as shown in Figure 3.6.
3. Plug the DB-25 connector end of the custom cable into the EIA-232 port of the Keltron printer. Tighten securely.

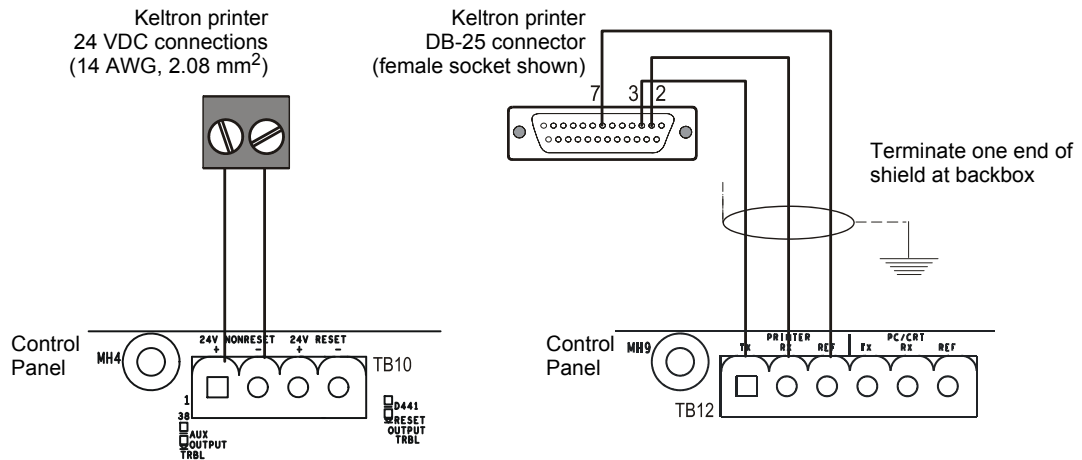


Figure 3.6 Keltron Printer Connections

CPU2-640-

### Setting up the Keltron Printer

Set up a Keltron printer as follows:

1. The printer communicates using the following protocol:
  - Baud Rate: 9600
  - Parity: Even
  - Data bits: 7
2. Set the printer DIP switches SP1 and SP2 according to settings in Table 3.7.

SP1	On	Off
1		X
2		X
3		X
4	X	
5		X
6	X	
7	X	
8		X

SP2	On	Off
1		X
2		X
3		X
4	X	
5		X
6		X
7	X	
8		X

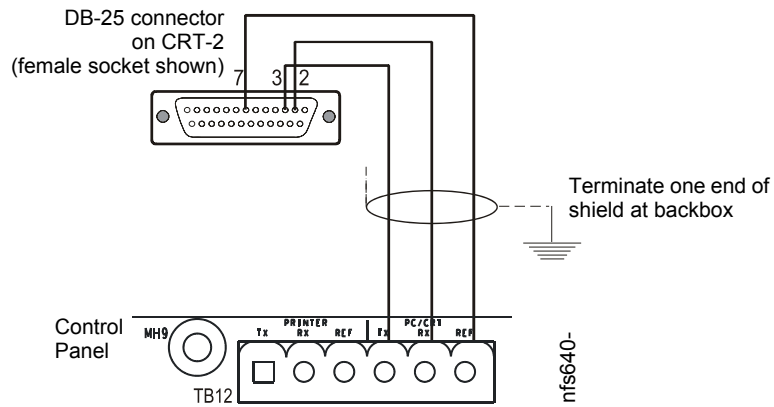
Table 3.7 Keltron DIP Switch Settings

### 3.13.4 Installing and Configuring a CRT-2

A CRT-2 can only be used in a non-networked application when used with the NFS2-640/E. For further details on setting up the CRT-2, refer to the *NFS2-640/E Operations Manual*.

Connect a CRT-2 to the Control Panel as follows:

1. Connect the three (3) open leads of the custom cable to the TB12 terminal block on the control panel as shown in Figure 3.7.
2. Plug the DB-25 connector end of the custom cable into the EIA-232 port of the CRT-2. Tighten securely.
3. Set parameters as discussed in Table 3.7.



**Figure 3.7 Connecting a CRT-2**

### Setting CRT-2 Parameters

The CRT-2 communicates with the control panel through a protocol defined by thirteen groups of parameters. To access a parameter group, press the corresponding function key (F1-F12) as shown in Table 3.8 below. You can then program parameters in each group. Enter the CRT-2 setup menu by pressing and holding the <Ctrl> key while pressing the <Scroll Lock> key. Use arrow keys to move through the selections in each setup group; press the space bar to view the options for each parameter. When finished programming all setup groups, press the <Pause> key. To save all changes, press <Y>.

Table 3.8 shows the standard settings for using the CRT-2 with the NFS2-640/E; for one instance where these settings may change slightly see Section 3.13.5 “Connecting Multiple Printers, CRTs, or CRT/PRN Combination”. The basic settings for using the CRT-2 with NFS2-640/E are:

- Baud Rate 9600
- Data format 8 1 N
- Protocol xon/off.



**NOTE:** This section covers installation only; for information on how the CRT-2 functions as part of the fire alarm system, see the *NFS2-640/E Operations Manual*.



**NOTE:** The CRT cannot be connected at the same time as the network



Function Key	CRT-2 Parameters		
F1: Quick ("Read Status" key)	Emulation=CRT-2 Comm Mode=Full Duplex Enhanced=On	EIA Baud Rate=9600 Aux Baud Rate=9600 Language=U.S.	EIA Data Format=8/1/N Aux Data Format=8/1/N Host/Printer=EIA/Aux
F2: Genrl ("Alter Status" key)	Emulation=CRT-2 Auto Font Load=On Monitor Mode=Off Host/Printer=EIA/Aux	Enhanced=On Auto Page=Off Bell Volume=09	Auto Wrap=Off Auto Scroll=On Warning Bell=On
F3: Displ ("Prog" key)	Page Length=24 Display Cursor=On Columns=80 Scroll=Jump	Screen Length=26 Lines Cursor=Blink Line Width Change Clear=Off Refresh Rate=60 Hz	Screen Video=Normal Auto Adjust Cursor=On Speed=Normal Overscan Borders=Off
F4: Kybd ("Spl Funct" key)	Language=U.S. Keyclick=Off Key Lock=Caps	Char Set Mode=ASCII Key Repeat=Off Keyboard Present=Yes	Key Mode=ASCII Margin Bell=Off
F5: Keys ("Prior" key)	Enter Key=<CR> Alt Key=Meta Pound Key=U.S.	Return Key=<CR> Disconnect=Pause	Backspace=<BS>/<DEL> Desk Acc=Disabled
F6: Ports ("Next" key)	EIA Baud Rate=9600 Aux Baud Rate=9600 EIA Xmt=Xon-Xoff Aux Xmt=Xon-Xoff EIA Break=Off Aux Break=Off	EIA Data Format=8/1/N Aux Data Format=8/1/N EIA Recv=Xon-Xoff(XPC) Aux Recv=Xon-Xoff(XPC) EIA Modem Control=Off Aux Modem Control=Off	EIA Parity Check=On Aux Parity Check=On EIA Xmt Pace=Baud Aux Xmt Pace=Baud EIA Disconnect=2 sec Aux Disconnect=2 sec
F7: Host ("Auto Step" key)	Comm Mode=Full Duplex Recv <DEL>=Ignore Send Block Term=<CR>	Local=Off Send ACK=On Null Suppress=On	Recv <CR>=<CR> Send Line Term=<CR><LF>
F8: Print ("Activ Signal" key)	Prnt Line Term=<CR><LF>	Prnt Block Term=<CR>	Secondary Recv=Off
F9: Emul	Attribute=Page WPRT Intensity=Dim WPRT Blink=Off Status Line=Off	Bright Video=Off WPRT Reverse=Off Display NV Labels=Off Fkey Speed=Normal	Page Edit=Off WPRT Underline=Off Save Labels=On
F10	Setup Group F10 does not affect communications with the control panel.		
F11	Setup Group F11 does not affect communications with the control panel.		
F12: Prog ("Ack Step" key)	Program the function keys as follows: F1 ~A F2 ~B F3 ~C F4 ~D F5 ~E F6 ~F F7 ~G F8 ~H F9 ~I F10 ~J F11 ~K F12 ~L F13 ~M F14 ~N F15 ~O F16 ~P Shift F13 ~Q		

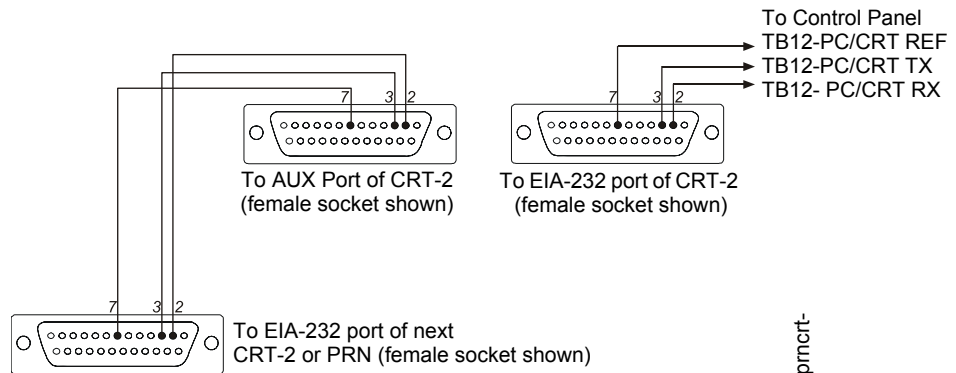
**Table 3.8 Standard CRT-2 Settings for Use with NFS2-640/E**

### 3.13.5 Connecting Multiple Printers, CRTs, or CRT/PRN Combination

Connecting multiple devices requires changing the CRT-2 setup using the F1(Quick) menu:

- Set Host/Printer=EIA/AUX.
- Set EIA Data Format=8/1/N.
- If the AUX device is a printer, set the Printer and AUX Data Format=7/1/E.
- If the AUX device is a second CRT-2, set the AUX Data Format=8/1/N.

Connect multiple devices as shown in Figure 3.8.



Note: For wire requirements, see Table B.1 in Appendix B.1 "Electrical Specifications".

**Figure 3.8 Connecting Multiple Devices on the EIA-232 Circuit**

### 3.14 Wiring a Signaling Line Circuit (SLC)

#### ■ Overview

Communication between the control panel and intelligent and addressable initiating, monitor, and control devices takes place through a Signaling Line Circuit (SLC). You can wire an SLC to meet the requirements of NFPA Style 4, Style 6, or Style 7 circuits. This manual provides requirements and performance details specific to this control panel; for installation information and general information, refer to the *SLC Wiring Manual*.

#### ■ Wiring

Maximum wiring distance of an SLC using 12 AWG (3.31 mm<sup>2</sup>) wire is 12,500 feet (3810 meters) total twisted-pair for Style 4, Style 6 and Style 7 circuits.

#### ■ Capacity

The NFS2-640/E provides one (1) SLC, with a total capacity of 318 intelligent/addressable devices:

- 01-159 intelligent detectors
- 01-159 monitor and control modules

An optional expander board provides one (1) additional SLC, with the same capacity.

Units employing multiple detector operation shall include a minimum of two detectors in each protected space and reduce the detector installation spacing to 0.7 times the linear spacing in accordance with National Fire Alarm Code, NFPA. For spacing requirements refer to the detector's installation instruction.



**NOTE:** To meet the ten-second response time required by UL 864, 9th edition, when SLC loops are configured to run in CLIP mode, all input modules must be set to address 19 or lower on both loop one and 2. There are no limits to detectors or output modules.

#### ■ Installation

This control panel supports one or two SLC loops; a second SLC loop is obtained by installing an LEM-320 module. SLC loop #1 connects to TB13 on the control panel; SLC loop #2 connects to TB1 on the LEM-320. For details on designing, installing and configuring SLC loops, see the *SLC Wiring Manual*.

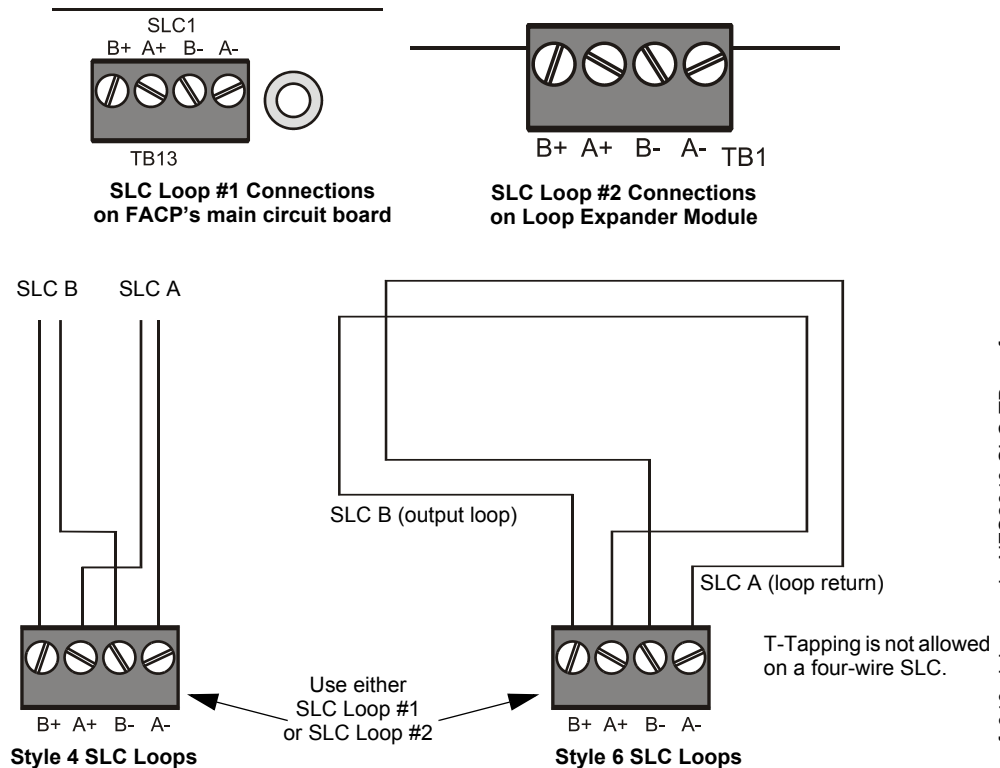


Figure 3.9 SLC Loop Connections and Wiring

### 3.15 Connecting a PC for Off-Line Programming

A PC can be hooked up to the control panel to allow the VeriFire Tools programming utility to upload and download the operating program. Refer to the insert in the VeriFire Tools CD insert and to the program's on-line help function for instructions. There are two options for connection:

1. For PCs with USB Ports, connect the PC to USB B via a standard USB B cable.
2. For PCs without USB Ports, connect the PC's serial port to the Control Panel Network/Service Connection (J1, NUP).



---

**NOTE:** Download operations that change the basic program of the control panel must be performed by responsible service personnel in attendance at the control panel. After downloading a program, test the control panel in accordance with NFPA 72.

---

# Section 4: Applications

## 4.1 Overview

Chapter	Covers the following topics
Section 4.3 "NFPA 72 Central or Remote Station Fire Alarm System (Protected Premises Unit)"	How to install UDACT/UDACT-2 with the control panel for use as a NFPA Central or Remote Station Fire Alarm System (Protected Premises Unit)
Section 4.5 "NFPA 72 Proprietary Fire Alarm Systems"	How to set up a Protected Premises Unit to communicate with a listed compatible Protected Premises Receiving Unit.
Section 4.6 "Fire/Security Applications"	How to use the control panel as a combination Fire/Security system, including the following: <ul style="list-style-type: none"> <li>• Installing a Security Tamper Switch into the cabinet</li> <li>• Circuit Wiring</li> </ul>
Section 4.7 "Releasing Applications"	How to install the following releasing applications: <ul style="list-style-type: none"> <li>• Releasing Device to the Control Panel (NAC integral circuits)</li> <li>• Releasing Device to the FCM-1 Module</li> <li>• Releasing Device to the FCM-1-REL Module</li> <li>• NBG-12LRA Agent Release-Abort Station</li> </ul>

Table 4.1

### Municipal Box (Auxiliary)

Municipal Box applications require a TM-4 Transmitter module. Refer to the *TM-4 Transmitter Module* installation document for installation details.

## 4.2 Devices Requiring External Power Supervision

With software version 12.0 or higher, certain type codes have external power supervision (FlashScan only) built into the software. An external power-supervision relay is required (see Figure 4.1) unless one of the following typecodes is selected for the device:

- Control
- Strobe
- Horn
- (Blank)
- Release Ckt
- Rel Ckt Ulc
- Nonreset Ctl
- Alarms Pend
- Gen Alarm
- Gen Supervis
- Gen Trouble
- Gen Pend
- Trouble Pend

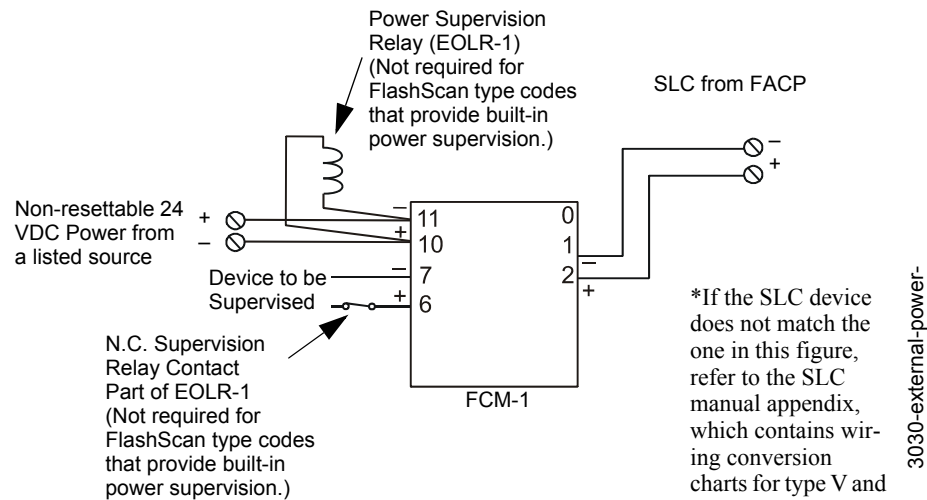


Figure 4.1 Enabling External Power Supervision Using Relays

## 4.3 NFPA 72 Central or Remote Station Fire Alarm System (Protected Premises Unit)

Figure 4.2 shows typical wiring diagram for a NFPA 72 Central Station Fire Alarm System (Protected Premises Unit) or a Remote Station Fire Alarm System (Protected Premises Unit) using the Universal Digital Alarm Communicator/Transmitter (UDACT or UDACT-2) and control panel. This provides typical wiring only; connect and program the UDACT or UDACT-2 according to the directions given in the *UDACT Instruction Manual* or *UDACT-2 Instruction Manual*.



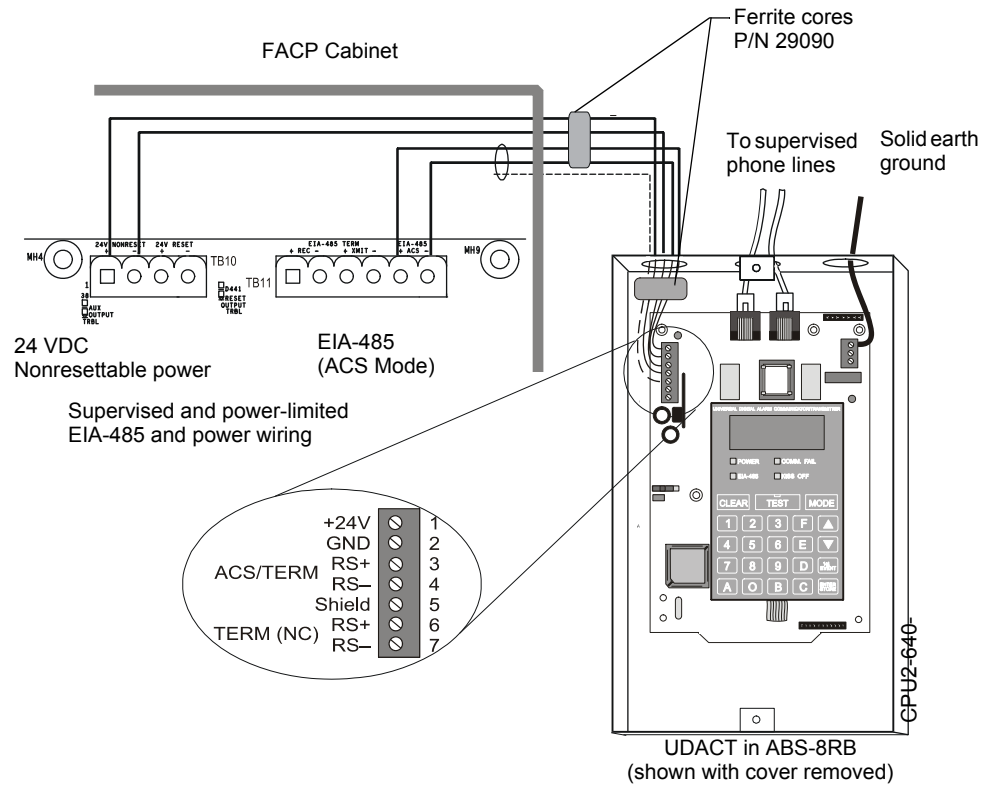
**NOTE:** An NFPA 72 Central Station or Remote Station requires 24 hours of standby power and 5 minutes in alarm.



**NOTE:** This application can also be done with the TM-4 Transmitter; refer to the *TM-4 Transmitter Module* installation document for more details.



**NOTE:** For additional setup information for the UDACT-2, refer to the *UDACT-2 Instruction Manual*.



**Figure 4.2 Typical Wiring Diagram for a Central Station Fire Alarm System**



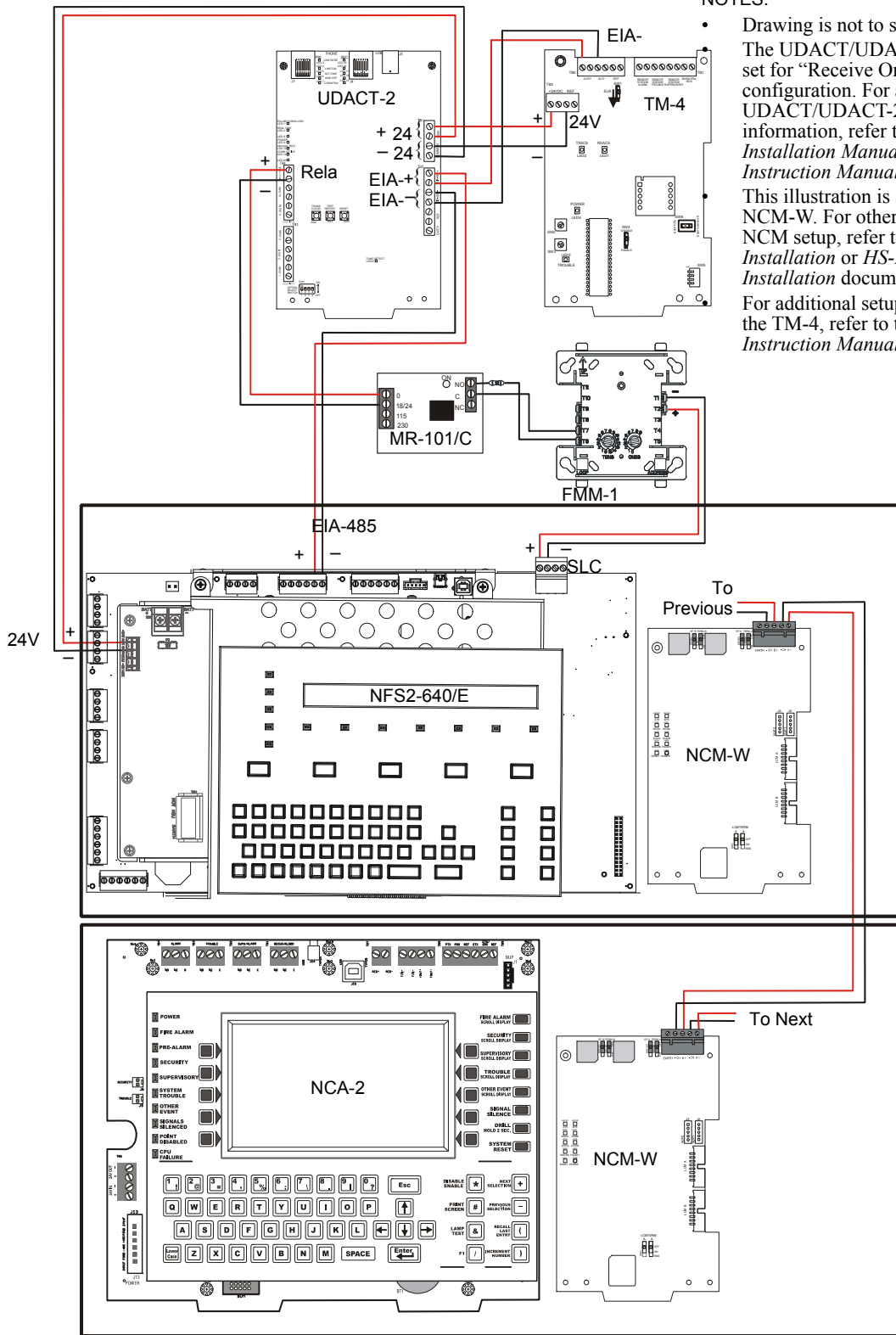
**NOTE:** Install a UL-listed 120 ohm End-of-Line resistor (P/N 71244) UDACT TB1 terminals 3 and 4 if this is the last or only device on EIA-485 line.

### 4.4 Central Station Fire Alarm System Canadian Requirements

For Canadian applications requiring a second dial-out option, refer to the following illustration for UDACT/UDACT-2 and TM-4 setup:

**NOTES:**

- Drawing is not to scale.
- The UDACT/UDACT-2 should be set for "Receive Only" for this configuration. For additional UDACT/UDACT-2 setup information, refer to the *UDACT Installation Manual* or *UDACT-2 Instruction Manual*.
- This illustration is show with the NCM-W. For other NCM or HS-NCM setup, refer to the *NCM Installation* or *HS-NCM Installation* documents.
- For additional setup information on the TM-4, refer to the *TM-4 Instruction Manual*.



**Figure 4.3 Central Station Canadian Requirements for Second Dial-Out Connection**

## 4.5 NFPA 72 Proprietary Fire Alarm Systems

When connected and configured as a protected premises unit with UDACT or UDACT-2, the NFS2-640/E will automatically transmit General Alarm, General Trouble, and General Supervisory signals to a listed compatible Protected Premises Receiving Unit. See the *UDACT Manual* or *UDACT-2 Manual* for compatible receiving units. A simplified drawing of connections between the receiving unit and the NFS2-640/E protected premises unit is shown in Figure 4.4.

Connect the receiving unit to the protected premises unit as shown in Section 4.3 “NFPA 72 Central or Remote Station Fire Alarm System (Protected Premises Unit)”.

For information on installing and programming the Receiving unit, refer to the documentation for that control panel.

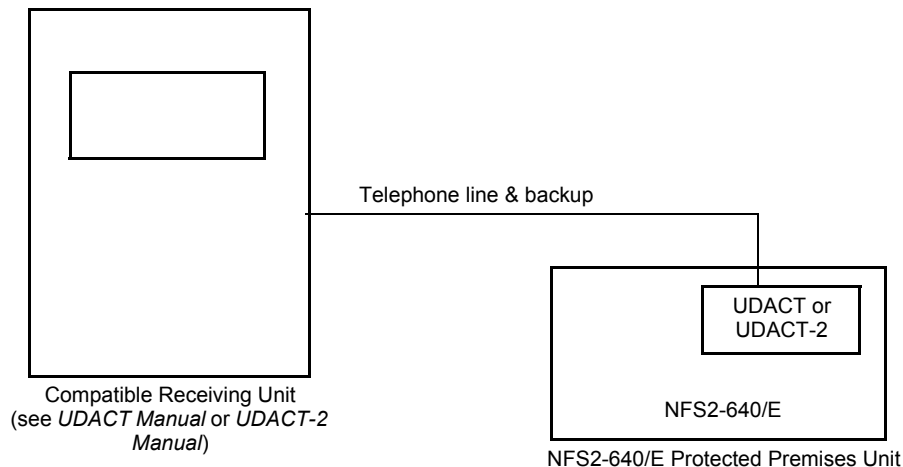


Figure 4.4 Typical Proprietary Fire Alarm Systems Wiring Connections

## 4.6 Fire/Security Applications



**NOTE:** NFS2-640/E is not approved for use in security applications in Canada.

### 4.6.1 General Operation

The control panel can be used as a combination Fire/Security system when installed and operated according to the instructions in this section.

For security applications, program one or more monitor modules (listed for security applications) with the SECURITY Type Code, and wire as shown in Figure 4.6. Activating this type of module lights the SECURITY LED, and displays a security alarm condition on the control panel LCD display. The panel sounder will sound until the Security alarm is acknowledged. You can also program additional sounders or output devices to activate with the security alarm initiating device. The SECURITY Type Code is designed to indicate an alarm as follows: (a) on an open or short circuit; or (b) on a  $\pm 50\%$  change in resistance value from the End-of-Line resistor value.

A tamper switch installed in the cabinet door will indicate a door tamper condition whenever the door is open. If the control panel indicates a Security alarm, you can acknowledge, silence, and reset the condition from the control panel.

When the system resets, a 30-second exit timer starts. During this time the tamper switch and all Security alarms are ignored. There is no entrance delay timer.

For bypass of security zones, use the DISABLE routine (covered in the *Status Change* section of the *NFS2-640/E Operations Manual*) for Security type devices.



**WARNING:**

Damage can result from incorrect wiring connections.

### 4.6.2 Installing a Security Tamper Switch

To wire the cabinet with a Security Tamper Switch kit model STS-1, refer to Figure 4.5:

1. Install the STS-1 Tamper Switch onto the side of the backbox opposite the door hinge, pushing the switch through the opening until it snaps into place.
2. Install the magnet on the same side of the cabinet door as the lock. Push the magnet through the opening in the door until it snaps into place.
3. Connect the STS-1 connector to J5 (Security Tamper) on the Control Panel. (As shown in Figure 4.5, J5 is located on the circuit board, underneath the edge of KDM-R2.)

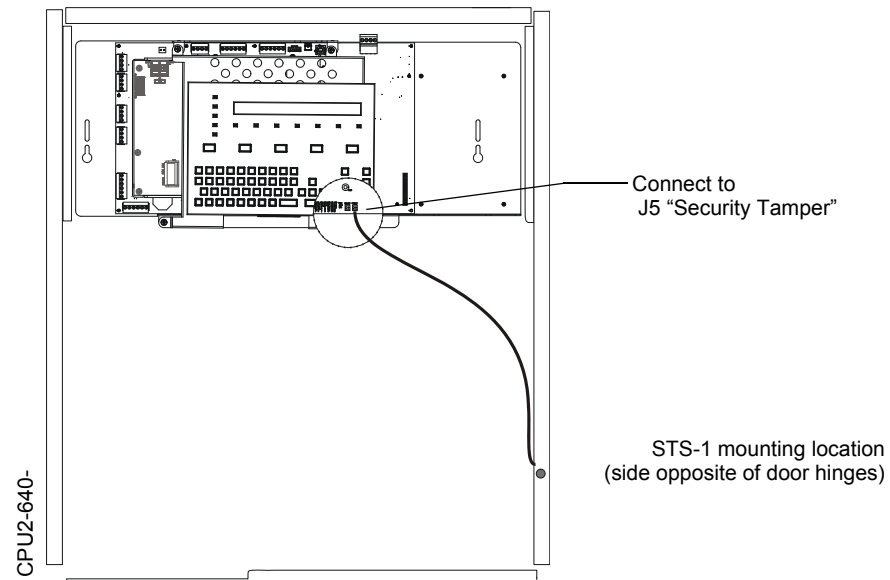


Figure 4.5 Installing the STS-1 Security Tamper Switch

### 4.6.3 Receiving Unit

For applications requiring transmission of security alarm information to a central receiving unit, the control panel may be connected via the UDACT or UDACT-2 to a compatible receiving unit (see the *UDACT Manual* or *UDACT-2 Manual*). For information on configuring the Receiving unit for Combination Fire/Security applications, refer to the documentation for that control panel.

### 4.6.4 Programming

The control panel can communicate with any number of security devices. To do so, program the points as follows:

1. Select the address of the module(s) to be used for security.
2. Select the Type Code SECURITY.



**NOTE:** For detailed instruction on programming Type Codes, refer to the *NFS2-640/E Programming Manual*.

### 4.6.5 Wiring for Proprietary Security Alarm Applications

Table 4.6 shows typical wiring for proprietary security alarm applications with FMM-1 modules. Note the following:

- The module is programmed with software SECURITY Type Code.
- For use with UL listed systems only; application not for ULC security usage.
- NAC devices used for security cannot be shared with fire NAC devices.
- Refer to the *Device Compatibility Document* for compatible NAC devices.
- All monitor modules used for security application must be installed in the NFS2-640/E cabinet with STS-1 Security Tamper Switch.

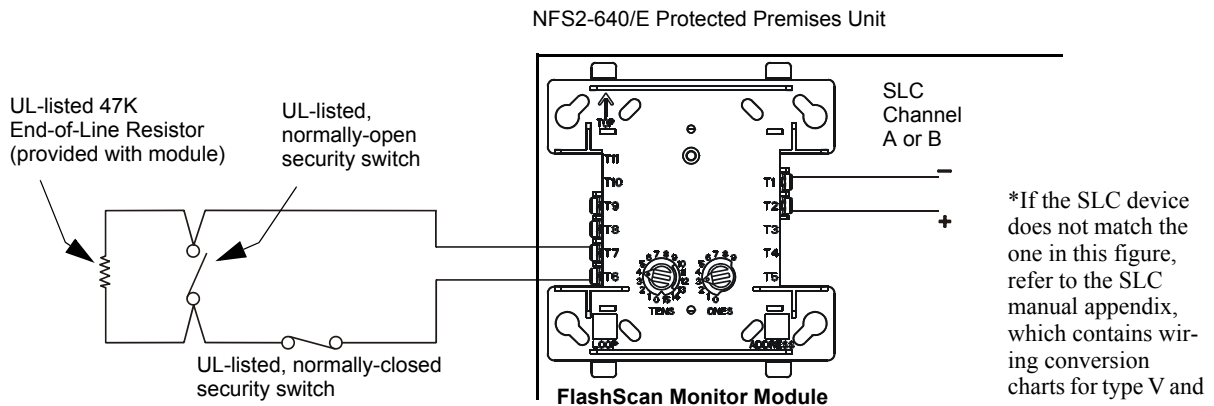


Figure 4.6 Wiring Diagram for Proprietary Security Alarm Applications



## 4.7 Releasing Applications



**WARNING:**

WHEN USED FOR CO<sub>2</sub> RELEASING APPLICATIONS, OBSERVE PROPER PRECAUTIONS AS STATED IN NFPA 12. DO NOT ENTER THE PROTECTED SPACE UNLESS PHYSICAL LOCKOUT AND OTHER SAFETY PROCEDURES ARE FULLY COMPLETED. DO NOT USE SOFTWARE DISABLE FUNCTIONS IN THE PANEL AS LOCKOUT.



**WARNING:**

DO NOT ENABLE THE BACKUP OPTION SWITCH FOR ANY OF THE FOUR NOTIFICATION APPLIANCE CIRCUITS (NACS) IF THEY ARE USED FOR RELEASING FUNCTIONS!

### 4.7.1 Overview

This control panel can be used for agent release or preaction/deluge control applications. In a properly configured system with compatible, listed actuating and initiating devices, this control panel complies with the following NFPA standards for installation in accordance with the acceptable standard:

Standard	Covers
NFPA 12	CO <sub>2</sub> Extinguishing Systems
NFPA 12A	Halon 1301 Extinguishing Systems
NFPA 13	Sprinkler Systems
NFPA 15	Water Spray Systems
NFPA 16	Foam-Water Deluge and Foam-water Spray Systems
NFPA 17	Dry Chemical Extinguishing Systems
NFPA 17A	Wet Chemical Extinguishing Systems
NFPA 2001	Clean Agent Fire Extinguishing Systems

**Table 4.2 NFPA Standards for Releasing Applications**

To locate your specific releasing applications, including type codes and wiring diagrams, see the checklist in Table 4.3:

Refer to
Section 4.7.2 "Programming"
Section 4.7.3 "Connecting a Releasing Device to the Control Panel".
Section 4.7.4 "Connecting a Releasing Device to the FCM-1 Module".
Section 4.7.6 "Connecting an NBS-12LRA Agent Release-Abort Station".

**Table 4.3 Locating Specific Releasing Application Details in This Manual**

### 4.7.2 Programming

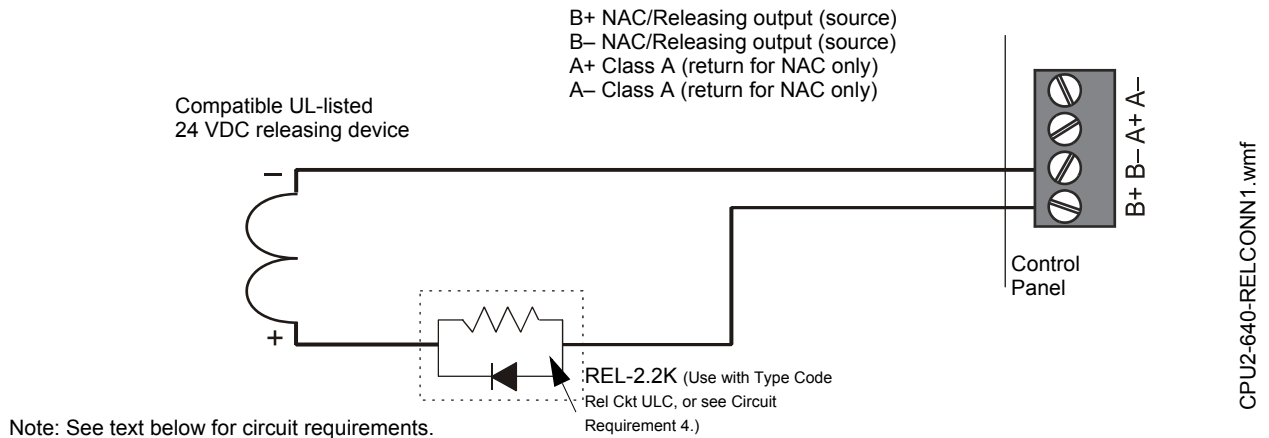
The control panel supports up to ten releasing software zones. You can map these zones to activate Control Panel releasing outputs and FCM-1 modules. Program the FCM-1 module for the appropriate type code according to the chart below:

<p>Type Code: RELEASE CKT</p> <ul style="list-style-type: none"> <li>• For use in UL applications.</li> <li>• Do not use REL device at the solenoid.</li> <li>• Cannot use power-limited wiring.</li> <li>• Supervised for open circuit only.</li> <li>• Supervised for power loss with power-supervision relay.</li> </ul>	<p>Type Code: REL CKT ULC</p> <ul style="list-style-type: none"> <li>• For use in UL or ULC applications.</li> <li>• Requires REL device at solenoid.</li> <li>• Power-limited wiring.</li> <li>• Supervised for open circuit and shorts.</li> <li>• Supervised for power loss with power-supervision relay.</li> </ul>
---	---

For more information, refer to the *NFS2-640/E Programming Manual*.

### 4.7.3 Connecting a Releasing Device to the Control Panel

Use TB6 (NAC#4), TB7 (NAC#3), TB8 (NAC#2), or TB9 (NAC#1) on the control panel for NAC/Releasing Circuits. The releasing circuit must be supervised and use listed, compatible releasing devices; see Figure 4.8–Figure 4.10 (page 50).



**Figure 4.7 Typical Class B Connection of a Releasing Device to Control Panel**



**WARNING:**

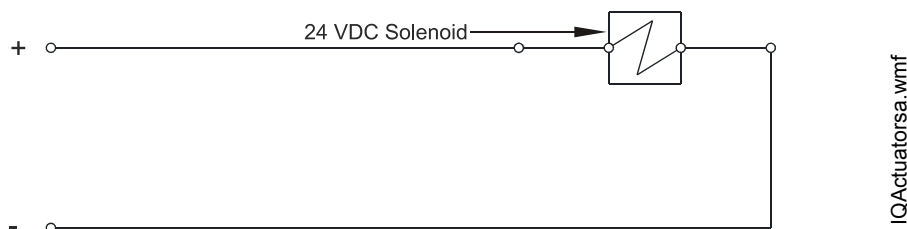
**DO NOT ENABLE THE BACKUP OPTION SWITCH FOR ANY OF THE FOUR NOTIFICATION APPLIANCE CIRCUITS (NACS) IF THEY ARE USED FOR RELEASING FUNCTIONS!**

**Circuit Requirements.** When connecting a releasing device, note the following:

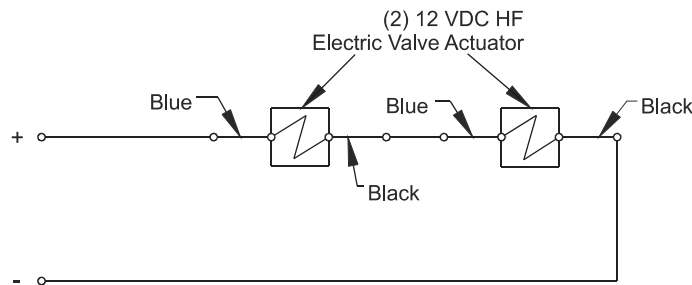
1. The control panel provides four NAC/Releasing Circuits (Class A or Class B). Each circuit can provide 1.5 A. Total current drawn from the power supply cannot exceed 7.4 A in an alarm condition (refer to Table A.2, “System Draw Current Calculations,” on page 56). Use compatible UL-listed 24 VDC appliances only. For more information on compatible appliances, refer to the *Device Compatibility Document*.
2. Refer to the Releasing Applications appendix in the *NFS2-640/E Programming Manual* for configuration details (such as setting the Soak Timer).
3. For applications using power-limited circuits:
  - a) Use an in-line supervisory device (P/N REL-2.2K) with control panel releasing circuits. Connect the End-of-Line device as shown in Figure 4.7.
  - b) Program the releasing circuit for Type Code REL CKT ULC.
  - c) Circuits are supervised against opens and shorts.
4. For applications not requiring power-limited circuits –
  - a) If the application does not require supervising the releasing device against shorts, in-line supervisory devices (P/N REL-2.2K) are not required.
  - b) In non-power-limited applications, program the releasing circuit for Type Code RELEASE CKT.
  - c) Limited energy cable cannot be used to wire a non-power-limited releasing device circuit
  - d) Maintain a 0.25 inch (6.35 mm) spacing between the non-power-limited releasing circuit device wiring and any power-limited circuit wiring.)
5. The releasing circuit must be programmed with a releasing type code listed in the *NFS2-640/E Programming Manual*.



**NOTE:** As per UL 864 9<sup>th</sup> Edition, a supervisory signal must be indicated at the panel whenever a releasing circuit is physically disconnected. Use a monitor module to monitor dry contacts off the switch. See 4.11.

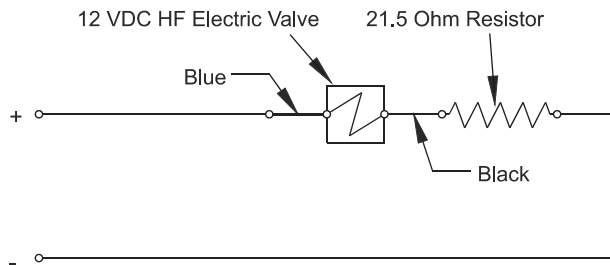


**Figure 4.8 Releasing Circuits (Option 1)**



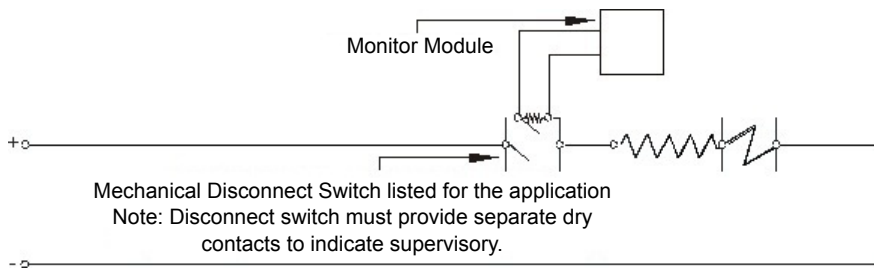
IQActuatorsb.wmf

**Figure 4.9 Releasing Circuits (Option 2)**



IQActuatorsc2010.w

**Figure 4.10 Releasing Circuits (Option 3)**

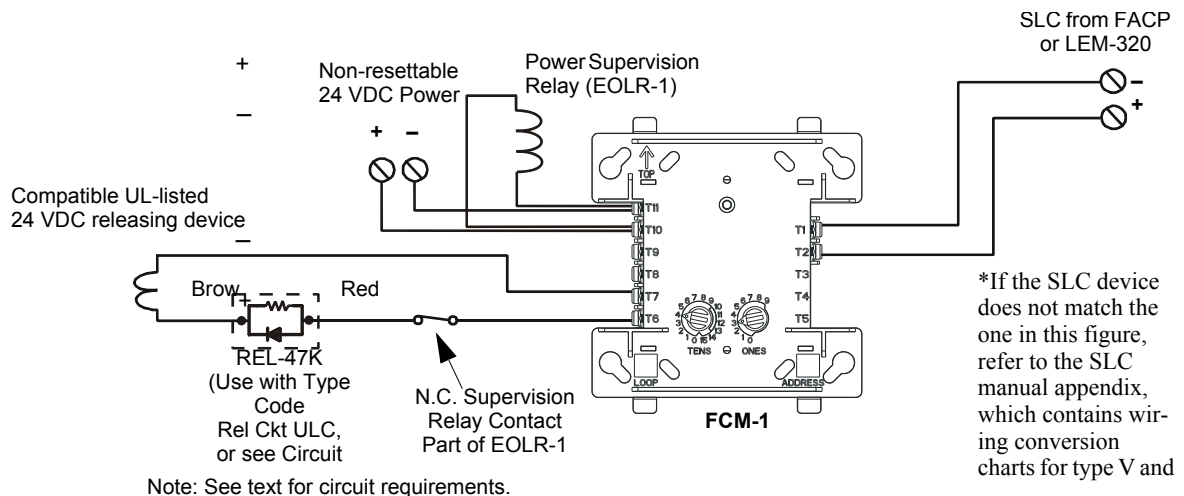


GasDisconnectMod.w

**Figure 4.11 Release Circuits (Mechanical Disconnect Switch)**

### 4.7.4 Connecting a Releasing Device to the FCM-1 Module

The module can control 1 A of current. Make sure to keep total system current within the limits of the power supply. You can power the module from the power supply of the Control Panel or any UL/ULC listed 24 VDC regulated power-limited power supply for Fire Protective Signaling. For more information, refer to the *Device Compatibility Document*.



Relconn-

**Figure 4.12 Typical Connection of a 24 VDC Releasing Device to the FCM-1 Module**

**Circuit Requirements** When connecting a releasing device to the FCM-1 module, note the following:

1. Refer to the Releasing Applications appendix in the *NFS2-640/E Programming Manual* for configuration details (such as setting the Soak Timer).
2. For applications using power-limited circuits:
  - a) Use an in-line supervisory device (P/N REL-47K) with the FCM-1 module. Connect the in-line supervisory device as shown in Figure 4.12.
  - b) Program the releasing circuit for Type Code REL CKT ULC.
  - c) Circuits are supervised against opens and shorts.
3. For applications not requiring power-limited circuits:
  - a) In-line supervisory devices (P/N REL-47K) are not required; however, the releasing device circuit is not supervised against shorts.
  - b) In non-power-limited applications, program the releasing circuit for Type Code RELEASE CKT.
  - c) Limited energy cable cannot be used to wire a non-power-limited releasing device circuit.
  - d) Maintain a 0.25 inch (6.35 mm) spacing between the non-power-limited releasing circuit device wiring and any power-limited circuit wiring.



---

**WARNING:**

THE XP6-C IS NOT LISTED FOR RELEASING APPLICATIONS AND CANNOT BE SUBSTITUTED FOR FCM-1

---



---

**NOTE:** As per UL 864 9th Edition, a supervisory signal must be indicated at the panel whenever a releasing circuit is physically disconnected. Use a monitor module to monitor dry contacts off the switch. See 4.11.

---

## 4.7.5 Connecting Releasing Devices to the FCM-1-REL Control Module

**Typical Connections** Figure 4.13 and Figure 4.13 show typical connections for wiring a releasing device to the FCM-1-REL. Refer to the Device Compatibility Document for compatible releasing devices.

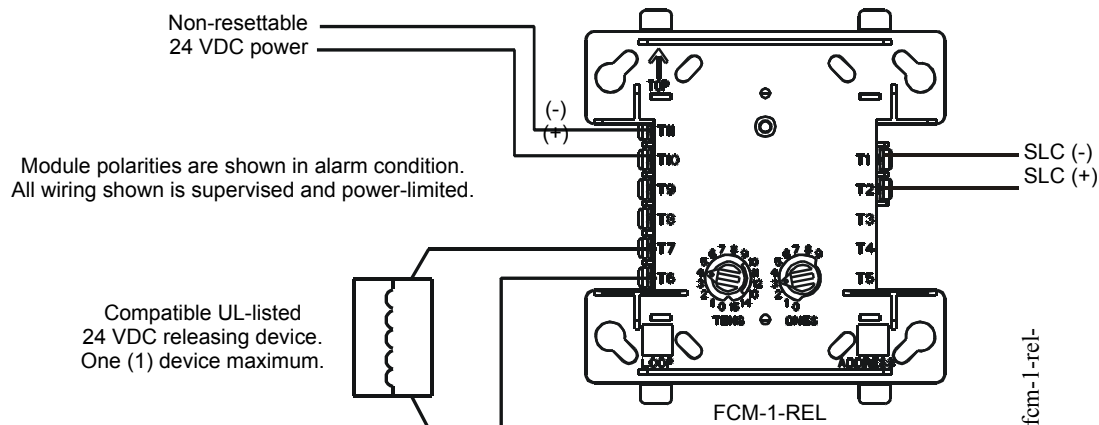


Figure 4.13 NPFA Class B Wiring of the FCM-1-REL

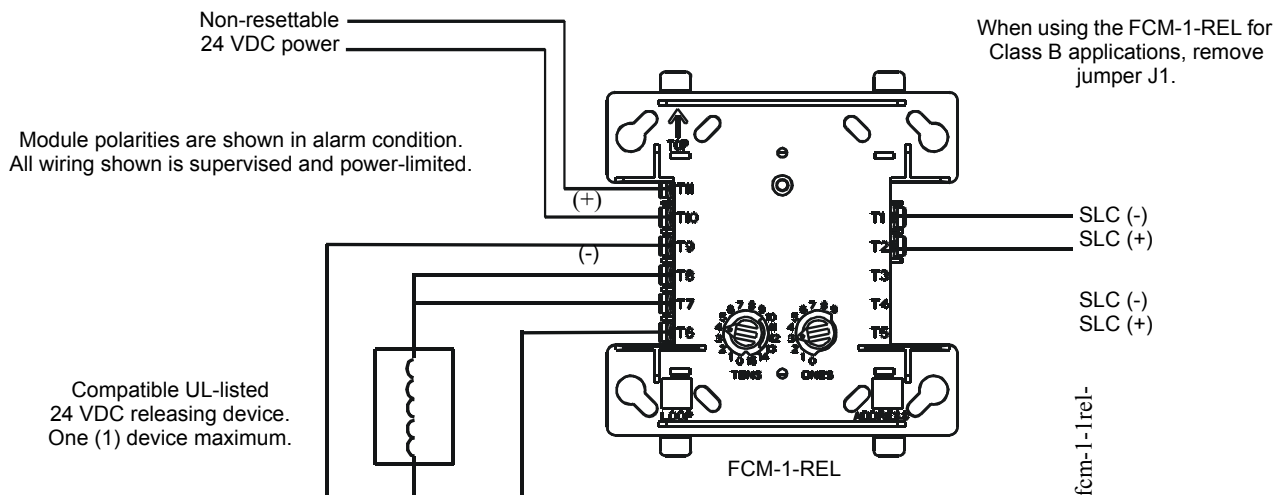


Figure 4.13 NPFA Class A Wiring of the FCM-1-REL

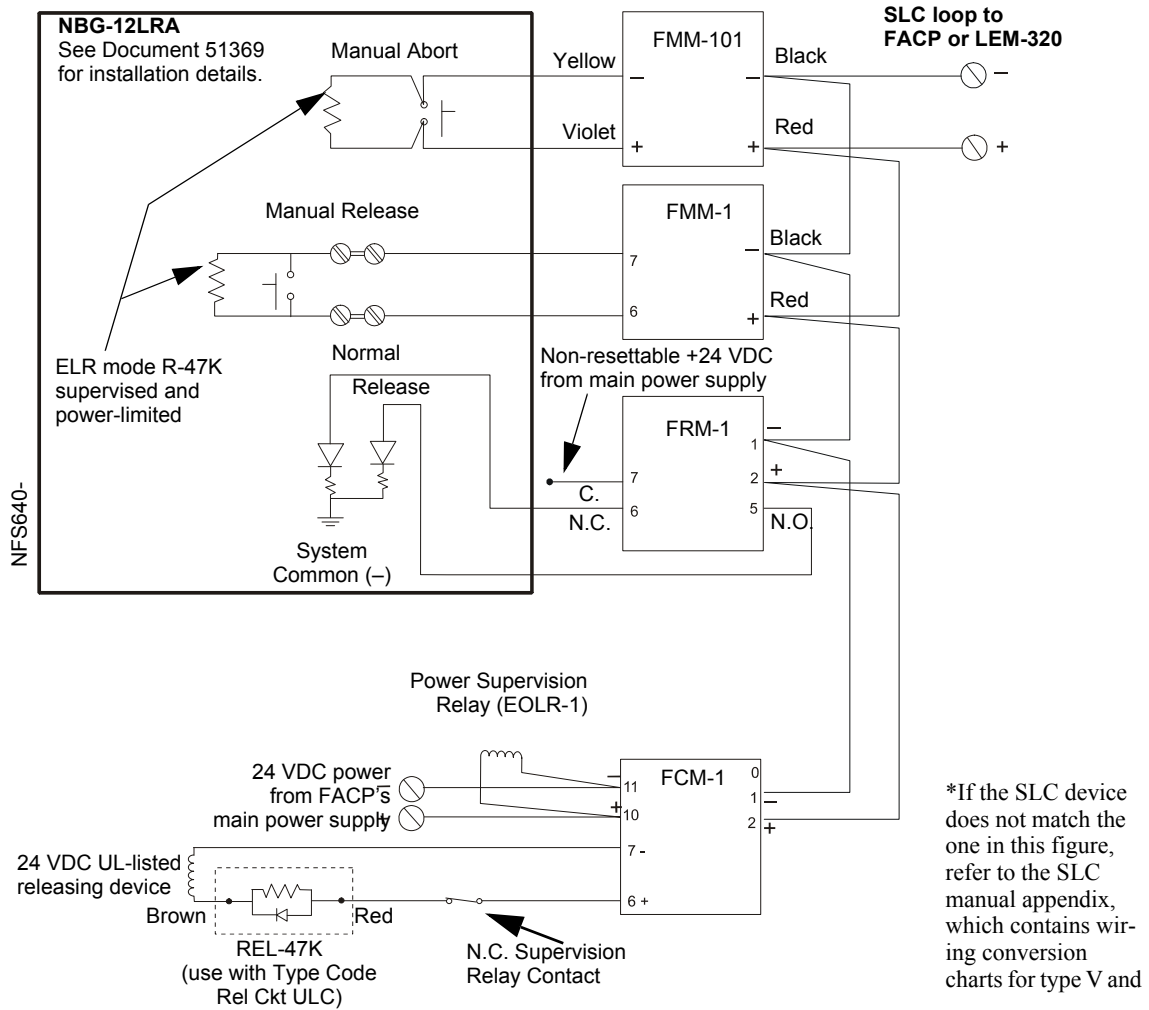
**NOTE:** With firmware version 12.0 or higher ALL new FlashScan Mode SLC releasing applications require the FCM-1-REL control module. The V-type FCM-1 control module may be used in SLC releasing applications with firmware version 14.0 or higher. H-type FCM-1 control modules do not support FlashScan Mode releasing applications with firmware version 14.0 or higher. Use H-type FCM-1 for CLIP mode SLC releasing applications, with firmware version 12.0 or higher.

**Critical Requirements.** When connecting a releasing device to the FCM-1-REL module, note the following:

1. See “Power Considerations” on page 52 for information on monitoring 24 VDC power.
2. Do not T-tap or branch a Class A or Class B circuit.
3. Only one (1) 24V solenoid or two (2) 12V solenoids in series can be connected to the FCM-1-REL.
4. Do not loop wiring under the screw terminals. Break the wire run to provide supervision of connections.
5. All applications using the FCM-1-REL are power-limited:
  1. Program the releasing circuit for Type Code REL CKT ULC or RELEASE CKT.
  2. Circuits are supervised against opens and shorts.
6. Refer to the *NFS2-640/E Programming Manual* for instructions on setting the Soak Timer.

The FCM-1-REL module must be programmed with the correct releasing type code listed in the *NFS2-640/E Programming Manual*.

### 4.7.6 Connecting an NBG-12LRA Agent Release-Abort Station



**Figure 4.14 Typical Connections for an NBG-12LRA Agent Release-Abort Station**



**NOTE:** If using the on-board NACs, see Circuit Requirements for Section 4.7.3 “Connecting a Releasing Device to the Control Panel” on page 49. If using FCM-1, see Circuit Requirements for Section 4.7.4, “Connecting a Releasing Device to the FCM-1 Module”, on page 51. If using the FCM-1-REL, see Circuit Requirements for Section 4.7.5, “Connecting Releasing Devices to the FCM-1-REL Control Module”, on page 53.

## Section 5: Testing the System

### 5.1 Acceptance Test

When finished with the original installation and all modifications, conduct a complete operational test on the entire installation to verify compliance with applicable NFPA standards. Testing should be conducted by a factory-trained fire alarm technician in the presence of a representative of the Authority Having Jurisdiction and the owner's representative. Follow procedures outlined in NFPA Standard 72's section on *Inspection, Testing and Maintenance*.

### 5.2 Periodic Testing and Service

Periodic testing and servicing of the control panel, all initiating and notification devices, and any other associated equipment is essential to ensure proper and reliable operation. Test and service the control panel as required by the Authority Having Jurisdiction and according to the schedules and procedures outlined in the following documents:

- NFPA Standard 72's section on *Inspection, Testing and Maintenance*.
- Service manuals and instructions for the peripheral devices installed in the system. Correct any trouble condition or malfunction immediately.

### 5.3 Operational Checks

Before proceeding: a) notify the fire department and the central alarm receiving station if transmitting alarm conditions; b) notify facility personnel of the test so that alarm sounding devices are disregarded during the test period; and c) when necessary, disable activation of alarm notification appliances and speakers to prevent their sounding.

- Disconnect all releasing devices to prevent accidental activation in accordance with NFPA 2001 and NFPA 12A releasing agents.



---

**WARNING:**

Do not rely on disable/enable software settings to lockout releasing devices.

---

- Check that the green POWER LED lights.
- Check that all status LEDs are off.
- Press and hold the LAMP TEST key. Verify that all LEDs and all LCD display segments work.
- Activate an Initiating Device Circuit using an alarm initiating device or an addressable initiating device on the SLC and check that all programmed active notification appliances function. Reset the alarm initiating device, the control panel, and any other associated equipment. In voice alarm applications, confirm that the proper tone(s) and/or messages sound during alarm conditions. Select the paging function and confirm that the message can be heard in the affected fire zones. Repeat the above step with each Initiating Device Circuit and each addressable device.
- On systems equipped with a fire fighter's telephone circuit, make a call from a telephone circuit and confirm a ring tone. Answer the call and confirm communication with the incoming caller. End the call and repeat for each telephone circuit in the system.
- Remove AC power, activate an Initiating Device Circuit through an alarm initiating device or an addressable initiating device on the SLC, and check that programmed active notification appliances sound, and alarm indicators illuminate. Measure the battery voltage with notification appliances active. Replace any battery with a terminal voltage less than 21.6 VDC and reapply AC Power.



---

**NOTE:** The battery test requires fully charged batteries. If batteries are new or discharged due to a recent power outage, allow the batteries to charge for 48 hours before testing.

---

- Return all circuits to their pretest condition.
- Check that all status LEDs are off and the green POWER LED is on.
- Notify fire, central station and/or building personnel when you finish testing the system.

### 5.4 Battery Checks and Maintenance

Maintenance-free sealed lead-acid batteries used in the system do not require the addition of water or electrolyte. These batteries are charged and maintained in a fully charged state by the main power supply's charger during normal system operation. A discharged battery typically reaches the voltage of 27.6 VDC within 48 hours; the charge rate depends on the battery size (2.0A for 18-26AH; 5.0A-5.7A for 26AH-200AH).

Batteries should be replaced in accordance with the battery manufacturer's recommendations. Immediately replace a leaking or damaged battery.



---

**WARNING:**

Batteries contain Sulfuric Acid which can cause severe burns to the skin and eyes and damage to fabrics.

---

- If a battery leaks and contact is made with the Sulfuric Acid, immediately flush skin and/or eyes with water for at least 15 minutes. Water and household baking soda provides a good neutralizing solution for Sulfuric Acid.
- If Sulfuric Acid gets into eyes, seek immediate medical attention.
- Ensure proper handling of the battery to prevent short circuits.

- Take care to avoid accidental shorting of the leads from uninsulated work benches, tools, bracelets, rings, and coins.

**WARNING:**

Shorting the battery leads can damage the battery, equipment, and could cause injury to personnel.



## Appendix A: Power Supply Calculations

Calculations must be done to determine standby and alarm DC current loads. Ampere-hour requirements must be calculated as well to determine battery size. The on-board power supply provides filtered 24VDC power that may be used for operating external devices. Use Table A.2 to determine if external loading is within the capabilities of the power supply.

### A.1 Calculating AC Branch Circuit Current

Use Table A.1 below to determine the total amount of current, in AC amperes, that a 120 VAC, 50/60 Hz service must be able to supply to the fire alarm system. Devices rated for 240 VAC operation will draw approximately one-half the current listed in Table A.1.

Device Type	No. of Devices		Current (amps)		Total Current
CPS-24 Power Supply	[ 1 ]	X	5.0	=	5.0
CPS-24/E Power Supply	[ .. ]	X	2.5A	=	
AA-30	[ ]	X	1.00	=	
AA-120	[ ]	X	1.85	=	
FCPS-24S6/S8	[ ]	X	3.2	=	
ACPS-2406	[ ]	X	2.7*	=	
ACPS-610	[ ]	X	5.0*	=	
ACPS-610/E	[ ]	X	2.5	=	
APS-6R	[ ]	X	2.5	=	
CHG-120	[ ]	X	2.0	=	
Sum column for AC Branch Current required=amps					

**Table A.1 120 VAC Fire Alarm Circuit**

\* Separate calculations are required for any devices powered by the ACPS-2406 and ACPS-610. It has its own integral battery charger and batteries can be connected directly to it. Refer to the ACPS-2406 or ACPS-610 Installation Manuals for battery calculations.

AC Branch Circuit Installation: For guidelines on wiring the AC branch circuit current, see “Operating Power: AC Branch Circuit” on page 72 in Appendix B.1 “Electrical Specifications”.

### A.2 Calculating the System Current Draws

The control panel’s main power supply must be able to power all internal system devices (and several types of external devices) continuously during non-fire alarm conditions. Use column 1 in Table A.2 to calculate the Non-Fire Alarm Load on the power supply regulator when applying primary power. The main power supply must also provide a finite amount of additional current during a fire alarm condition. Use column 2 in Table A.2 to calculate the additional current needed during fire alarms. The requirements for non-fire alarm and fire alarm current loads cannot exceed the capabilities of the power supply as listed below:

- 4.4 A at 24 VDC during Standby; and
- 7.4 A at 24 VDC during Alarm.

The current draw from all NACs plus DC output from TB10 and TB2 is 3.0 A during standby and 6.0 A during alarm.

#### How to Use the Calculating Tables

As used in this section, “Primary” refers to the control panel’s on-board power supply, its primary source of AC power. “Secondary” refers to the control panel’s backup batteries (or any other 24 VDC power supply listed for Fire Protective Signaling and connected in place of the batteries). The term “standby” refers to the output current required when no fire alarm is present. The term “alarm” refers to the output current required when a fire alarm is present.

The Primary Power Source Non-Alarm Current and Alarm Current columns are DC current calculations. These calculations confirm that the power supply can provide enough current to support the system during Primary Non-Fire Alarm and Fire Alarm conditions.

**Quantities** List the number of devices powered by the FACP and its power supply. Devices powered by the Accessories Output (TB10 and TB2) draw current directly from the panel. Devices powered by the Panel Output draw current through the fire panel’s connection to the power supply. Use these quantities to calculate total current draw of each set of devices in calculation columns 1, 2, and 3.

**Calculation Column 1 (Primary, Non-Fire Alarm Current in amps)** Add the contents of calculation column 1 to get the current drawn from the power supply during a non-alarm condition, with AC power applied. This current draw cannot exceed 4.4 A without an auxiliary power supply.

**Calculation Column 2 (Primary, Fire Alarm Current in amps)** Calculation column 2 lets the system designer determine the current load that the power supply must support during a fire alarm. The total current draw during a fire alarm cannot exceed 6 A without an auxiliary power supply.

Typically, a system should contain capacity to activate all output circuits and relays, and support fire alarms on no less than 10% of Initiating Device Circuits, subject to the requirements of the Authority Having Jurisdiction (AHJ).

The Control Panel provides power for Notification Appliance Circuits. Refer to the Device Compatibility Document for 24 VDC notification appliances that are UL- and ULC-listed for fire alarm systems.

**Calculation Column 3 [Secondary (Battery) Non-Alarm Current]** Column 3 lets the system designer calculate the non-fire alarm current drawn from the secondary source in a non-fire alarm condition during AC power loss. The non-fire alarm current is required to complete the standby battery calculations. After summing all current draws, insert the total in Table A.3.

Category	Calculation Column 1 Primary, Non-Fire Alarm Current (amps)			Calculation Column 2 Primary, Fire Alarm Current (amps)			Calculation Column 3 Secondary, Non-Fire Alarm Current (amps)		
	Qty	X [current draw]=	Total	Qty	X [current draw]=	Total	Qty	X [current draw]=	Total
CPU2-640/E	1	x [0.250]=		1	x [0.250]=		1	x [0.250]=	
# NACs in use (0, 1, 2, 3 or 4)*	[ ]	x [0.035]		[ ]	x [0.035]		[ ]	x [0.035]	
CPS-24/E	n/a	n/a		n/a	n/a		n/a	x [0.040]	
KDM-R2 (Backlight on)	[ ]	x [0.100]=		[ ]	x [0.100]=		[ ]	x [0.100]=	
LEM-320	0 / 1	x [0.100]=		0 / 1	x [0.100]=		0 / 1	x [0.100]=	
SLC loop†:	1/2	x [.200]=		1/2	x [.200]=		1/2	x [.200]=	
NCA, NCA-2 (Back light ON)	[ ]	x [0.400]=		[ ]	x [0.400]=		[ ]	x [0.400]=	
NCA, NCA-2 (Back light OFF)	[ ]	x [0.200]=		[ ]	x [0.200]=		[ ]	x [0.200]=	
NCM-W, NCM-F	[ ]	x [0.110]=		[ ]	x [0.110]=		[ ]	x [0.110]=	
HS-NCM-W/MF/SF/WMF/WSF/ MFSF	[ ]	x [0.400]=		[ ]	x [0.400]=		[ ]	x [0.400]=	
TM-4	[ ]	x [ ]=		[ ]	x [ ]=		[ ]	x [ ]=	
DPI-232 (Refer to manual**)									
APS-6R							[ ]	x [0.025]=	
APS2-6R							[ ]	x [0.0013]=	
ACPS-2406, ACPS-610									
DVC components (Refer to manual**)	[ ]	x [ ]=		[ ]	x [ ]=		[ ]	x [ ]=	
	[ ]	x [ ]=		[ ]	x [ ]=		[ ]	x [ ]=	
AA-30							[ ]	x [0.045]=	
AA-100, AA-120							[ ]	x [0.050]=	
ACM-24AT	[ ]	x [0.016]=		[ ]	x [0.070]=		[ ]	x [0.016]=	
ACM-48A	[ ]	x [0.016]=		[ ]	x [0.070]=		[ ]	x [0.016]=	
AEM-24AT	[ ]	x [0.002]=		[ ]	x [0.056]=		[ ]	x [0.002]=	
AEM-48A	[ ]	x [0.002]=		[ ]	x [0.056]=		[ ]	x [0.002]=	
Maximum number of LEDs illuminated on these annunciators during non-fire conditions:	[ ]	x [0.0054]=					[ ]	x [0.0054]=	
AFM-16AT, AFM-32A	[ ]	x [0.040]=		[ ]	x [0.056]=		[ ]	x [0.040]=	
ACM-16AT, ACM-32A	[ ]	x [0.040]=		[ ]	x [0.056]=		[ ]	x [0.040]=	
AEM-16AT, AEM-32A	[ ]	x [0.002]=		[ ]	x [0.018]=		[ ]	x [0.002]=	
AFM-16A	[ ]	x [0.025]=		[ ]	x [0.065]=		[ ]	x [0.025]=	
ACM-8R (refer to manual**)	[ ]	x [ ]=		[ ]	x [ ]=		[ ]	x [ ]=	
LDM (refer to manual**)	[ ]	x [ ]=		[ ]	x [ ]=		[ ]	x [ ]=	
FDU-80 LCD-80, LCD2-80	[ ]	x [0.0643]=		[ ]	x [0.0643]=		[ ]	x [0.0643]=	
	[ ]	x [0.100]=			x [0.100]=			x [0.050]=	
AMG-1, AMG-E	[ ]	x [0.060]=		[ ]	x [0.060]=		[ ]	x [0.060]=	
RM-1	[ ]	x [0.020]=		[ ]	x [0.020]=		[ ]	x [0.020]=	
FZM-1, MMX-2	[ ]	x [0.0094]=		[ ]	x [0.090]=		[ ]	x [0.0094]=	

**Table A.2 System Draw Current Calculations (1 of 2)**

Category	Calculation Column 1 Primary, Non-Fire Alarm Current (amps)	Calculation Column 2 Primary, Fire Alarm Current (amps)	Calculation Column 3 Secondary, Non-Fire Alarm Current (amps)
RPT-W, RPT-WF, RPT-F RPT-485W, RPT-485WF	[ ] x [0.017]=	[ ] x [0.017]=	[ ] x [0.017]=
UDACT Communicator	[ ] x [0.040]=	[ ] x [0.100]=	[ ] x [0.040]=
UDACT-2 Communicator	[ ] x [0.052]=	[ ] x [0.087]=	[ ] x [0.052]=
NFV-25/50 (see manual**)	[ ] x [ ]=	x [ ]=	x [ ]=
Four-Wire Smoke Detectors <sup>‡</sup>	[ ] x [ ]=	[ ] x [ ]=	[ ] x [ ]=
Power Supervision Relay EOLR-1	[ ] x [0.020]=	[ ] x [0.020]=	[ ] x [0.020]=
FWSG (only if powered by the FWSG 24V connections TB:A2 and TB:A3)	[ ] x [0.040]=	[ ] x [0.040]=	[ ] x [0.040]=
Notification Appliance powered from Main Power Supply**		[ ] x [ ]=	
		[ ] x [ ]=	
DHX-501, FSD-751RP, FSD- 751RPL (Duct Detectors with internal relays) Refer to installation document	[ ] x [ ]=	[ ] x [ ]=	[ ] x [ ]=
	[ ] x [ ]=	[ ] x [ ]=	[ ] x [ ]=
CHG-120 Battery Charger			[ ] x [0.060]=
Local Energy Municipal Box		[ ] x [ ]=	
Compatible Devices not listed above <sup>††</sup>	[ ] x [ ]=	[ ] x [ ]=	[ ] x [ ]=
	[ ] x [ ]=	[ ] x [ ]=	[ ] x [ ]=
Sum each column for totals	Primary, non-alarm: [ ]	Primary, alarm: [ ]	Secondary, non-alarm: [ ]

**Table A.2 System Draw Current Calculations (2 of 2)**

\* Maximum current draw for all NACs plus DC output from TB10 and TB2 is 3.0 A during standby.

† Value represents an SLC's maximum current draw. Refer to device datasheets for individual current draws.

‡ The total regulated load current supplied to four-wire smoke detector and power supervision relays cannot exceed 1.25 A.

\*\* Enter the total notification appliance draw from the Main Power Supply, excluding the current from APS-6R supplies. Refer to Device Compatibility Document.

†† Refer to manual and/or Device Compatibility Document. See Table 1.1, "Reference Documentation," on page 8 for specific documentation part numbers.

### A.2.1 Calculating the Maximum Secondary Power Fire Alarm Current Draw

Use Table A.3 below to determine the maximum current requirements of secondary power source during fire alarm conditions. The result obtained is the amount of current that the batteries must be able to supply to the fire alarm system. Use the result in Table A.4 to determine the size of the batteries needed for the fire alarm system.

Results taken from Table A.3 below assume that, while in a fire alarm condition, batteries must feed the main power supply (and any additional supplies such as the APS-6R and AA-30) with the maximum rated power each supply can provide.

Device	Quantity	Current (in amps)	Total Current/Type
Alarm Current, from Table A.2, col 2		=	
APS-6R*	[ ]	X 6	=
APS2-6R	[ ]	6	=
AA-30 <sup>†</sup>	[ ]	X 3	=
AA-120	[ ]	X 7.3	=
Sum Column for Secondary Fire Alarm Load		=	[ ]

**Table A.3 Maximum Secondary Power Fire Alarm Current Draw**

\* Actual load current may be used in place of maximum rated supply current. To calculate actual load current, sum the current draws for each appliance connected to APS-6R supplies.

† Exclude Amplifiers that are employed for backup.



**NOTE:** The Secondary Fire Alarm Load cannot exceed the following:  
12 A with BAT-12260 batteries (12 V, 26 AH).  
20 A with BAT-12550 batteries (12 V, 55 AH).

## A.3 Calculating the Battery Requirements

### A.3.1 Calculating the Battery Capacity

Use this table to determine the battery capacity needed for the system:

Current (amps)	X	Time (hours)	=	AH
Secondary Non-Fire Alarm Current (from column 3 in Table A.2) (see Note 8)	X	Required Secondary Non-Fire Alarm Standby Time (24 or 60 hours)	=	_____ AH
APS-6R Standby Load Current	X	Required Secondary Non-Fire Alarm Standby Time (24 or 60 hours)	=	_____ AH
Secondary Fire Alarm Load (from Table A.3) (see Note 8)	X	Required Fire Alarm Standby Time: (for 5 minutes, enter 0.084; for 15 minutes, enter 0.25)	=	_____ AH
Sum Column for Total Secondary Amp Hours calculated			=	_____ AH
Multiply by the derating factor x 1.2 (see Note 7)			=	_____ AH
Battery Size – Total Secondary Amp Hours Required			=	_____ AH
<ol style="list-style-type: none"> <li>NFPA 72 Local, Proprietary, and Central Station systems require 24 hours of standby power followed by 5 minutes in alarm.</li> <li>NFPA 72 Auxiliary and Remote Station Systems require 24 hours of standby power followed by 5 minutes in alarm.</li> <li>Batteries installed in a system powered by an automatic starting engine generator need to provide at least 4 hours of standby power.</li> <li>Factory Mutual requires 90 hours of standby for deluge-preaction systems.</li> <li>Emergency voice/alarm communications systems require 2 hours of operation in the alarm condition. Due to the sporadic nature of voice operation, however, NFPA 72 permits 15 minutes of operation at a maximum connected load to equal 2 hours of normal use.</li> <li>If the total exceeds 26 AH, the system requires a separate NFS-LBB, BB-100 or BB-200 battery enclosure for two larger capacity batteries.</li> <li>The following battery derating factors must be used for Canadian installations using NFS2-640/E charger: <ul style="list-style-type: none"> <li>For a 26 AH battery, use derating factor of 1.5</li> <li>For a 55 AH battery, use derating factor of 1.8</li> <li>For a 100 AH battery, use derating factor of 2.5</li> <li>For a 200 AH battery, use derating factor of 2.5</li> </ul> </li> <li>For 26 AH batteries: maximum standby current cannot exceed 0.65A; maximum alarm current cannot exceed 6.75A.</li> </ol>				

**Table A.4 Secondary Power Standby and Fire Alarm Load**

### A.3.2 Calculating the Battery Size

Use this table to choose the battery size, in amp-hours, needed to support the fire alarm system.

The CPS-24/E can charge batteries from 18 to 200 AH. Select batteries that meet or exceed the Total Amp-Hours calculated in Table A.4 and that are within the acceptable battery charger range. Write the amp-hours requirements on the Protected Premises label.

The maximum battery size that can be mounted inside a CAB-4 series backbox is 26AH.

Battery Size	Voltage Rating	Number Required	Our Part Number	Backbox Part Number <sup>†</sup>
18 AH	12 volts	two	BAT-12180	SBB-A4*, SBB-B4*, SBB-C4*, SBB-D4*, BB-25
26 AH	12 volts	two	BAT-12260	SBB-A4, SBB-B4, SBB-C4, SBB-D4, BB-25
100 AH	12 volts	four for 100 AH two for 200 AH	BAT-121000	BB-100 BB-200
*Manufactured to our specifications. <sup>†</sup> Red version available; add "R" to part number listed here				

**Table A.5 Selecting Battery and Battery Backbox**

## Appendix B: Electrical Specifications

### B.1 Electrical Specifications

#### AC Power

Component	Values
Main Power Supply	120 VAC, 50/60 Hz, 5.0 A; or 240 VAC, 50/60 Hz, 2.5 A
Wire size	Maximum 12 AWG (3.31 mm <sup>2</sup> ) with 600 VAC insulation



**NOTE:** If using an auxiliary power supply such as FCPS-24S6/S8, APS-6R, ACPS-2406, or ACPS-610, or audio amplifiers, refer to the documentation for that equipment.

#### Batteries

The control panel uses **only** sealed lead-acid batteries for secondary standby power. Maximum battery capacity for the CPS-24/E main power supply is 200 AH. CAB-4 Series backboxes provide space for two 26 AH (or smaller) batteries. Use external battery boxes if the installation requires larger capacity batteries; see Table A.5, “Selecting Battery and Battery Backbox,” on page 58.

The table below contains battery charger specifications.

Charger	Description	Specifications
CPS-24/E Main Power Supply	An internal battery charger for 18 AH to 200 AH	Normal Charge: 27.6 VDC +/- 0.24 VDC Charging Current: 2.0 A or 5.7 A (Software selectable)
CHG-120 Battery Charger	An external battery charger designed to charge lead-acid batteries between 26 AH and 120 AH	Dual Rate: High Charge: 28.1 VDC Normal Charge: 27.6 VDC Charging Current: 4.5 A
ACPS-2406 Auxiliary Charger/Power Supply	An internal battery charger for 7AH to 26 AH	Normal Charge: 27.6 VDC Charging Current: 1.1 A max (0.750 A typical)
ACPS-610 Addressable Charger/Power Supply	An internal battery charger for 12AH to 200AH	Normal Charge: 27.6 VDC +/- 0.24 VDC Charging Current: 2A, 5A, or OFF (Software Selectable)

#### Signaling Line Circuit (SLC)

Item	Value
Voltage	24 VDC nominal, 27.6 VDC maximum
Maximum length	12,500 ft. (3810 m) total loop or circuit length (NFPA Class A, B, and X) Note: Refer to Appendix B.2 “Wire Requirements” for limitations.
Maximum current	400 mA peak, 200 mA average (max short circuit; circuit will shut down until short is fixed). For battery calculation purposes use 200mA.
Maximum resistance	50 ohms (supervised and power-limited)

#### Notification Appliance Circuits & Releasing Circuits

Item	Value
Max. wiring voltage drop	2 VDC (Retrofit note: SLCs with old CMX modules are restricted to 1.2 VDC.)
NAC Nominal operating voltage	24 VDC regulated, 1.5 A max.
Special Applications for Releasing Circuits	20.16 - 26.42 VDC
Current for all external devices connected to the control panel's power supply	6.0 A in alarm (3 A continuous) TB2, TB10 and all 4 NACs share a maximum of 3.0 A in standby and 6.0 in alarm.
Optional ACPS-2406	Total 6 A in alarm (5 A continuous)
Optional ACPS-610	Total 6 A in alarm (1.5 A single output)
Optional APS-6R	Total 6 A in alarm (4 A continuous)
End-of-Line Resistors (ELRs)	Control Panel NACs (TB6, TB7, TB8, TB9): 2.2K, 1/2 watt XP6-C, FCM-1 Modules: 47K, 1/2 watt
NOTE: For a list of compatible Notification Appliance Circuits and Releasing Circuits see Notifier Device Compatibility Document 15378.	

## Output Relays

Output relays for Alarm and Trouble are common on TB4; Supervisory and Security are programmable on TB5. See Figure 3.21, “Form-C Relay Connections” on page 39).

Contact ratings: 2.0 A @ 30 VDC (resistive)

## Four-wire Smoke Detector Power

Control Panel terminals TB10 RESET (+) and (–) supply filtered, low-noise power for four-wire smoke detectors. Specifications are:

- Nominal voltage: 24 VDC special applications.
- Maximum rated current: 1.25 A DC
- Maximum ripple voltage: 176 mVrms
- TB10, TB2, and all 4 NACs share a maximum of 3.0 A in standby and 6.0 A in alarm.

Refer to the *Device Compatibility Document* for compatible 24 VDC detectors.

## Power Output

Control Panel terminals TB10 NONRESET (+) and (–) supply one (1) power-limited circuit available to power external devices, such as notification appliances and annunciators.

- Nominal voltage: 24 VDC regulated, special applications, 1.5 A max.
- Maximum rated current: 1.25 A DC
- Maximum ripple voltage: 176 mVrms
- TB10, TB2, and all 4 NACs share a maximum of 3.0 A in standby and 6.0 A in alarm.

Refer to the *Device Compatibility Document* for compatible devices and notification appliances.



**NOTE:** The Control Panel provides a total of 7.4 A of power in alarm (4.4 A in standby), shared by all internal circuitry and external provisions (24 V resettable and non-resettable). TB10 and all 4 NACs share a maximum of 3.0 A in standby and 6.0 A in alarm. For power requirements, refer to the power supply calculation tables in Appendix A.

## Operating Power: AC Branch Circuit

The control panel requires connection to a separate dedicated AC branch circuit. Follow these guidelines when connecting the AC branch circuit:

- Label the branch circuit “Fire Alarm”. This must be a separate dedicated AC fire alarm circuit.
- Connect the branch circuit to the line side of the main power feed of the protected premises.
- Do not power other equipment from the fire alarm branch circuit.
- Run the AC branch circuit wire continuously, without any disconnect devices except for overcurrent protection, from the power source to the fire alarm control panel.
- Overcurrent protection for the AC branch circuit must comply with Article 760 of the National Electrical Codes, as well as local codes.
- Use 12 AWG (3.31 mm<sup>2</sup>) wire with 600 VAC insulation for the AC branch circuit.

Connect the ground terminal (TB1-Earth) to a solid earth ground (a metallic, cold water pipe may be suitable in some installations). This connection is vital in reducing the panel’s susceptibility to transients generated by lightning and electrostatic discharge.

## Operating Power: Secondary Power Source (Batteries)

The battery charger is current-limited and can recharge sealed lead-acid type batteries. The battery charger shuts off when the control panel is in alarm.

## B.2 Wire Requirements

Each type of circuit within the Fire Alarm Control System requires use of a specific wire type to ensure proper circuit operation. The wire gauge of a particular circuit depends on the length of that circuit and the current traveling through it. Use Table B.1 below to determine the specific wiring requirements for each circuit.

Compliance with the Federal Communications Commission (FCC) and Canadian Department of Communication regulations on electrical energy radiation requires the following: Use twisted-pair shielded wire for any non-SLC-loop wiring entering or exiting the cabinet that is not enclosed in conduit. Use twisted-pair unshielded wiring for SLC-loop wiring.



**NOTE:** If running an SLC in conduit with Notification Appliance Circuits, you can reduce problems by exclusively using electronic sounders (such as the SpectrAlert, SpectrAlert Advanced or MA/SS-24 Series) instead of more electronically noisy notification appliances (such as electromechanical bells or horns).

Circuit Type	Circuit Function	Wire Requirements	Distance (feet/meters)	Typical Wire Type
SLC (power limited)	Connects to intelligent and addressable modules.	Twisted-unshielded pair, 12 to 18 AWG (3.31 to 0.82 mm <sup>2</sup> ). 50 ohms maximum per length of Class A & X loops. 50 ohms per branch maximum for Class B loop.	12,500 ft. (3,810 m) 9,500 ft. (2,895.6 m) 6,000 ft. (1,828.8 m) 3,700 ft. (1,127.76 m)	12 AWG (3.31 mm <sup>2</sup> ) 14 AWG (2.08 mm <sup>2</sup> ) 16 AWG (1.31 mm <sup>2</sup> ) 18 AWG (0.82 mm <sup>2</sup> )
		Twisted, shielded pair NOTE: • Shields must be isolated from ground. • Shields should be broken at each device.	5,000 ft. (1,524 m) 3,700 ft. (1,127.76 m)	12 to 16 AWG (3.31 to 0.82 mm <sup>2</sup> ) 18 AWG (0.82 mm <sup>2</sup> )
		Untwisted, unshielded wire, in conduit or outside of conduit.	5,000 ft. (1,524 m) 3,700 ft. (1,127.76 m)	12 to 16 AWG (3.31 to 0.82 mm <sup>2</sup> ) 18 AWG (0.82 mm <sup>2</sup> )
		Note: Maximum total capacitance of all SLC wiring (both between conductors and from any conductor to ground) should not exceed 0.5 microfarads.		
EIA-485 (power limited)	Connects to FDU-80, ACS modules, LCD-80, or TM-4 Transmitter	Twisted-shielded pair with a characteristic impedance of 120 ohms. 18 AWG (0.82 mm <sup>2</sup> ) minimum.	6,000/1829 (max)	16 AWG (1.31 mm <sup>2</sup> )
EIA-232 (power limited)	Connects to Printers, CRT, or PC.	Twisted-shielded pair in conduit. 18 AWG (0.82 mm <sup>2</sup> ) minimum.	20 feet (6.1 m) (without modem)	16 AWG (1.31 mm <sup>2</sup> )
IDC Initiating Device Circuit	FMM-1, FMM-101, <b>FDM-1XP10-M</b> , XP6-MA (power limited)	12-18 AWG (3.31 to 0.82 mm <sup>2</sup> ). Maximum circuit resistance is 20 ohms.		12 to 18 AWG (3.31 to 0.82 mm <sup>2</sup> )
NAC Notification Appliance Circuit	FCM-1*, XP6-C (power limited)	12-18 AWG (3.31 to 0.82 mm <sup>2</sup> ). At alarm current level, no more than a 1.2 V drop at the end of the circuit, or sized to provide the minimum rated operating voltage of the appliances used.	.To meet 1.2 V drop, or sized to provide the minimum rated operating voltage of the appliances used.	12 to 18 AWG (3.31 to 0.82 mm <sup>2</sup> )
Releasing Module	FCM-1-REL	12-18 AWG (3.31 to 0.82 mm <sup>2</sup> ). 5 ohms maximum per circuit for class A or B, or sized to provide the minimum rated operating voltage of the appliances used.	To meet 5 ohms maximum circuit resistance, or sized to provide the minimum rated operating voltage of the appliances used	12 to 18 AWG (3.31 to 0.82 mm <sup>2</sup> )
24 VDC Power Runs (power-limited)	To TM-4 Transmitter, Annunciator and FCM-1 modules	12-18 AWG (3.31 to 0.82 mm <sup>2</sup> ). Size wire so that no more than 1.2 V drop across wire run from supply source to end of any branch.	To meet 1.2 volt drop	12 to 18 AWG (3.31 to 0.82 mm <sup>2</sup> )
CHG-120	External battery charger	12 AWG (3.31 mm <sup>2</sup> ) in conduit	20/6.1 (max)	12 AWG (3.31 mm <sup>2</sup> )
Note: * FCM-1 cannot be used for synchronized strobe/sounder applications.				

Table B.1 Wire Requirements



**NOTE:** Lightning arresters required on circuits extending between buildings; 999 meter length maximum to meet UL 60950.

## Appendix C: Canadian Applications

### C.1 Standalone Application

#### C.1.1 NFS2-640/E with KDM-R2

If using KDM-R2 as the primary display for NFS2-640/E, an ACS series annunciator must be mounted adjacent to the panel or within NFS2-640/E enclosure.

#### C.1.2 NFS2-640/E with NCA-2

Network Control Annunciator (NCA-2) with 640-character, multi-line display complies with ULC requirements when used as the primary display for NFS2-640/E.

### C.2 Network Applications

To meet ULC requirements, the network's Manual Controls may only be operated from one location at any given time. When panels are networked (using NCM Network Communications Modules or High-Speed Network Communications Modules), use AKS-1B Key Switch on each panel's Primary Annunciator to enable its functions. NCA-2 may be a Primary Annunciator when AKS-1B is installed. Refer to the *NCA-2 Manual* for more information.

The NCA-2 or ONYXworks may be employed as a Display and Control Center. In the event that communication fails between the panels and the Control Center, the panels will continue to function in local/standalone mode.

### C.3 Automatic Alarm Signal Silence

If selecting this feature for a system requiring annunciators, consult the Authority Having Jurisdiction.

If Auto Silence is enabled, the value must be set to 20 minutes. An ACS point is required to monitor special function zone ZF40.

Activation of Auto Silence will activate the Signal Silence LED on the fire panel display and any ACM LED point programmed for Auto Silence.

### C.4 Annunciator Applications

1. In Canada, the ACM series annunciator modules must be used to annunciate the fire alarm input points/zones only, if no multi-line sequential display is installed.
2. For Canadian applications, the following LED colors must be employed:
  - Red must be used to indicate active alarm inputs.
  - Yellow must be used to indicate supervisory, burglary, trouble signals, and Automatic Alarm Signal Cancel.
  - Green must be used to indicate the presence of power or an activated output.
3. Two Stage Systems (3/5 minute timer) - ACM-24AT control point is required for Automatic Alarm Signal Cancel. Acknowledge will not cancel the Two-Stage Timer. For applications using Two Stage with the ACPS-610, see the ACPS-610 manual for additional programming instructions.
4. The ACM point designated for Automatic Alarm Signal Cancel should be labeled as "Automatic Alarm Signal Cancel" or "Auto Alm Signal Cancel."
5. If the DCC option is enabled, an ACS point is required to monitor ZF36 for the panel itself as well as each DCC on the network.

### C.5 Releasing Devices

Supervision for shorts is required; use REL devices and type code REL CKT ULC.

(With on-board NACs, use REL-2.2K; with FCM-1 modules use REL-47K. Refer to Section 4.7.5 "Connecting Releasing Devices to the TC810S1000 Control Module" for details.)

### C.6 Ancillary Devices

Panel control functions (Acknowledge, Signal Silence, Reset, and Drill) will not function on ancillary devices such as the ACM-24-AT, FDU-80, or the LCD2-80. (Local acknowledge will function on the ancillary device to silence the piezo and steady the LEDs).

### C.7 Isolating NACs with Audio Isolator Modules

#### C.7.1 Description of Modules

The audio isolator modules described below may be used to isolate short circuits during alarm signaling. These modules are listed with ULC for use with the NFS2-640C.

- AIM-1 - This module provides isolation to a separate circuit on an audible notification riser. A short circuit on an AIM-1 NAC circuit will not disable other NACs circuits on the riser.
- RSM-1 - This module works the same as the AIM-1, with the exception that there is a silence button for in-suite operation. The silence button will silence the audible signal to the module's circuit for ten minutes during alarm. Resounding will occur automatically after ten minutes.



## Notes

# Index

## Numerics

24 VDC, *see* Power (DC)

## A

A77-716B, *see* Power Supervision Relay  
*Replaced by EOLR-1*

AC, *also see* Power 31

Acceptance Test 55

ACM-8R

Labeling Requirements 36

Agent Release-Abort Station 54

Alarm Relays, *see* Form-C Relays 35

Ancillary Devices 64

## B

Backup-Alarm Switches 35

Basic Equipment Packages 11

Batteries, *also see* Power: DC

Battery Calculations 57, 58, 59, 60

Battery Checks and Maintenance 55

Battery Specifications 61

Connections 31

Battery Plate 20

Battery plate 24

## C

Cabinets 15

Mounting 19

Canadian Applications 25, 64

Central Receiving Unit, *also see* UDACT Manual  
48

Chassis 27

Circuit Board, *see* CPU

Compatible Equipment 15

Components 13, 14

Control Panel Circuit Board, *see* CPU

CPS-24/E, *see* Power Supply

CPU

CPU-640 (120V operation) 11

CPU-640E (240V operation) 11

Drawing 11, 13, 14

Overview 11

CRTs 41

CRT/PRN Combination 41

CRT-2 Configuration 39

CRT-2 Function Keys and Parameters 41

Installation 37–41

## D

DC, *also see* Power 31

DVC 29

## E

Electrical Connections 30

Electrical Specifications 61

Ematch Protection Device 34

EOLR-1 *see* Power Supervision Relay

External Power Supervision 44

## F

FCM-1 51

FCM-1-REL 44, 53

Fire/Security Applications 47–48

FMM-1 48

Form-C Relays 35, 62

Four-wire Smoke Detector

Specifications 62

FSA-8000 Wiring

34

## I

Installation

Checklist 19

Preparation 18

## J

Jumper Locations 13, 14

## K

KDM-R2

Installation steps 24

Keltron, *also see* Printers 38

## L

LDM-R32

Non-Power-Limited Circuits 36

LED Locations 14

Lockout 55

Loop Expander Module

Installation Steps 28

## M

Main Power Supply, *see* Power Supply  
Maintenance 55

Microcontroller Failure 35

Mounting

LEM 29

MRD-1 9

MRD-1 Manual Releasing Disconnect Assembly  
17

Multiple Detector Operation 42

## N

NACs (Notification Appliance Circuits)

Backup Option 35

NAC Connections 33

Releasing Applications 35, 49, 50

Specifications 61

NBG-12LRA 54

NCA-2, *also see* Primary Display 11

NCD 21

Network 21

Networking 29

NFPA Applications

NFPA 72 Central or Remote Station Fire  
Alarm System 44

NFPA Applications (Overview) 44

Non-Power-Limited Circuits

UL Wiring Requirements 36

Notification Appliance Circuits, *see* NACs

## O

Operating Power 62

Operational Checks 55

Option Boards

Installation Steps 25

Output Relays

Connections 35, 62

Specifications 62

## P

Periodic Testing 55

Power

AC Power Checklist 31

AC Power Connections 31

AC Specifications 61

DC Power Connections 31, 32

Installation Steps 30

Power Specifications 30, 62

Power Supervision Relay 51

Power Supply Calculations 57, 58, 59, 60

Power-Limited Wiring Requirements 36

Primary Display 11, 25

primary display 24

Printers 41

Installation 37–41

Keltron Printer Connections 38

PRN Series Connections 37

PRN Settings 38

PRN/CRT Combination 41

Proprietary Security Alarm Applications  
Wiring 48

Protected Premises Unit 44

## R

Related Documentation 8

Relays, *see* Form-C Relays 35

Releasing Circuits

Connections 33

Releasing Applications 49–54

Releasing Applications, Canada 64

Specifications 61

Releasing Device

Connections 49

FCM-1 Connections 51

FCM-1-REL Connections 44, 53

## S

Security Relays, *see* Form-C Relays 35

Security Tamper Switch 47, 48

Service 55

SLC 28

SLC, *also see* SLC Wiring Manual 42

Specifications 61, 62

Specifications 61, 62

Stacker-Connector 29

Stand-Off Lengths **23**  
Stat-X  
    Device Wiring **34**  
STS-1, *also see* Security Tamper Switch **48**  
Supervisory and Security Contacts  
    -Configuring as Alarm Contacts **35**  
Supervisory Relays, *see* Form-C Relays **35**  
Supplemental Documentation **8**  
Switches  
    Backup-Alarm **35**  
    Switch Locations **13, 14**  
System  
    Description of Features **10**  
    Limitations **10**  
    Options **10**  
System Current Draws **57, 58, 59, 60**

## **T**

Terminal Block Locations **13, 14**  
Testing **55**  
TM-4, *also see* *TM-4 Installation Document* **28**  
Trouble Relays, *see* Form-C Relays **35**

## **U**

UL Non-Power-Limited Wiring Requirements **36**  
UL Requirements **36**

## **V**

VeriFire **43**

## **W**

Wiring  
    Proprietary Security Alarm Applications  
        **48**  
    Wire Requirements **62**

## Manufacturer Warranties and Limitation of Liability

**Manufacturer Warranties.** Subject to the limitations set forth herein, Manufacturer warrants that the Products manufactured by it in its Northford, Connecticut facility and sold by it to its authorized Distributors shall be free, under normal use and service, from defects in material and workmanship for a period of thirty six months (36) months from the date of manufacture (effective Jan. 1, 2009). The Products manufactured and sold by Manufacturer are date stamped at the time of production. Manufacturer does not warrant Products that are not manufactured by it in its Northford, Connecticut facility but assigns to its Distributor, to the extent possible, any warranty offered by the manufacturer of such product. This warranty shall be void if a Product is altered, serviced or repaired by anyone other than Manufacturer or its authorized Distributors. This warranty shall also be void if there is a failure to maintain the Products and the systems in which they operate in proper working conditions.

MANUFACTURER MAKES NO FURTHER WARRANTIES, AND DISCLAIMS ANY AND ALL OTHER WARRANTIES, EITHER EXPRESSED OR IMPLIED, WITH RESPECT TO THE PRODUCTS, TRADEMARKS, PROGRAMS AND SERVICES RENDERED BY MANUFACTURER INCLUDING WITHOUT LIMITATION, INFRINGEMENT, TITLE, MERCHANTABILITY, OR FITNESS FOR ANY PARTICULAR PURPOSE. MANUFACTURER SHALL NOT BE LIABLE FOR ANY PERSONAL INJURY OR DEATH WHICH MAY ARISE IN THE COURSE OF, OR AS A RESULT OF, PERSONAL, COMMERCIAL OR INDUSTRIAL USES OF ITS PRODUCTS.

This document constitutes the only warranty made by Manufacturer with respect to its products and replaces all previous warranties and is the only warranty made by Manufacturer. No increase or alteration, written or verbal, of the obligation of this warranty is authorized. Manufacturer does not represent that its products will prevent any loss by fire or otherwise.

**Warranty Claims.** Manufacturer shall replace or repair, at Manufacturer's discretion, each part returned by its authorized Distributor and acknowledged by Manufacturer to be defective, provided that such part shall have been returned to Manufacturer with all charges prepaid and the authorized Distributor has completed Manufacturer's Return Material Authorization form. The replacement part shall come from Manufacturer's stock and may be new or refurbished. THE FOREGOING IS DISTRIBUTOR'S SOLE AND EXCLUSIVE REMEDY IN THE EVENT OF A WARRANTY CLAIM.

Warn-HL-08-2009.fm

---

**NOTIFIER**  
12 Clintonville Road  
Northford, CT 06472-1610 USA  
203-484-7161  
[www.notifier.com](http://www.notifier.com)



