

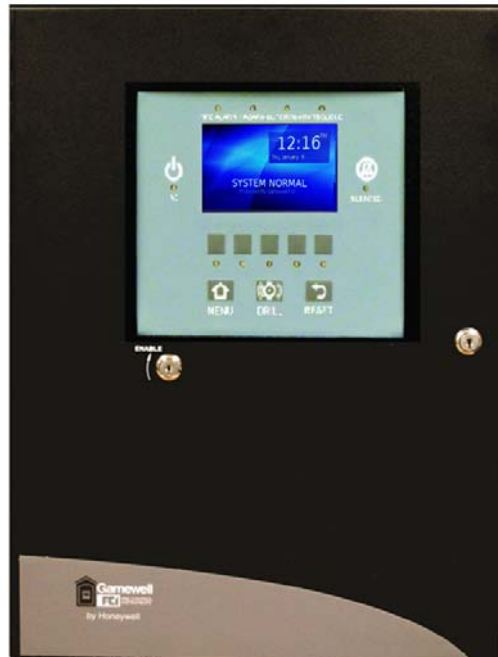

by Honeywell



# **S3 Series System** **(Small Addressable Fire Alarm Control Panel)** **Underwriters Laboratories** **Listing Document**

Document:LS10005-051GF-E  
3/09/2016 Rev: **D3**  
P/N LS10005-051GF-E:D3 ECN 15-0375

# Fire Alarm & Emergency Communication System Limitations

*While a life safety system may lower insurance rates, it is not a substitute for life and property insurance!*

**An automatic fire alarm system**—typically made up of smoke detectors, heat detectors, manual pull stations, audible warning devices, and a fire alarm control panel (FACP) with remote notification capability—can provide early warning of a developing fire. Such a system, however, does not assure protection against property damage or loss of life resulting from a fire.

**An emergency communication system**—typically made up of an automatic fire alarm system (as described above) and a life safety communication system that may include an autonomous control unit (ACU), local operating console (LOC), voice communication, and other various interoperable communication methods—can broadcast a mass notification message. Such a system, however, does not assure protection against property damage or loss of life resulting from a fire or life safety event.

The Manufacturer recommends that smoke and/or heat detectors be located throughout a protected premises following the recommendations of the current edition of the National Fire Protection Association Standard 72 (NFPA 72), manufacturer's recommendations, State and local codes, and the recommendations contained in the Guide for Proper Use of System Smoke Detectors, which is made available at no charge to all installing dealers. This document can be found at <http://www.systemsensor.com/appguides/>. A study by the Federal Emergency Management Agency (an agency of the United States government) indicated that smoke detectors may not go off in as many as 35% of all fires. While fire alarm systems are designed to provide early warning against fire, they do not guarantee warning or protection against fire. A fire alarm system may not provide timely or adequate warning, or simply may not function, for a variety of reasons:

**Smoke detectors** may not sense fire where smoke cannot reach the detectors such as in chimneys, in or behind walls, on roofs, or on the other side of closed doors. Smoke detectors also may not sense a fire on another level or floor of a building. A second-floor detector, for example, may not sense a first-floor or basement fire.

**Particles of combustion or "smoke"** from a developing fire may not reach the sensing chambers of smoke detectors because:

- Barriers such as closed or partially closed doors, walls, chimneys, even wet or humid areas may inhibit particle or smoke flow.
- Smoke particles may become "cold," stratify, and not reach the ceiling or upper walls where detectors are located.
- Smoke particles may be blown away from detectors by air outlets, such as air conditioning vents.
- Smoke particles may be drawn into air returns before reaching the detector.

The amount of "smoke" present may be insufficient to alarm smoke detectors. Smoke detectors are designed to alarm at various levels of smoke density. If such density levels are not created by a developing fire at the location of detectors, the detectors will not go into alarm.

Smoke detectors, even when working properly, have sensing limitations. Detectors that have photoelectronic sensing chambers tend to detect smoldering fires better than flaming fires, which have little visible smoke. Detectors that have ionizing-type sensing chambers tend to detect fast-flaming fires better than smoldering fires. Because fires develop in different ways and are often unpredictable in their growth, neither type of detector is necessarily best and a given type of detector may not provide adequate warning of a fire.

Smoke detectors cannot be expected to provide adequate warning of fires caused by arson, children playing with matches (especially in bedrooms), smoking in bed, and violent explosions (caused by escaping gas, improper storage of flammable materials, etc.).

**Heat detectors** do not sense particles of combustion and alarm only when heat on their sensors increases at a predetermined rate or reaches a predetermined level. Rate-of-rise heat detectors may be subject to reduced sensitivity over time. For this reason, the rate-of-rise feature of each detector should be tested at least once per year by a qualified fire protection specialist. Heat detectors are designed to protect property, not life.

**IMPORTANT! Smoke detectors** must be installed in the same room as the control panel and in rooms used by the system for the connection of alarm transmission wiring, communications, signaling, and/or power. If detectors are not so located, a developing fire may damage the alarm system, compromising its ability to report a fire.

**Audible warning devices such as bells, horns, strobes, speakers and displays** may not alert people if these devices are located on the other side of closed or partly open doors or are located on another floor of a building. Any warning device may fail to alert people with a disability or those who have recently consumed drugs, alcohol, or medication. Please note that:

- An emergency communication system may take priority over a fire alarm system in the event of a life safety emergency.
- Voice messaging systems must be designed to meet intelligibility requirements as defined by NFPA, local codes, and Authorities Having Jurisdiction (AHJ).
- Language and instructional requirements must be clearly disseminated on any local displays.
- Strobes can, under certain circumstances, cause seizures in people with conditions such as epilepsy.
- Studies have shown that certain people, even when they hear a fire alarm signal, do not respond to or comprehend the meaning of the signal. Audible devices, such as horns and bells, can have different tonal patterns and frequencies. It is the property owner's responsibility to conduct fire drills and other training exercises to make people aware of fire alarm signals and instruct them on the proper reaction to alarm signals.
- In rare instances, the sounding of a warning device can cause temporary or permanent hearing loss.

**A life safety system** will not operate without any electrical power. If AC power fails, the system will operate from standby batteries only for a specified time and only if the batteries have been properly maintained and replaced regularly.

**Equipment used in the system** may not be technically compatible with the control panel. It is essential to use only equipment listed for service with your control panel.

**Telephone lines** needed to transmit alarm signals from a premises to a central monitoring station may be out of service or temporarily disabled. For added protection against telephone line failure, backup radio transmission systems are recommended.

**The most common cause** of life safety system malfunction is inadequate maintenance. To keep the entire life safety system in excellent working order, ongoing maintenance is required per the manufacturer's recommendations, and UL and NFPA standards. At a minimum, the requirements of NFPA 72 shall be followed. Environments with large amounts of dust, dirt, or high air velocity require more frequent maintenance. A maintenance agreement should be arranged through the local manufacturer's representative. Maintenance should be scheduled as required by National and/or local fire codes and should be performed by authorized professional life safety system installers only. Adequate written records of all inspections should be kept.

Limit-D2-2016

# Installation Precautions

*Adherence to the following will aid in problem-free installation with long-term reliability:*

**WARNING - Several different sources of power can be connected to the fire alarm control panel.** Disconnect all sources of power before servicing. Control unit and associated equipment may be damaged by removing and/or inserting cards, modules, or interconnecting cables while the unit is energized. Do not attempt to install, service, or operate this unit until manuals are read and understood.

**CAUTION - System Re-acceptance Test after Software Changes:** To ensure proper system operation, this product must be tested in accordance with NFPA 72 after any programming operation or change in site-specific software. Re-acceptance testing is required after any change, addition or deletion of system components, or after any modification, repair or adjustment to system hardware or wiring. All components, circuits, system operations, or software functions known to be affected by a change must be 100% tested. In addition, to ensure that other operations are not inadvertently affected, at least 10% of initiating devices that are not directly affected by the change, up to a maximum of 50 devices, must also be tested and proper system operation verified.

**This system** meets NFPA requirements for operation at 0-49° C/32-120° F and at a relative humidity 93% ± 2% RH (non-condensing) at 32°C ± 2°C (90°F ± 3°F). However, the useful life of the system's standby batteries and the electronic components may be adversely affected by extreme temperature ranges and humidity. Therefore, it is recommended that this system and its peripherals be installed in an environment with a normal room temperature of 15-27° C/60-80° F.

**Verify that wire sizes are adequate** for all initiating and indicating device loops. Most devices cannot tolerate more than a 10% I.R. drop from the specified device voltage.

**Like all solid state electronic devices,** this system may operate erratically or can be damaged when subjected to lightning induced transients. Although no system is completely immune from lightning transients and interference, proper grounding will reduce susceptibility. Overhead or outside aerial wiring is not recommended, due to an increased susceptibility to nearby lightning strikes. Consult with the Technical Services Department if any problems are anticipated or encountered.

**Disconnect AC power and batteries** prior to removing or inserting circuit boards. Failure to do so can damage circuits.

**Remove all electronic assemblies** prior to any drilling, filing, reaming, or punching of the enclosure. When possible, make all cable entries from the sides or rear. Before making modifications, verify that they will not interfere with battery, transformer, or printed circuit board location.

**Do not tighten screw terminals** more than 9 in-lbs. Overtightening may damage threads, resulting in reduced terminal contact pressure and difficulty with screw terminal removal.

**This system contains static-sensitive components.**

Always ground yourself with a proper wrist strap before handling any circuits so that static charges are removed from the body. Use static suppressive packaging to protect electronic assemblies removed from the unit.

**Follow the instructions** in the installation, operating, and programming manuals. These instructions must be followed to avoid damage to the control panel and associated equipment. FACP operation and reliability depend upon proper installation.

Precau-D1-9-2005

## FCC Warning

**WARNING:** This equipment generates, uses, and can radiate radio frequency energy and if not installed and used in accordance with the instruction manual may cause interference to radio communications. It has been tested and found to comply with the limits for Class A computing devices pursuant to Subpart B of Part 15 of FCC Rules, which is designed to provide reasonable protection against such interference when devices are operating in a commercial environment. Operation of this equipment in a residential area is likely to cause interference, in which case the user will be required to correct the interference at his or her own expense.

## Canadian Requirements

This digital apparatus does not exceed the Class A limits for radiation noise emissions from digital apparatus set out in the Radio Interference Regulations of the Canadian Department of Communications.

Le present appareil numerique n'emet pas de bruits radioelectriques depassant les limites applicables aux appareils numeriques de la Classe A prescrites dan le Reglement sur le brouillage radioelectrique edicte par le ministere des Communications du Canada.

eVance™ is a trademark; and Acclimate®, FocalPoint®, Gamewell-FCI®, FAAST Fire Alarm Aspiration Sensing Technology®, Intelligent FAAST® SmartScan®, SWIFT®, Velociti®, and E3 Series® are registered trademarks of Honeywell International Inc. eVance™ is a trademark; and Silent Knight® and SWIFT® are registered trademarks of Honeywell International Inc. Microsoft® and Windows® are registered trademarks of the Microsoft Corporation Chrome™ and Google™ are trademarks of Google Inc.

©2016 by Honeywell International Inc. All rights reserved. Unauthorized use of this document is strictly prohibited.

## Software Downloads

In order to supply the latest features and functionality in fire alarm and life safety technology to our customers, we make frequent upgrades to the embedded software in our products. To ensure that you are installing and programming the latest features, we strongly recommend that you download the most current version of software for each product prior to commissioning any system. Contact Technical Support with any questions about software and the appropriate version for a specific application.

## Documentation Feedback

Your feedback helps us keep our documentation up-to-date and accurate. If you have any comments or suggestions about our online Help or printed manuals, you can email us.

Please include the following information:

- Product name and version number (if applicable)
- Printed manual or online Help
- Topic Title (for online Help)
- Page number (for printed manual)
- Brief description of content you think should be improved or corrected
- Your suggestion for how to correct/improve documentation

Send email messages to:

**FireSystems.TechPubs@honeywell.com**

Please note this email address is for documentation feedback only. If you have any technical issues, please contact Technical Services.

# Table of Contents

<b>Section 1: Introduction</b> .....	<b>8</b>
1.1: S3 Series Small Addressable Fire Alarm Control Panel .....	8
1.1.1: S3 Series Reference Documentation .....	8
1.2: Standards.....	9
1.3: Product Models Nomenclature .....	9
<b>Section 2: Installation Wiring</b> .....	<b>10</b>
2.1: Main Supply Circuit .....	10
2.1.1: FLPS-7 Main Supply Installation Wiring Diagram.....	10
2.1.2: FLPS-7 Installation Wiring Terminals .....	10
2.1.3: FLPS-7 Main Supply Circuit Specifications .....	10
2.1.4: Cabinet Enclosures for the FLPS-7 .....	10
2.2: SLP-E3 Main Circuit Installation Wiring Diagram .....	11
2.2.1: SLP-E3 Main Circuit Board Installation Wiring Terminals.....	11
2.2.2: SLP-E3 Rechargeable Battery Circuit Installation Wiring Diagram.....	13
2.2.3: SLP-E3 Rechargeable Battery Installation Wiring Terminals .....	13
2.2.4: SLP-E3 Rechargeable Battery Circuit Specifications .....	13
2.2.5: SLP-E3 Standby Battery Calculation Chart .....	14
2.3: Initiating Device Circuit .....	15
2.4: Notification Appliance Circuit (NAC) .....	15
2.4.1: Notification Appliance Circuit Wiring and Ratings .....	15
2.4.2: SLP-E3 Main Board Outputs.....	16
2.5: Supplementary Circuits .....	16
2.6: Signaling Line Circuit (SLC) (SLC-PM/SLC95-PM) .....	17
2.6.1: Signaling Line Circuit Wiring and Ratings .....	17
2.6.2: SLC-PM Installation Wiring Diagram- System Sensor .....	18
2.6.3: SLC-PM Installation Wiring Designations .....	18
2.6.4: SLC-PM Signaling Line Circuit Specifications .....	18
2.6.5: SLC95-PM Installation Wiring Diagram - Apollo .....	19
2.6.6: SLC95-PM Installation Wiring Designations .....	19
2.6.7: SLC95-PM Signaling Line Circuit Specifications .....	19
2.7: Remote Annunciator/Keypad Circuits.....	20
2.7.1: ANU-48 Remote Annunciator.....	20
2.7.2: ASM-16 Remote Annunciator.....	20
2.7.3: LCD-7100 Remote Annunciator .....	20
2.7.4: RAN-7100 Remote Annunciator .....	20
2.7.5: LCD-SLP Remote Annunciator.....	20
2.7.6: LCD-E3 Remote Annunciator .....	20
2.7.7: Remote Annunciator Installation Wiring Diagram .....	21
2.7.8: Remote Annunciator Installation Wiring Terminals .....	21
2.7.9: Remote Annunciator Specifications .....	21
2.7.10: LCD-SLP Installation Wiring Diagram.....	22
2.7.11: LCD-SLP Installation Wiring Terminals .....	22
2.7.12: LCD-SLP Keypad Circuit Specifications.....	23
2.7.13: Cabinet Enclosure for LCD-SLP .....	24
2.8: Reverse Polarity Communication Circuit .....	24
2.8.1: W1 Jumper Block (Polarity Reversal Configuration) .....	25
2.8.2: Reverse Polarity Circuit Specifications .....	25
2.9: Municipal Box Connection.....	25
2.9.1: W1 Jumper Block (Master Box/Releasing Solenoid Configuration) .....	26
2.10: Communication Circuits .....	26
2.10.1: S3 Series System Communication Circuits .....	26
2.10.2: RPT-E3-UTP Communication Circuit Specifications.....	26
2.10.3: RPT-E3-UTP Installation Wiring Diagram.....	26

2.10.4: RPT-E3-UTP Installation Wiring Terminals .....	27
2.10.5: RPT-E3-UTP Programming Address Switch Settings .....	28
2.10.6: FML-E3 Installation Wiring Diagram .....	29
2.10.7: FML-E3 Installation Wiring Terminals .....	29
2.10.8: FSL-E3 Installation Wiring Diagram .....	30
2.10.9: FSL-E3 Installation Wiring Terminals .....	30
2.10.10: DACT-E3 Communication Circuit .....	30
2.11: Power Output Circuits .....	31
2.11.1: Power Output Specifications .....	31
2.12: Releasing Device Circuit .....	32
2.12.1: Releasing Device Circuit Specifications .....	32
2.13: Relay Circuit, Open Collector and Other Similar Outputs .....	33
2.13.1: Relay Circuit Specifications .....	33
2.14: S3 Series System, SLP-BB Cabinet Assembly .....	34
2.14.1: SLP-BB Cabinet Installation .....	34
2.15: Separation of Circuits .....	35
2.15.1: S3 Series, SLP-BB Cabinet, Class 2 Power-Limited/Non Power-Limited Wiring Requirements .....	35
2.16: S3 Series System, B-Size Cabinet Assembly .....	37
2.16.1: S3 Series, B-Size Cabinet Installation .....	37
2.17: Separation of Circuits .....	38
2.17.1: S3 Series, B-Size Cabinet, Class 2 Power-Limited/Non Power-Limited Wiring Requirements .....	38
2.18: E3 Series, Cabinet A2 Assembly .....	40
2.18.1: E3 Series, Cabinet A2 Installation .....	40
2.19: E3BB-FLUSH-LCD Cabinet A2 Assembly .....	41
2.19.1: E3BB-FLUSH-LCD Cabinet A2 Installation .....	41
2.20: S3 Series System Configuration .....	43
<b>Section 3: Operation .....</b>	<b>44</b>
3.1: LCD-SLP Operation .....	44
3.1.1: LCD-SLP Panel Display Operation .....	44
3.1.2: LCD-SLP LED Indicators/Annunciators .....	44
3.1.3: LCD-SLP Audible/Visual Condition Indications .....	44
3.1.4: LCD-SLP Switches .....	45
3.2: S3 Series System Operation .....	45
3.3: Operating Instructions .....	45
<b>Section 4: Functionality .....</b>	<b>46</b>
4.1: SLP Main Board Features .....	46
4.1.1: Default Display Priority .....	48
4.1.2: Expected Operations Conditions .....	49
<b>Section 5: Programming Options .....</b>	<b>50</b>
5.1: uIP Code License .....	50
5.2: Programming Menu Selections .....	51
5.2.1: MAIN LCD-SLP Menu Selections .....	51
5.2.2: WALK / DRILL Menu Selection .....	51
5.2.3: I/O Menu Selection .....	51
5.2.4: CLOCK Menu Selection .....	51
5.2.5: MISC Menu Selection .....	52
5.2.6: LOG Menu Selection .....	52
5.2.7: INFO Menu Selection .....	52
<b>Section 6: Testing/Maintenance .....</b>	<b>53</b>
<b>Section 7: Compatibilities .....</b>	<b>54</b>
<b>Section 8: System Configuration .....</b>	<b>55</b>
8.1: S3 Series System Listed Service Type Applications .....	55
8.2: S3 Series System Configuration .....	55

8.3: S3 Series Module System Configurations .....56

**Section 9: System Power/Size ..... 57**

**Index..... 58**

# Section 1: Introduction

## 1.1 S3 Series Small Addressable Fire Alarm Control Panel

This Underwriter’s Laboratory Listing Document describes the design and operation of the principal components of the S3 Series (Small Addressable Fire Alarm Control Panel). The S3 Series is a Small Analog-Addressable Fire Alarm Control Panel (FACP) that may be used in standalone or networked configurations.

The S3 Series may be used as a standalone Fire Alarm Control Panel, providing the following features:

- One or two Signaling Line Circuits (SLCs) supporting System Sensor® Velociti®, System Sensor CLIP, or Apollo XP-95 protocols.
- Four Class B Notification Appliance Circuits (NACs), which may be paired to provide two Class A NACs.

The S3 Series provides an optional network interface board that allows the networked operation of multiple S3 Series and E3 Series® units.

- The network interface allows seamless integration with the Gamewell-FCI, S3 Series nodes and E3 Series nodes, including the ILI-E3 Series (Intelligent Loop Interface-E3), ILI95-E3 Series (Intelligent Loop Interface-95-E3), ANX (Addressable Node Expander), INI-VG Series (Intelligent Network Interface-Voice Gateway), and NGA (Network Graphic Annunciator).

### 1.1.1 S3 Series Reference Documentation

Table 1.1.1.1 lists the UL-Controlled documentation assigned to the S3 Series Project. If you require detailed installation instructions on cabinetry, wiring and specifications, you can download the following UL-Controlled documents from the ESD site on the Gamewell-FCI Website ([gamewell-fci.com](http://gamewell-fci.com)).

Part Number	Title
<b>ULLDs</b>	
LS10080-051GF-E	E3 Series Fire System UL Listing Document
<b>Manuals</b>	
9000-0575	E3 Series Broadband Installation/Operation Manual
9000-0577	E3 Series Classic Installation/Operation Manual
<b>Installation Instructions</b>	
9000-0491	LCD-7100 (Remote Serial Annunciator) Installation Instructions
9000-0550	ASM-16 (Addressable Switch Module) Installation Instructions
9000-0564	ANU-48 (Remote LED Driver Annunciator) Installation Instructions
9000-0568	NGA (Network Graphic Annunciator) Installation Instructions
9000-0569	ILI-S-E3 (Intelligent Loop Interface - Expansion Board) Installation Instructions
9000-0579	ILI-MB-E3 (Intelligent Loop Interface - Main Board) Installation Instructions
9000-0580	RPT-E3-UTP (Repeater-E3 Unshielded Twisted-Pair) Installation Instructions
9000-0581	DACT-E3 (Digital Alarm Communicator Transmitter) Installation Instructions
9000-0582	LCD-E3 (Liquid Crystal Display-E3) Installation Instructions
9001-0017	ILI95-MB-E3 (Intelligent Loop Interface-95 - Main Board) Installation Instructions
9001-0018	ILI95-S-E3 (Intelligent Loop Interface-95 - Expansion Board) Installation Instructions
9001-0064	ANX (Addressable Node Expander) Installation Instructions
9001-0066	RAN-7100 (Remote Alphanumeric Annunciator) Installation Instructions
LS10044-000GF-E	SLC-PM/SLC95-PM (Signaling Line Circuit-Personality Module) Installation Instructions
LS10045-000GF-E	LCD-SLP (Liquid Crystal Display-Smart Loop Panel) Installation Instructions
LS10046-000GF-E	FML-E3/FSL-E3 (Fiber-Optic Multi-Mode/Fiber-Optic Single-Mode) Installation Instructions
LS10058-000GF-E	FLPS-7 (Power Supply) Installation Instructions
LS10082-000GF-E	E3 Series Cabinets B, C, D, Retrofit, DR-C4/DR-D4 and EQ Installation Instructions
LS10083-000GF-E	E3 Series, Remote Annunciator Display and Retrofit Cabinets Installation Instructions
<b>Addendum</b>	
9000-0427-L8	Compatibility Addendum to Gamewell-FCI I/O Manuals UL File S1869 Vol. 8C
<b>Frame-Post</b>	
LS10056-000GF-E	S3 Series (Small Addressable Fire Alarm Control Panel System), Operating Instructions
<b>Label</b>	
50113616-001	S3 Series Door Label

**Table 1.1.1.1 S3 Series Reference Documents**

#### 1.1.1.1 Programming Documentation

This product uses the CAMWorks™ Software Program. Installers must be Gamewell-FCI Factory Certified to program this product. For additional information on this product, contact the Gamewell-FCI Customer Support to schedule the Factory Certified Training.



## 1.2 Standards

The S3 Series System complies with the following Standards:

### ■ Underwriters Laboratories Standards

The S3 Series System is suitable for the following signaling services that comply with the Underwriters Laboratories Standards:

- UL Standard 864 9th Edition:
  - Automatic Fire Detector Alarm
  - Manual Fire Alarm
  - Waterflow Alarm
  - Supervisory
  - Releasing Device Service
  - Automatic Smoke Alarm, non-coded and master coded operation

### ■ NFPA Standards

When the S3 Series System is configured and installed under the supervision of a Gamewell-FCI Factory Trained and Certified Distributor, the S3 Series System complies with the requirements of the following National Fire Protection Association (NFPA) Standards:

- NFPA 13 - Standard for Installation of Sprinkler Systems
- NFPA 16 - Standard for Foam-Water Sprinkler and Foam-Water Spray Systems
- NFPA 72 - National Fire Alarm Code:
  - Central Station Fire Alarm Systems
  - Auxiliary Fire Alarm Systems
  - Proprietary Fire Alarm Systems
  - Local Fire Alarm Systems
  - Remote Station Fire Alarm Systems



#### **NOTE: Positive Alarm Sequence Standard:**

UL 864 requires that PAS (Positive Alarm Sequence) be used only for alarm signals from automatic alarm devices such as smoke detectors.

To provide the PAS Bypass function, an input device (such as a Monitor Module or an ASM switch) must be provided and programmed for this purpose, using the Configuration Programming Tool called CAMWorks.

## 1.3 Product Models Nomenclature

Table 1.3.1 lists the nomenclature of the models included in each of the product line series that appear in this Manual. To determine which models are associated with the particular series that is mentioned in this Manual, refer to Table 1.3.1.

S3 Series Nomenclature				
SLP-E3	SLC-PM	SLC95-PM	FLPS-7	LCD-SLP
E3 Series®				
E3 Control Panel	ANX	NGA	RPT-E3-UTP	INX
E3 Broadband	ANX-SR	ILI-MB-E3	DACT-E3	INCC
E3 Classic	ANX-MR-FO	ILI-S-E3	IPDACT-2	INCC-MIC
PM-9	ANX-MR-UTP	ILI95-MB-E3	FPT-Works-WS	INCC-TEL
PM-9G	ANU-48	ILI95-S-E3	FPT-Mobile	E3 LOC
LCD-E3	ASM-16	Fire Fighter's Handset	FPT-GATE-3	E3 LOC-TEL
AM-50 Series			AA Series	
AM-50-25	AM-50-70		AA-100	AA-120
ILI-E3 Series			ILI95-E3 Series	
ILI-MB-E3	ILI-S-E3		ILI95-MB-E3	ILI95-S-E3
INI-VG Series				
INI-VGC	INI-VGE	INI-VGX		
MS-7 Series				
MS-7AF/ASF	MS-7	MS-7LOB	MS-7LR	MS-7LRA
MS-7A				
Apollo Series				
MS-95/MS-95T	PID-95/PID-95P	BCE-95	RCE-95	SCE-95
CZI-95				

**Table 1.3.1 Product Models Nomenclature**

## Section 2: Installation Wiring

This product is intended to be installed in accordance with local, regional and National standards. The S3 Series System (Small Addressable Fire Alarm Control Panel) comprises the following modules.

- | Required Modules  | Optional Modules  |
|---|---|
| <ul style="list-style-type: none"> <li>• SLP-E3 (Smart Loop Panel-Main Board)</li> <li>• SLC-PM or SLC95-PM (Signaling Loop Circuit Driver Module for System Sensor or Apollo Loop Devices)</li> <li>• LCD-SLP (Lead Crystal Display-Smart Loop Panel)</li> </ul> | <ul style="list-style-type: none"> <li>• LCD-E3, LCD-7100/RAN-7100 (Remote Display Modules)</li> <li>• DACT-E3 (Digital Alarm Communicator Transmitter)</li> <li>• ASM-16/ANU-48 (Switch LED Modules)</li> <li>• RPT-E3-UTP (Repeater Module)                             <ul style="list-style-type: none"> <li>– FML-E3 (Fiber-Optic Multi-Mode)</li> <li>– FSL-E3 (Fiber-Optic Single-Mode)</li> </ul> </li> </ul> |
| <ul style="list-style-type: none"> <li>• FLPS-7 (7 Amp Power Supply)</li> </ul>   |   |

### 2.1 Main Supply Circuit

The FLPS-7 is the main supply circuit for the S3 Series System.

#### 2.1.1 FLPS-7 Main Supply Installation Wiring Diagram

Figure 2.1.1.1 illustrates the FLPS-7 main supply circuit board diagram.

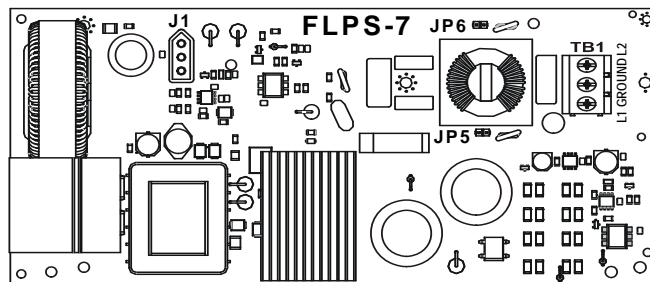

Figure 2.1.1.1 FLPS-7 Main Supply Circuit Board

#### 2.1.2 FLPS-7 Installation Wiring Terminals

Table 2.1.2.1 lists the FLPS-7 power supply installation wiring terminals.

Designation	Description	Designation	Description
L1	AC Power - Hot	J1	Power output connector
EARTH	Earth Ground	JP5	Factory set to 120 VAC
L2	AC Power - Neutral	JP6	Factory set to 120 VAC

Table 2.1.2.1 FLPS-7 Installation Wiring Terminals

#### 2.1.3 FLPS-7 Main Supply Circuit Specifications

The FLPS-7 is the main supply circuit for the S3 Series panel. Table 2.1.3.1 lists the FLPS-7 specifications.

Requirements	FLPS-7 Specifications
Circuit Supervision:	Supervised
Nominal Voltage, Frequency:	120 V AC, 60 Hz, Max. 2.75 Amps 240 V AC, 50/60 Hz, Max. 1.4 Amps
Max.current or power supply to be used:	FLPS-7, 7 amperes power supply, 7 A 24 VDC
Terminal for the connection of a grounded conductor:	See Figure 2.1.1.1.
Operating Temperature:	32° to 120° F (0° to 49° C)
Operating Humidity:	0 to 93%, non-condensing at 90° F (30° C)
The maximum time during which the standby operating source maintains the minimum operating voltage (85 percent of rated voltage). This is required for releasing devices under continuous load that can't maintain 85 percent of the rated operating voltage to the releasing devices for 60 seconds after energizing.	N/A
Type of device (automatic, manual, waterflow, sprinkler supervisory, watchman supervisory, etc.).	Refer to Section 1.3 (Product Models Nomenclature), Table 1.3.1 (Product Models Nomenclature).

Table 2.1.3.1 FLPS-7 Main Supply Circuit Specifications

#### 2.1.4 Cabinet Enclosures for the FLPS-7

Table 2.1.4.1 lists the cabinet enclosure you can use to install the SLP main board.

Cabinet	Part Numbers	Dimensions
SLP-BB cabinet (also called the B-Slim cabinet)	SLP-BB	14.1/2" W x 20 1/8" H x 4 1/2" D
S3 Series, Cabinet B-Size	S3BB-BB/RB	19.38" W x 19.38" H x 4.50" D

Table 2.1.4.1 FLPS-7 Main Board Cabinet

## 2.2 SLP-E3 Main Circuit Installation Wiring Diagram

The S3 Series System uses the SLP-E3 main board as the main circuit board. Figure 2.2.1 shows the SLP-E3 main circuit board sub-assembly.

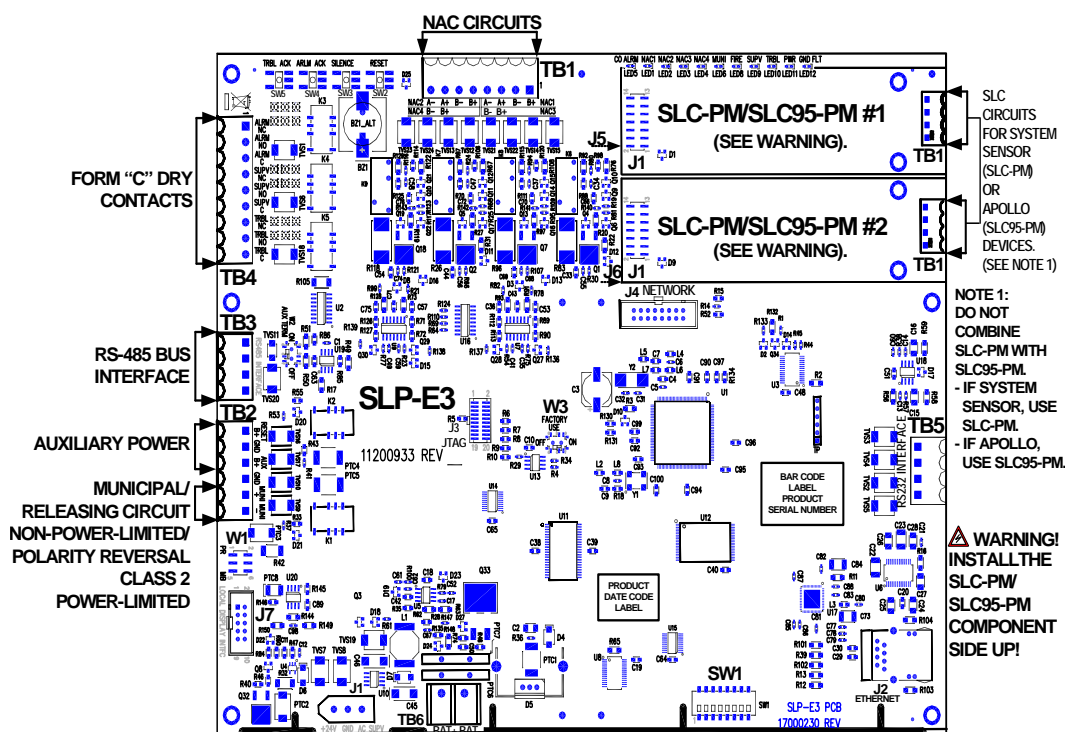

Figure 2.2.1 SLP-E3 Main Circuit Board

### 2.2.1 SLP-E3 Main Circuit Board Installation Wiring Terminals

Table 2.2.1.1 lists the SLP-E3 main board installation wiring terminals.

Designation	Description	Comments
TB1-1	NAC 1 B+	Notification Appliance Circuit 1, B+
TB1-2	NAC 1 B-	Notification Appliance Circuit 1, B-
TB1-3	NAC 1 A+/NAC 3 B+	Notification Appliance Circuit 1, Class A+ RETURN or Notification Appliance Circuit 3 B+
TB1-4	NAC 1 A-/NAC 3 B-	Notification Appliance Circuit 1, Class A- RETURN or Notification Appliance Circuit 3 B-
TB1-5	NAC 2 B+	Notification Appliance Circuit 2 B+
TB1-6	NAC 2 B-	Notification Appliance Circuit 2 B-
TB1-7	NAC 2 A+/NAC 4 B+	Notification Appliance Circuit 2 Class A RETURN A+ or Notification Appliance Circuit 4 B+
TB1-8	NAC 2 A-/NAC 4 B-	Notification Appliance Circuit 2 Class A RETURN A- or Notification Appliance Circuit 4 B-
TB2-1	RESET B+	Resettable 24 VDC Auxiliary Power
TB2-2	GND	Resettable or Non-Resettable Power Common Negative
TB2-3	AUX B+	Non-resettable 24 VDC Auxiliary Power
TB2-4		Make no connection
TB2-5	MUNI +	Positive Output to Local Energy City Box, Remote Station or Releasing Solenoid (See Note 1 and Jumper W1).
TB2-6	MUNI -	Negative Output to Local Energy City Box, Remote Station or Releasing Solenoid (See Note 1 and Jumper W1).
TB3-1	RS-485 Interface	AUX RS-485 COMM A Output
TB3-2	RS-485 Interface	AUX RS-485 COMM B Output
TB3-3	Ground	Earth Ground
TB3-4	Reserved	Spare (N/C)
TB4-1	ALRM NC	Alarm relay contact normally CLOSED N/C
TB4-2	ALRM NO	Alarm relay contact normally OPEN N/O
TB4-3	ALRM C	Alarm relay contact common
TB4-4	SUPV NC	Supervisory relay contact normally CLOSED N/C

Table 2.2.1.1 SLP-E3 Main Circuit Board Installation Wiring Terminals

Designation	Description	Comments
TB4-5	SUPV NO	Supervisory relay contact normally OPEN N/O
TB4-6	SUPV C	Supervisory relay contact common
TB4-7	TRBL NC	Trouble relay contact normally CLOSED N/C
TB4-8	TRBL NO	Trouble relay contact normally OPEN N/C
TB4-9	TRBL C	Trouble relay contact common
TB5-1	RS-232 GND	For Programming, GND connects to red lead on the download cable P/N 75267. For Printer Port, GND connects to printer DB-9, PIN-5.
TB5-2	RS-232 TxD	For Programming, TxD connects to black lead on the download cable P/N 75267. For Printer Port, TxD connects to printer DB-9, PIN-2.
TB5-3	RS-232 Supervision	Optional printer supervision. For Printer Port, SUPV connects to printer DB-9, PIN-4.
TB5-4	RS-232 RxD	For Programming, RxD connects to green lead on the download cable P/N 75267. For Printer Port, RxD connects to printer DB-9, PIN-3.
TB6-1	BAT +	Positive power for battery connection
TB6-2	BAT -	Negative power for battery connection
J1	AC SUPV / + 24	Power supply input connection
J2	ETHERNET	RJ45 10/100 Ethernet connection for configuration downloading and /or FocalPoint connection (See Note 3)
J4	NETWORK	Connects to J10 of the RPT-E3-UTP
J5	SLC-PM Loop 1	SLC-PM Card connection for Loop 1
J6	SLC95-PM Loop 2	SLC95-PM Card connection for Loop 2
J7	LOCAL DISPLAY	Local Display (LCD-SLP) connection. Connects to J5 of the LCD-SLP.
SW1-1	SLC 1 Disconnect	SLC1 disconnect (ON to disconnect, normally OFF) (See Note 4)
SW1-2	SLC 2 Disconnect	SLC2 disconnect (ON to disconnect, normally OFF) (See Note 4)
SW1-3	NAC 1-NAC 4 Disconnect	NAC1-NAC4 disconnect (ON to disconnect, normally OFF) (See Note 4)
SW1-4	Buzzer Disable	The main SLP-E3 Buzzer disable (ON to suppress local buzzer, normally OFF on the SLP-E3) (See Note 4)
SW1-5	RS-232 BAUD Rate Configure	RS-232 BAUD rate override (ON to force 115,200bps, OFF for configured BAUD rate)
SW1-6	For Future Use	Reserved
SW1-7	For Future Use	Reserved
SW1-8	For Future Use	Reserved
SW2	RESET	System Reset button
SW3	SILENCE	System Silence button
SW4	ARLM ACK	System Alarm Acknowledge button
SW5	TRBL ACK	System Trouble Acknowledge button
W1	MB/PR	"MB" = For Masterbox/Releasing Solenoid "PR" = For Polarity Reversal (See Note 1)
W2	AUX TERM	OFF (Normal RS485 operation) ON (RS485 Termination)
<b>NOTES</b>		
<b>NOTE 1:</b> When you use the output for Releasing, verify Jumper W1 and configure within CAMWorks. Refer to Releasing in the General Settings Section for proper operation.		
<b>NOTE 2:</b> The RS-232 printer port connection cannot exceed 20 ft.; it must be in conduit and in the same room as the panel. The PRN-7 Printer is a dot-matrix printer. It is shipped with a DB-9 Adapter Kit that provides the necessary hardware and cables for installation. For additional information on the PRN-7 Printer, refer to the Manufacturer's Installation Guide.		
<b>NOTE 3:</b> When the Ethernet port is connected to FocalPoint, it cannot exceed 20 ft.; it must be in conduit and in the same room as the panel.		
<b>NOTE 4:</b> For Service Use Only.		

Table 2.2.1.1 SLP-E3 Main Circuit Board Installation Wiring Terminals (Continued)

## 2.2.2 SLP-E3 Rechargeable Battery Circuit Installation Wiring Diagram

Figure 2.2.2.1 shows the SLP-E3 rechargeable battery installation wiring diagram.

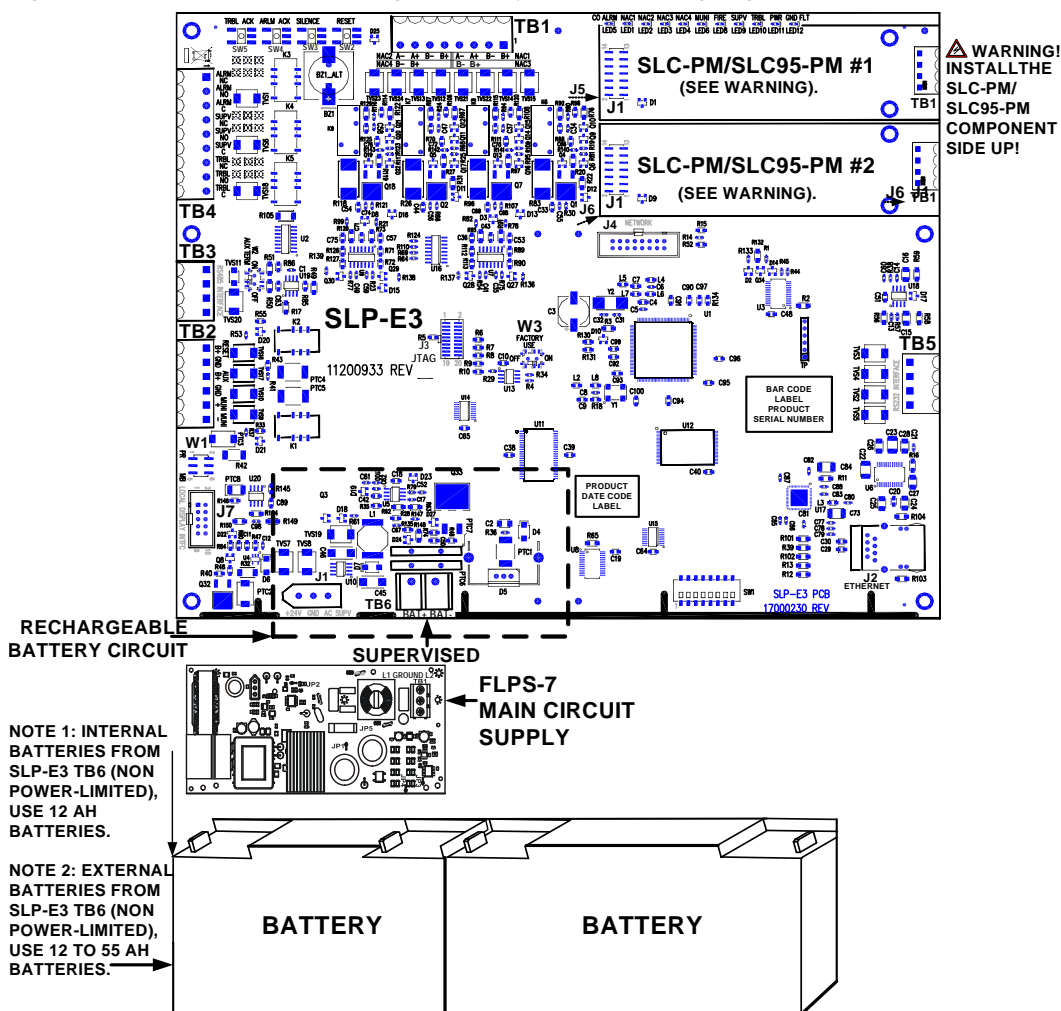

Figure 2.2.2.1 SLP-E3 Rechargeable Battery Installation Wiring Diagram

## 2.2.3 SLP-E3 Rechargeable Battery Installation Wiring Terminals

Table 2.2.3.1 lists the SLP-E3 rechargeable battery installation wiring terminals.

Designation	Description	Comments
TB6	BAT+/BAT-	Battery Connection

Table 2.2.3.1 SLP-E3 Rechargeable Battery Circuit Installation Wiring Terminals

## 2.2.4 SLP-E3 Rechargeable Battery Circuit Specifications

The S3 Series (Small Addressable FACP) provides the SLP-E3 rechargeable battery circuit. Table 2.2.4.1 lists the SLP-E3 rechargeable battery circuit specifications.

Requirements	SLP-E3 Specifications
Circuit Supervision	Supervised for Short, Open, Ground Fault, Charger Fail
Nominal Voltage	+24 VDC
Supervisory Current	0.100 amps
Alarm Current	0.180 amps
Suitable Battery Type	Sealed Lead Acid
Battery Charging Current	1 A
Minimum Battery Capacity	7 A/H (minimum)
Maximum Battery Capacity	55 A/H
Maximum Standby Duration	4, 24, 60, 90 Hours (See Note 1)
Maximum Alarm Operation Following Standby	5, 15, 30, 60 minutes at Full Load (See Note 2)

Table 2.2.4.1 SLP-E3 Main Circuit Specifications

<b>NOTES</b>
<p><b>NOTE 1:</b> Four hour standby permitted for installations with automatic backup generators. 24, 60 hours as required by code. Use Table 2.2.5.1 to obtain the correct sized battery capacity required.</p>
<p><b>NOTE 2:</b> 5, 15, 30 or 60 minute Alarm duration as required by code. Use Table 2.2.5.1 to obtain the correct sized battery capacity required.</p>

**Table 2.2.4.1 SLP-E3 Main Circuit Specifications**

### 2.2.5 SLP-E3 Standby Battery Calculation Chart

Table 2.2.5.1 lists the SLP-E3 Standby Battery Calculations.

Qty	Module	Description	Supv. Current	Alarm Current	Total Supv. Current	Total Alarm Current
	SLP-E3	Smart Loop Panel-Main Board	0.100 A	0.180 A		
		Resettable Auxiliary Power, max. 1.75 A				
		Non-Resettable Auxiliary Power, max. 1.75 A				
		Municipal, max. 0.75 A				
		Notification Appliances (See Note 6)				
	SLC-PM	Signaling Line Circuit - Personality Board	0.014 A	0.014 A		
		Addressable Sensors & Modules (See Note 6)				
		Signaling Line Circuits (SLCs) (See Note 6)				
	SLC95-PM	Signaling Line Circuit 95 - Personality Board	0.016 A	0.016 A		
		Addressable Sensors & Modules (See Note 6)				
		Signaling Line Circuits (SLCs) (See Note 6)				
	LCD-SLP	LCD Display/Switch Control (See Note 3)	0.030 A	0.065 A		
	LCD-E3	LCD Display/Switch Control	0.024 A	0.028 A		
	ASM-16	Annunciator Switch Module	0.011 amp (with no LEDs lit)	0.011 amp (See Note 4)		
	ANU-48	Remote LED Driver Assembly	0.011 amp	0.011 amp (See Note 5)		
	LCD-7100/ RAN-7100	Remote Display Module	0.12 A	0.23 A		
	DACT-E3	Digital Dialer Communication Transmitter	0.018 A	0.018 A		
	RPT-E3-UTP	ARCNet Repeater	0.016 A	0.017 A		
	FML-E3	Fiber-Optic Multi-Mode Board	0.053 A	0.053 A		
	FSL-E3	Fiber-Optic Single Mode Board	0.079 A	0.079 A		
<b>User Calculation Totals</b>						
A	Total Supervisory Current (See Note 6)					
B	Enter number of standby hours required (See Note 1)					
C	Multiply Line A times hours in Line B—enter					
D	Total alarm current from above					
E	Enter alarm sounding period in hours.					
F	Multiply Line D times Line E—enter					
G	Total of Lines C & F—enter					
H	Multiply Line G by 1.2 --- enter (Total ampere/hours required) (See Note 2)					
<b>NOTES</b>						
<p><b>NOTE 1:</b> 24 hours for NFPA 72 protected premises or Central Station signaling, or Auxiliary, or Remote Supervising Station Fire Alarm Systems.</p>						
<p><b>NOTE 2:</b> Use the next size battery with a capacity greater than required. (Use only Gamewell-FCI Models: B-17R, B-55R, BAT-12120, BAT-12260, or BAT-12550 batteries). The maximum standby current is 0.560 A for 60 hours when using 55 A/H batteries. To comply with FM standards, use 0.247 A for 90 hours when using 55 A/H batteries. The system batteries must be replaced as a set.</p>						

**Table 2.2.5.1 SLP-E3 Standby Battery Calculation Chart**

NOTES (Continued)
<b>NOTE 3:</b> Normal operating current. During a power failure, current drops to 0.045 amp since backlight is extinguished.
<b>NOTE 4:</b> Add .003 amp for any LED to be lit for any condition when powered internally.
<b>NOTE 5:</b> Add .003 amp for any LED to be lit for any condition when powered internally. When powered externally, a max. output current of .050/point is available for a maximum total output of 2.4 amp/ANU-48.
<b>NOTE 6:</b> For additional information on the System Sensor and Apollo device types and other Manufacturers' device currents, refer to the <i>Compatibility Addendum for Gamewell-FCI Manuals, P/N: 9000-0427-L8-L8</i> .

**Table 2.2.5.1 SLP-E3 Standby Battery Calculation Chart (Continued)**

## 2.3 Initiating Device Circuit

For information on the initiating device circuit, refer to Section 2.6, "Signaling Line Circuit (SLC) (SLC-PM/SLC95-PM)".

## 2.4 Notification Appliance Circuit (NAC)

The following subsections list the UL requirements for NACs and the corresponding E3 Series specifications.

### 2.4.1 Notification Appliance Circuit Wiring and Ratings

The S3 Series panel provides two Class A, Style Z or four Class B, Style Y notification appliance circuits. The NAC Sync is optionally available for horn and strobe devices for all NAC circuits using the configuration options in CAMWorks. For more information, refer to the CAMWorks Online Help.

See Figure 2.4.1.1 for wiring information.

For a list of the approved compatible devices, refer to the *Compatibility Addendum to Gamewell-FCI Manuals, P/N: 9000-0427-L8-L8*.

Class B, Style Y		Class A, Style Z	
NAC 1	TB1-1 (B+)	NAC 1	TB1-1 (B+)
NAC 1	TB1-2 (B-)	NAC 1	TB1-3 (A+)
NAC 2	TB1-5 (B+)	NAC 1	TB1-2 (B-)
NAC 2	TB1-6 (B-)	NAC 1	TB1-4 (A-)
NAC 3	TB1-3 (B+)	NAC 2	TB1-5 (B+)
NAC 3	TB1-4 (B-)	NAC 2	TB1-7 (A+)
NAC 4	TB1-7 (B+)	NAC 2	TB1-6 (B-)
NAC 4	TB1-8 (B-)	NAC 2	TB1-8 (A-)

**Note:** Polarity markings indicate the polarity of the circuit in alarm condition. Use UL Listed End-of-Line Resistor EOL-N (33K), P/N: 4700-0484 for Class B, Style Y wiring.

#### Circuit Ratings:

24 VDC (Nominal)

Max. Alarm Load: 2.0 A/circuit Special Applications

Ground Fault Test Impedance: Zero Ohms

Supervised, Class 2 Power-Limited, 18 AWG minimum

**NOTE:** NAC Synchronization: per circuit.

#### Coded Notification:

On board NAC circuits can provide Coded Notification.

Zone Coding allows an FACP to produce a distinct coded pattern on its NAC outputs, based upon the particular input device or cross zone that caused the alarm condition.

The S3 supports up to 63 different codes, each of which may be configured for any pattern of two, three, or four digits. The digits may range from 1 to 14 pulses. Unique codes can be associated with individual input devices and cross zones in the CAMWorks Configuration Program. Alternatively, multiple inputs may be assigned to run the same code (up to a limit of 63 different codes).

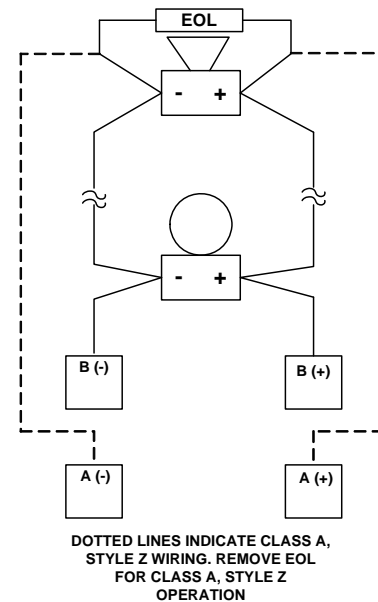

**Figure 2.4.1.1 Notification Appliance Circuits**

Table 2.4.1.1 lists the Notification Appliance Circuit specifications.

Requirements	NACs Specifications
Circuit Supervision:	Supervised
Power-Limited:	Class 2 Power-Limited
Type of signaling devices and connection, if polarized, indicate proper wiring with plus or minus (+-) symbols, or equivalent for proper field connection.	Refer to Figure 2.4.1.1.
Max. current, rated voltage and frequency:	2.0 amps per circuit not to exceed a total of 6.5 amps on all circuits.
Identifying circuit with rating designation. Identify appliances/devices by manufacturer's name, model and max. # of devices/circuit.	Refer to the Compatibility Addendum to Gamewell-FCI Manuals, P/N: 9000-0427-L8-L8.
Max. RMS operating current for any single NAC appliance, where sync. NAC appliances not employed.	Refer to the Compatibility Addendum to Gamewell-FCI Manuals, P/N: 9000-0427-L8-L8.
Each NAC, identify if synchronized NAC appliance are permitted. If synchronized NAC appliances employed, specify max. # per circuit if # exceeds loading calculations.	2.0 amps/circuit
Full-wave rectified voltages identified:	Uses filtered DC voltages.
EOL Resistor Part Number or value:	6.2 K - 47 K, 1/4 W or higher, -or- 3.2 K - 6.2 K, 1/2W or higher, -or- 1.5 K - 3.2 K, 1W or higher.
Identified by Class or by Class/Style:	Two 24 VDC Class A, Style Z or four Class B, Style Y notification appliance circuits.
Impedance values for testing at which ground faults are annunciated.	Zero Ohms
For each NAC, identify if synchronized NAC appliances are permitted. If synchronized NAC appliances employed, specify max. # per circuit if # exceeds leading calculations.	Refer to the Compatibility Addendum for Gamewell-FCI Manuals, P/N: 9000-0427-L8-L8.
Notification Appliance Circuit (NAC), Addressable NAC circuits using AOM-2FS or MMO-6SF modules:	Refer to Section 2.6.1(Signaling Line Circuit Wiring and Ratings)

**Table 2.4.1.1 Notification Appliance Circuit Specifications**

## 2.4.2 SLP-E3 Main Board Outputs

The SLP-E3 provides output for a Local Energy City Master Box, Reversing Polarity Output for leased line connection Service. Table 2.4.2.1 lists the SLP-E3 main board outputs.

Ratings	Master Box (NPL)	Polarity Reversal (PL)	Releasing Service
Nominal Voltage	24 VDC	24 VDC	24 VDC
Supervisory Current:	.0018 amp	.012 amp	.0005 amp
Alarm Current:	.510 amp (max.)	.012 amp	.700 amp
Line Resistance	35 Ohms (max.)		2 Ohms (max.)
Trip Coil Resistance	14.5 Ohms (max.)		

**Table 2.4.2.1 SLP-E3 Main Board Outputs**

## 2.5 Supplementary Circuits

N/A



## 2.6 Signaling Line Circuit (SLC) (SLC-PM/SLC95-PM)

The SLP panel provides the option of either of the following Loop Cards:

- SLC-PM (Signaling Line Circuit-Personality Module)  
The SLC-PM is used with the System Sensor devices.
- SLC95-PM (Signaling Line Circuit 95-Personality Module)  
The SLC95-PM is used with the Apollo devices.



**WARNING: SLC-PM/SLC95-PM RESTRICTION:**  
**DO NOT COMBINE THE SLC-PM AND THE SLC95-PM ON THE SLP MAIN BOARD.**  
 - DETECTOR SPACING MUST MEET NFPA 72 REQUIREMENTS  
 - THE ALARM VERIFICATION FEATURE IS BLOCKED FROM BEING APPLIED TO DEVICES USED IN POINT AND GROUP CROSS ZONES BY CAMWORKS.

### 2.6.1 Signaling Line Circuit Wiring and Ratings

The SLP-E3 provides up to two 24 VDC Class A, Style 6, Style 7 or four Class B, Style 4 signaling line circuits. See Figure 2.6.1.1 for wiring information. Style 7 (Class X) wiring requires the use of an M500X Isolator Module (SLC-PM), or XP95-LI Line Isolator or XP95-LIB Line Isolator Base (SLC95-PM) on both sides of a device.

#### SLC-PM Wiring Instructions

SLC 1 Style 4 TB1-1 (+), TB1-2 (-) OUT  
 SLC 2 Style 4 TB1-1 (+), TB1-2 (-) OUT  
 SLC 1 Style 6 TB1-3 (+) OUT, TB1-4 (-) RETURN  
 SLC-2 Style 6 TB1-3 (+) OUT, TB1-4 (-) RETURN

#### SLC95-PM Wiring Instructions

SLC 1 Style 4 TB1-1 (+), TB1-2 (-) OUT  
 SLC 2 Style 4 TB1-1 (+), TB1-2 (-) OUT  
 SLC 1 Style 6 TB1-3 (+) OUT, TB1-4 (-) RETURN  
 SLC-2 Style 6 TB1-3 (+) OUT, TB1-4 (-) RETURN

(Polarity markings indicate the polarity that should be maintained throughout the circuit. Polarity connected to the circuit must be observed on all devices).

#### SLC-PM/SLC95-PM Circuit Ratings

24 VDC (nominal)

#### Currents:

SLC-PM	0.014 amp max. (Supervisory)
SLC-PM	0.014 amp max. (Alarm)
SLC95-PM	0.016 amp max. (Supervisory)
SLC95-PM	0.016 amp max. (Alarm)
	40 Ohms max. line impedance
	0.5 µf max. line capacitance

Ground fault test impedance: Zero Ohms

Wiring: 18 AWG minimum, twisted-pair, unshielded  
 Supervised, Class 2 Power-Limited

For additional information, refer to the Compatibility Addendum for Gamewell-FCI Manuals, P/N: 9000-0427-L8.

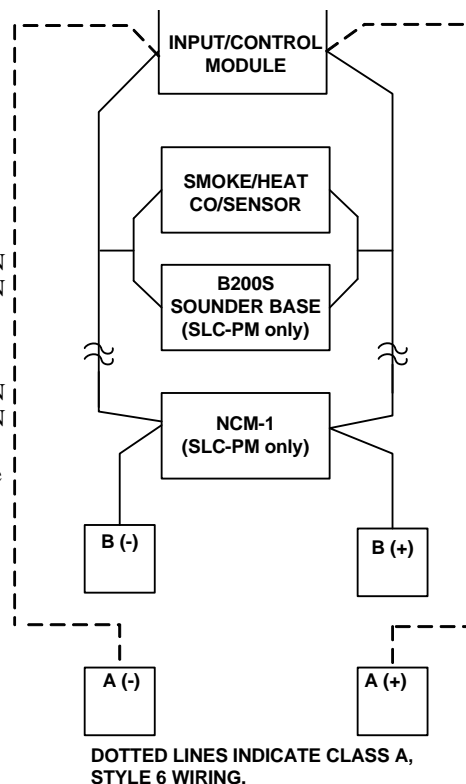

**Figure 2.6.1.1 Signaling Line Circuits**



#### NOTE: Drift Compensation:

The S3 Series contains a program that performs continuous testing of analog sensors, including Sensitivity Tests. This program will compensate all analog sensors for age and environmental conditions. If a problem occurs in a sensor, a “Failed Test”, “Dirty”, or “Very Dirty” indication for the specific device will appear on the System Display and will be recorded in the Event Log and the Serial Port.

#### Survivability for Addressable NAC Circuits Utilizing AOM-2SF or MMO-6SF Modules

Per the National Fire Alarm Code, NFPA 72, all circuits necessary for the operation of the notification appliances shall be protected until they enter the evacuation signaling zone that they serve. Any of the following methods shall be considered acceptable as meeting these requirements:

- A 2-hour rated cable or cable system.
- A 2-hour rated enclosure.
- Performance alternatives approved by Authority Having Jurisdiction (AHJ).

### 2.6.2 SLC-PM Installation Wiring Diagram- System Sensor

Figure 2.6.2.1 illustrates the SLC-PM circuit board diagram. For system assembly and installation wiring terminal designations, refer to the *SLC-PM/SLC95-PM Installation Instructions, P/N: LS10044-000GF-E*. You can download this document from the Gamewell-FCI Website ([www.gamewell-fci.com](http://www.gamewell-fci.com)).

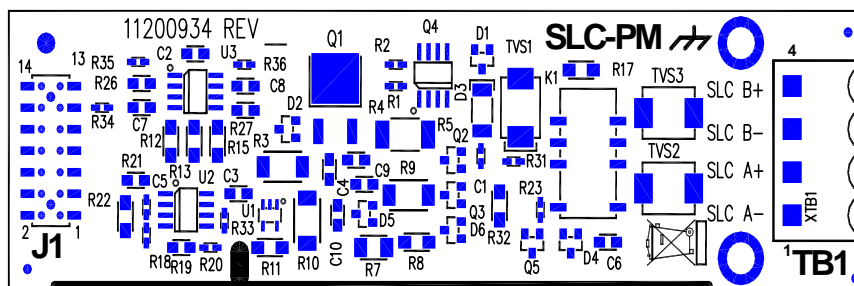

Figure 2.6.2.1 SLC-PM Circuit Board

### 2.6.3 SLC-PM Installation Wiring Designations

Table 2.6.3.1 lists the SLC-PM installation wiring designations.

Designation	Description	Comments
TB1-1	SLC A-	Style 6, Style 7 RETURN (See Note 1)
TB1-2	SLC A+	Style 6, Style 7 RETURN (See Note 1)
TB1-3	SLC B-	Style 4/6, Style 7 OUT (See Note 1)
TB1-4	SLC B+	Style 4/6, Style 7 OUT (See Note 1)
J1	SLC-PM Loop 1	Connects to J5 of the SLP-E3 (See Note 2)

**NOTE:** For Style 4, use Terminals B+ and B- only. For Style 6, use terminals B+ and B- and connect RETURN wiring to A+ and A-. For Style 7 (Class X), wire the same as Style 6 and use the M500X Isolator Modules per the recommendations as required.

**NOTE 2:** Mount the SLC-PM board component side up. Insert the connector pins extending from J5 on the SLP-E3 to the J1 connector underneath the SLC-PM board. (For additional information, refer to the Warning and the *SLC-PM/SLC95-PM Installation Instructions, P/N: LS10044-000GF-E*).

Table 2.6.3.1 SLC-PM Installation Wiring Designations



**WARNING: SLC-PM INSTALLATION TO SLP-E3 REQUIREMENT: INSTALL THE SLC-PM BOARD COMPONENT SIDE UP.**

### 2.6.4 SLC-PM Signaling Line Circuit Specifications

Table 2.6.4.1 lists the SLC-PM signaling line circuit specifications.

Requirements	SLC-PM Specifications
Circuit Supervision:	Supervised
Circuit Power-Limited:	Class 2 Power-Limited
Nominal Voltage, Frequency:	24 VDC (from FLPS-7 power supply)
Standby Current max. voltage, rated:	0.014 amp
Alarm Current:	0.014 amp
Identify the Manufacturer's Name, Model designation for appliances to be used on the circuit or reference the device compatibility section/document.	Refer to the Compatibility Addendum to Gamewell-FCI Manuals, P/N: 9000-0427-L8.
Max. Line Impedance:	40 Ohms and .5 µF line capacitance
Ground Fault Test Impedance:	Zero Ohms
Impedance values and ground faults are annunciated.	GND FAULT LED or LCD-SLP
Identified by class or by class/style:	One Class A, Style 6, Style 7 or Class B, Style 4 signaling line circuit.

Table 2.6.4.1 SLC-PM Signaling Line Circuit Specifications

### 2.6.5 SLC95-PM Installation Wiring Diagram - Apollo

Figure 2.6.5.1 shows the SLC95-PM circuit board diagram. For system assembly and installation wiring terminal designations, refer to the *SLC-PM/SLC95-PM Installation Instructions, P/N: LS10044-000GF-E*. You can download this document from the Gamewell-FCI Website ([www.gamewell-fci.com](http://www.gamewell-fci.com))

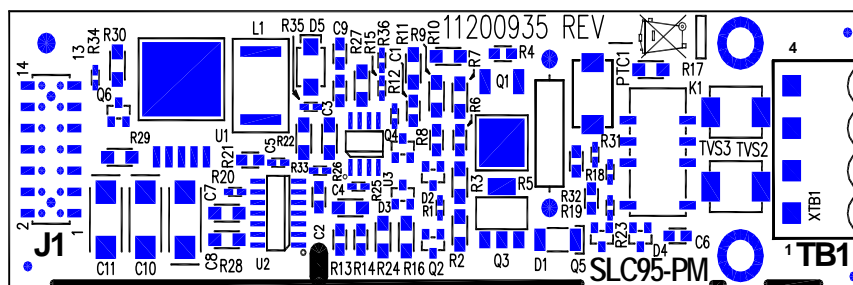

Figure 2.6.5.1 SLC95-PM Circuit Board

### 2.6.6 SLC95-PM Installation Wiring Designations

Table 2.6.6.1 lists the SLC95-PM installation terminal designations, descriptions and additional information.

Designation	Description	Comments
TB1-1	SLC A-	Style 6, Style 7 RETURN (See Note 1)
TB1-2	SLC A+	Style 6, Style 7 RETURN (See Note 1)
TB1-3	SLC B-	Style 4/6, Style 7 OUT (See Note 1)
TB1-4	SLC B+	Style 4/6, Style 7 OUT (See Note 1)
J1	SLC95-PM Loop 2	Connects to J6 connector pins of the SLP-E3. (See Note 2)

**NOTE 1:** For Style 4, use Terminals B+ and B- only. For Style 6, use terminals B+ and B- and connect RETURN wiring to A+ and A-. For Style 7 (Class X), wire the same as Style 6 and use the XP95-LI Line Isolator and XP95-LIB Isolator Base per the recommendations as required.

**NOTE 2:** Mount the SLC95-PM board component side up. Insert the connector pins extending from J6 on the SLP-E3 to the J1 connector underneath the SLC95-PM board. (For additional information, refer to the Warning and the *SLC-PM/SLC95-PM Installation Instructions, P/N: LS10044-000GF-E*).

Table 2.6.6.1 SLC95-PM Installation Wiring Designations



**WARNING: SLC95-PM INSTALLATION TO SLP-E3 REQUIREMENT: INSTALL THE SLC95-PM BOARD COMPONENT SIDE UP.**

### 2.6.7 SLC95-PM Signaling Line Circuit Specifications

Table 2.6.7.1 lists the SLC95-PM signaling line circuit specifications.

Requirements	SLC95-PM Specifications
Circuit Supervision:	Supervised
Circuit Power-Limited:	Class 2 Power-Limited
Nominal Voltage, Frequency:	24 VDC (from FLPS-7 power supply)
Standby Current max. voltage, rated:	0.016 amp
Alarm Current:	0.016 amp
Identify the Manufacturer's Name, Model designation for appliances to be used on the circuit or reference the device compatibility section/document.	Refer to the Compatibility Addendum to Gamewell-FCI Manuals, P/N: 9000-0427-L8.
Maximum Line Impedance:	40 Ohms and .5 $\mu$ F line capacitance
Ground Fault Test Impedance:	Zero Ohms
Impedance values and ground faults are annunciated.	GND FAULT LED or LCD-SLP
Identified by class or by class/style:	One Class A, Style 6, Style 7 or Class B, Style 4 signaling line circuits.

Table 2.6.7.1 SLC95-PM Signaling Line Circuit Specifications

## 2.7 Remote Annunciator/Keypad Circuits

In the S3 Series System, the SLP-E3 supports the following remote annunciators:

- ANU-48
- ASM-16
- LCD-7100
- RAN-7100
- LCD-SLP
- LCD-E3

### 2.7.1 ANU-48 Remote Annunciator

In the S3 Series System, you can use up to sixteen ANU-48 remote annunciators to remotely connect to the SLP-E3 panel. For information on the following, refer to the *ANU-48 Installation Instructions, Part Number: 9000-0564*.

- Cabinet Installation
- Wiring Installation
- Specifications

### 2.7.2 ASM-16 Remote Annunciator

In the S3 Series System, you can use up to sixteen ASM-16 remote annunciators to remotely connect to the SLP-E3 panel. For information on the following, refer to the *ASM-16 Installation Instructions, Part Number: 9000-0550*.

- Cabinet Installation
- Wiring Installation
- Specifications

### 2.7.3 LCD-7100 Remote Annunciator

In the S3 Series System, you can use up to five LCD-7100 remote annunciators to remotely connect to the SLP-E3 panel. For information on the following, refer to the *LCD-7100 Installation Instructions, Part Number: 9000-0491*.

- Cabinet Installation
- Wiring Installation
- Specifications

### 2.7.4 RAN-7100 Remote Annunciator

In the S3 Series System, you can use up to five RAN-7100 remote annunciators to remotely connect to the SLP-E3 panel. For information on the following, refer to the *RAN-7100 Installation Instructions, Part Number: 9001-0066*.

- Cabinet Installation
- Wiring Installation
- Specifications

### 2.7.5 LCD-SLP Remote Annunciator

In the S3 Series System, you can use up to fifteen LCD-SLP remote annunciators to remotely connect to the SLP-E3 panel. For information on the following, refer to the Section 2.7.10 thru Section 2.7.13 and the *LCD-SLP Installation Instructions, Part Number: LS10045-000GF-E*.

- Cabinet Installation
- Wiring Installation
- Specifications

### 2.7.6 LCD-E3 Remote Annunciator

In the S3 Series System, you can use up to six LCD-E3 remote annunciators to remotely connect to the SLP-E3 panel. For information on the following, refer to the *LCD-E3 Installation Instructions, Part Number: 9000-0582*.

- Cabinet Installation
- Wiring Installation
- Specifications

### 2.7.7 Remote Annunciator Installation Wiring Diagram

In the S3 Series System, the Liquid Crystal Display-Smart Loop Panel (LCD-SLP) is the Local Annunciator/Keypad Circuit for the SLP. Figure 2.7.7.1 illustrates the remote annunciators on the SLP main board panel.

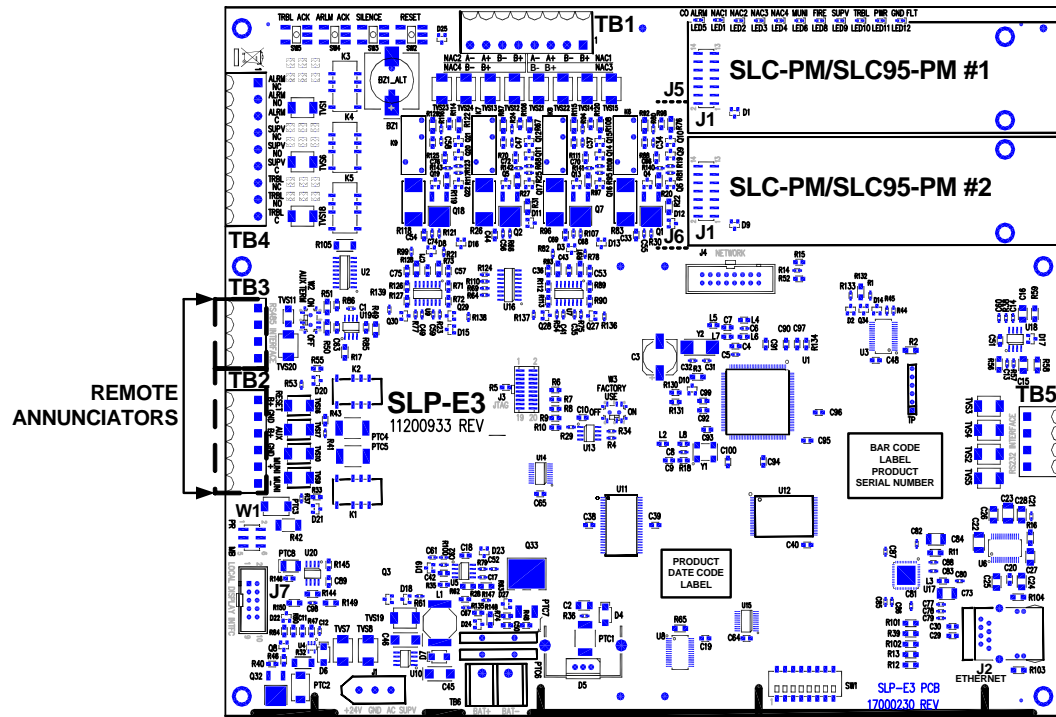

Figure 2.7.7.1 Remote Annunciator Installation Wiring Diagram

### 2.7.8 Remote Annunciator Installation Wiring Terminals

Table 2.7.8.1 lists the S3 Series, Remote Annunciator installation wiring terminals.

Designation	Description	Comments
TB2-1	RESET B+	Resettable 24 VDC Auxiliary Power
TB2-2	GND	Resettable Power Common Negative
TB2-3	AUX B+	Non-Resettable +24 VDC Auxiliary Power
TB2-4	NC	Make No Connection
TB3-1	RS485 Interface	Aux RS485 COMM A Output
TB3-2	RS485 Interface	Aux RS485 COMM B Output

Table 2.7.8.1 S3 Series, Remote Annunciator Installation Wiring Terminals

### 2.7.9 Remote Annunciator Specifications

Table 2.7.9.1 lists the specifications for the following remote annunciators connected to the SLP-E3 panel.

- ANU-48 • ASM-16 • LCD-7100 • RAN-7100 • LCD-SLP • LCD-E3

Requirements	Remote Annunciator Specifications
Circuit Supervision:	Supervised
If the circuit is power-limited:	Class 2 Power-Limited
Maximum voltage, rated current:	0.150 amp (maximum)
Maximum line voltage:	24 VDC
Maximum line impedance for Remote Annunciators:	120 Ohms
Identify the Manufacturer's Name, Model designation for appliances to be used on the circuit or reference the device compatibility section/document.	Devices hook to RS-485 for the following models: LCD-7100, LCD-E3, LCD-SLP, ASM-16 and ANU-48.
Impedance values for testing at which ground faults are annunciated.	Zero Ohms

Table 2.7.9.1 Remote Annunciator Specifications

### 2.7.10 LCD-SLP Installation Wiring Diagram

Figure 2.7.10.1 illustrates the LCD-SLP circuit board diagram. For system assembly and installation wiring terminal designations, refer to the *LCD-SLP Installation Instructions, P/N: LS10045-000GF-E*. You can download this document from the Gamewell-FCI Website ([www.gamewell-fci.com](http://www.gamewell-fci.com)).

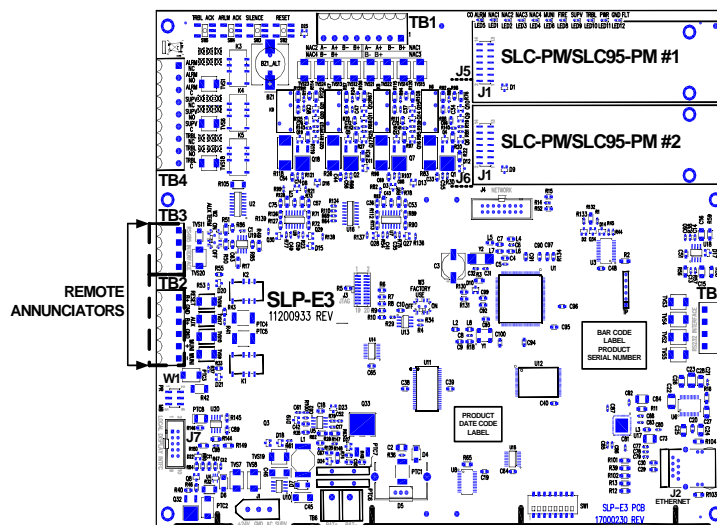

Figure 2.7.10.1 LCD-SLP Circuit Board Diagram

### 2.7.11 LCD-SLP Installation Wiring Terminals

Table 2.7.11.1 lists the LCD-SLP installation wiring designations.

Designation	Description	Comments
TB1-1	RS-485A	Communications IN (See Notes 1 & 2)
TB1-2	RS-485B	Communications IN (See Notes 1 & 2)
TB1-3	RS-485A	Communications OUT (See Note 2)
TB1-4	RS-485B	Communications OUT (See Note 2)
TB2-1	+24 V	+24 V non-resettable power IN (See Notes 1 & 2)
TB2-2	GND IN	GROUND IN (See Notes 1 & 2)
TB2-3	+24 V OUT	+24 V non-resettable power OUT (See Note 2)
TB2-4	GND OUT	GROUND OUT (See Note 2)
TB2-5	GND	Extra Ground
TB2-6	Earth Ground	Earth Ground
J5	Local Connection	RS-485 communications and power (ribbon cable local only) (See Note 3).
J6	Keypad Lock	Jumper or Keyswitch: 1. To use the Jumper, do either of the following: JMP IN = Disabled JMP OUT = Enabled OR 2. To use the keyswitch, connect the PK-625 keyswitch. This keyswitch is keyed alike with the door lock, and must be operated to activate the keypad.
W1	RS-485 Termination	W1 should be ON (top 2 pins), if it is the first or last device on the RS-485 bus. Otherwise, W1 should be OFF (bottom 2 pins).
SW1	Display Address	Binary Switch Addressing (See Note 4)
<b>NOTES</b>		
<b>NOTE 1:</b> If you do not use J5, these connections are required.		
<b>NOTE 2:</b> Use this connection only in remote installations. Do not use this connection when the LCD-SLP is mounted in the same cabinet with the SLP-E3.		

Table 2.7.11.1 LCD-SLP Installation Wiring Terminals

**NOTE 3:** Connects to the SLP-E3 J7, when the LCD-SLP is installed in the same cabinet, or similar.

**NOTE 4:**

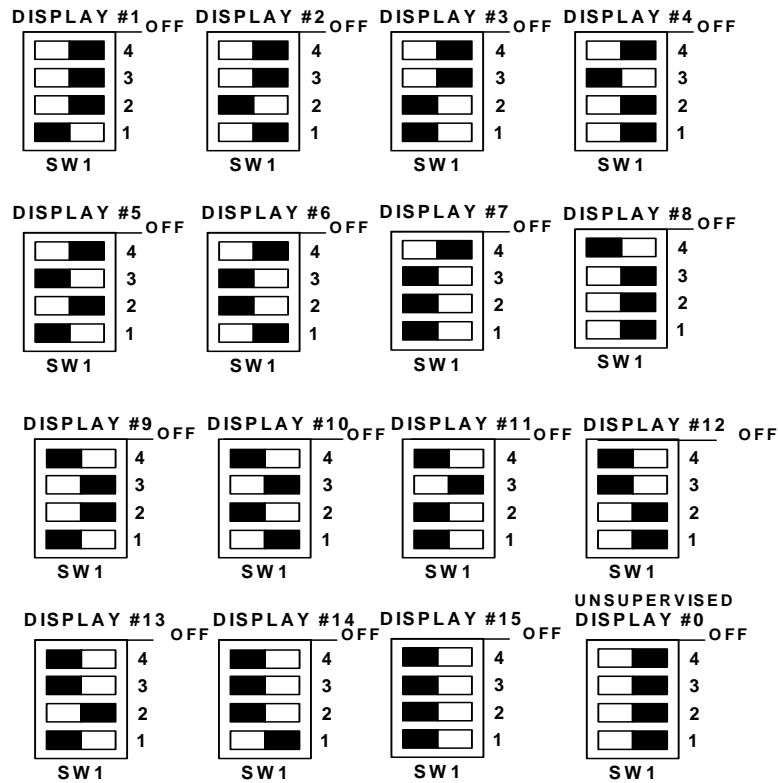

THE PANEL MUST BE PROGRAMMED TO SET THE NUMBER OF DISPLAYS FOR SUPERVISION.

**Figure 2.7.11.1 Binary Switches**

**Table 2.7.11.1 LCD-SLP Installation Wiring Terminals (Continued)**

### 2.7.12 LCD-SLP Keypad Circuit Specifications

Table 2.7.12.1 lists the LCD-SLP Keypad specifications.

Requirements	LCD-SLP Specifications
Circuit Supervision:	Supervised
Nominal Voltage, Frequency:	+ 24 VDC
Operating Standby Current:	0.030 A
Alarm Current:	0.065 A
Ground fault test impedance:	Zero Ohms
Impedance values and ground faults are annunciated:	GND Fault LED or LCD-SLP
Relative Humidity:	0 to 93%, non-condensing at 90° F (32° C)
Operating Temperature:	32° to 120° F (0° to 49° C)
Circuit Supervision:	Supervised
Circuit Power-Limited:	Class 2 Power-Limited
Maximum current amp-hour capacity:	N/A
Type of suitable battery:	N/A

**Table 2.7.12.1 LCD-SLP Keypad Specifications**

### 2.7.13 Cabinet Enclosure for LCD-SLP

Table 2.7.13.1 lists the cabinet enclosures you can use to install the LCD-SLP.

Cabinet	Part Numbers	Dimensions
SLP-BB cabinet (also called the B-Slim cabinet)	SLP-BB	14 1/2" W x 20 1/8" H x 4 1/2" D
S3 Series, B-Size Cabinet	S3BB-BB/RB	19.38" W x 19.38" H x 4.50" D
E3 Series Cabinet A2	E3BB-BA2/RA2	13.25" W x 10.00" H x 3.00" D
E3BB-FLUSH-LCD Cabinet A2	E3BB-FLUSH-LCD	13.25" W x 10.00" H x 4.50" D

**Table 2.7.13.1 Cabinet Enclosures for the LCD-SLP Display Panel**

Figure 2.7.13.1 illustrates the LCD-SLP Display Panel.



**Figure 2.7.13.1 LCD-SLP Display Panel**

## 2.8 Reverse Polarity Communication Circuit

Figure 2.8.1 illustrates the Reverse Polarity communication circuit on the SLP main board panel.

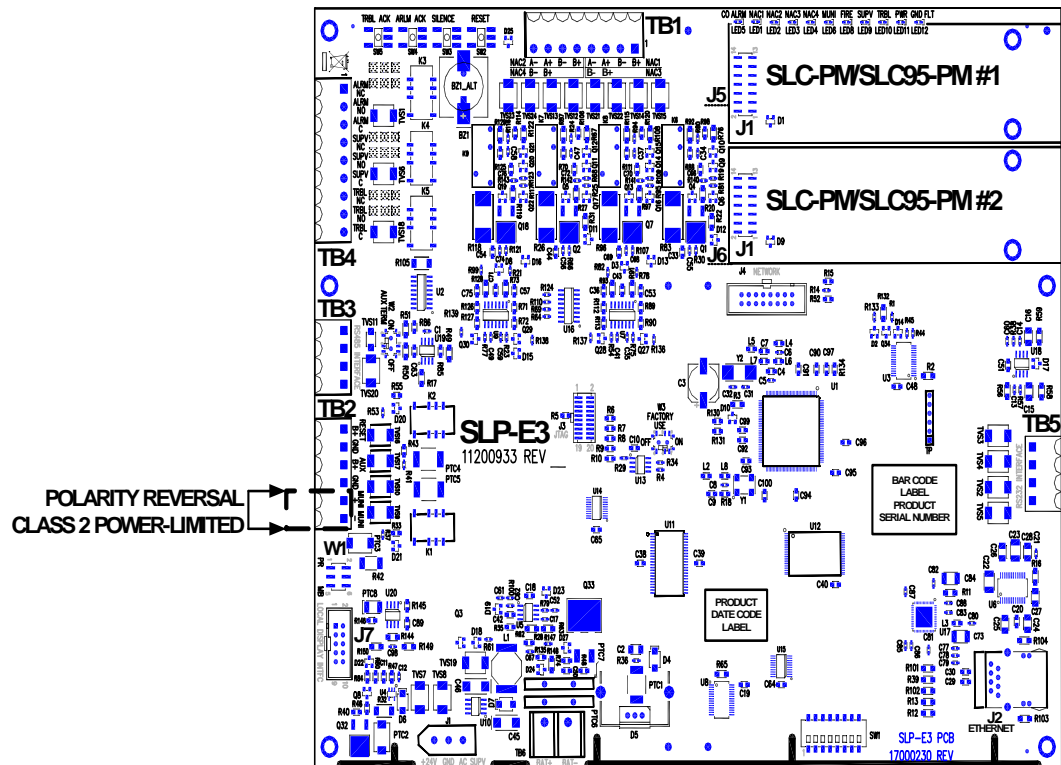
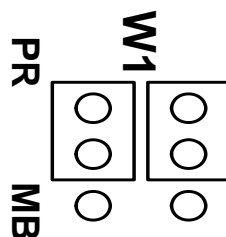

**Figure 2.8.1 Reverse Polarity Communication Line Circuit**



## 2.8.1 W1 Jumper Block (Polarity Reversal Configuration)

Figure 2.8.1.1 illustrates the W1 jumper block positions for the polarity reversal configuration.



**Figure 2.8.1.1 W1 Jumper Block Positions for Polarity Reversal**

Table 2.8.1.1 lists the Reverse Polarity communication line circuits.

Designation	Description	Comments
TB2-5	MUNI +	Positive Output to Local Energy City Box, Remote Station or Releasing Solenoid (See Figure 2.8.1.1).
TB2-6	MUNI -	Negative Output to Local Energy City Box, Remote Station or Releasing Solenoid (See Figure 2.1.1.1).

**Table 2.8.1.1 Reverse Polarity Circuit-Installation Wiring Terminals**

## 2.8.2 Reverse Polarity Circuit Specifications

Table 2.8.2.1 lists the reverse polarity circuit specifications.

Requirements	Reverse Polarity Specifications
Circuit supervision	Not Supervised
Max. voltage, rated current, and frequency	24 VDC, 0.012 amps
<b>NOTE:</b> Supervision of a polarity reversal circuit is performed by the Remote Station Receiving Unit, not the fire alarm control panel.	

**Table 2.8.2.1 Reverse Polarity Specifications**

### 2.8.2.1 Remote Station Receiving Unit Disclaimer



**DISCLAIMER:** Intended for connection to a polarity reversal circuit of a remote station receiving unit having compatible ratings.

## 2.9 Municipal Box Connection

For information on the terminal connections of the Municipal Box Connection Specifications, refer to Table 2.9.1. For information on the W1 Jumper, refer to Figure 2.9.1.1.

Requirements	Municipal Box Specifications
Circuit supervision:	Supervised
Circuit Power Requirements:	Non Power-Limited
Type of connection, series (local energy) or shunt:	Local Energy (TB3-8 and TB3-9)
Trip coil resistance value:	14.5 ohms
Trip current:	0.51 amps
Max. voltage frequency:	24 VDC
Is a shunt connection or a local energy connection pertain to the terminals. If a shunt connection is indicated, add the following next to the terminals: The shunt connection is recognized only as a supplementary signaling unit as part of a local control unit and is not recognized as an auxiliary control unit connection per NFPA 72.	Local Energy connection
Impedance values for testing at which ground faults are annunciated.	Zero Ohms

**Table 2.9.1 Municipal Box Connection Specifications**

### 2.9.1 W1 Jumper Block (Master Box/Releasing Solenoid Configuration)

Figure 2.9.1.1 illustrates the W1 jumper block positions for the Master Box/Releasing Solenoid configuration.

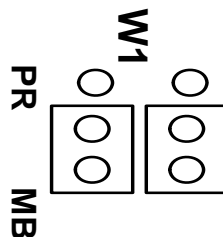

Figure 2.9.1.1 W1 Jumper Block Positions for Master Box/Releasing Solenoid

## 2.10 Communication Circuits

### 2.10.1 S3 Series System Communication Circuits

The RPT-E3-UTP is the network communication circuit for the S3 Series System. It provides a remote interface between the ILI-MB-E3/ILI95-MB-E3, ANX (used for Fire applications only) and the Broadband network. It can also be used with the NGA. Use the following network communication circuits with this system.

- RPT-E3-UTP (Repeater Module) provides unshielded, twisted-pair wire.
  - FML-E3 (Fiber-Optic Multi-Mode) provides the fiber-optic multi-mode 62.5 microns fiber.
  - FSL-E3 (Fiber-Optic Single-Mode) provides the fiber-optic single-mode 50 microns fiber.
- For system assembly and installation wiring terminal designations, refer to the following documents:
- *RPT-E3-UTP Installation Instructions, P/N: 9000-0580.*
  - *FML-E3/FSL-E3 Installation Instructions, P/N: LS10046-000GF-E.*

You can download these documents from the Gamewell-FCI Website ([www.gamewell-fci.com](http://www.gamewell-fci.com)).

### 2.10.2 RPT-E3-UTP Communication Circuit Specifications

Table 2.10.2.1 lists the RPT-E3-UTP communication circuit specifications.

Requirements	RPT-E3-UTP	FML-E3	FSL-E3
Circuit Supervision:	Supervised		
If the circuit is power-limited:	Class 2 Power-Limited		
Supervisory Current:	0.016 amp	0.053 amp	0.079 amp
Max. voltage, rated current, and frequency (RS-232 & RS-485) do not require these.	0.017 amp	0.053 amp	0.079 amp
Maximum line impedance or equivalent:	40 Ohms		

Table 2.10.2.1 RPT-E3-UTP Communication Circuit Specifications

### 2.10.3 RPT-E3-UTP Installation Wiring Diagram

Figure 2.10.3.1 illustrates the RPT-E3-UTP circuit board diagram.

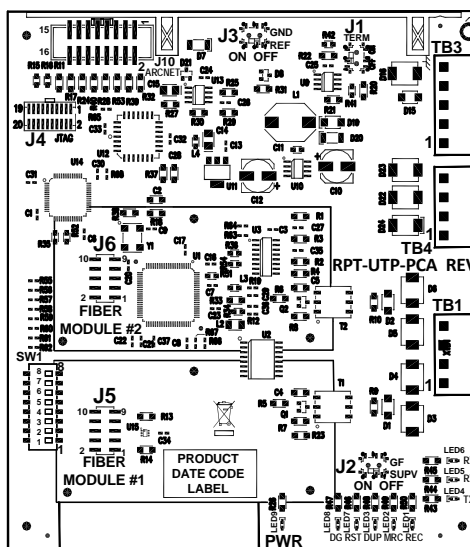

Figure 2.10.3.1 RPT-E3-UTP Circuit Board Diagram

## 2.10.4 RPT-E3-UTP Installation Wiring Terminals

Table 2.10.4.1 lists the RPT-E3-UTP terminal wiring designations.

Designation	Description	Comments
TB1-1	ARCNET PORT 1A	Broadband Network (See Note 1) For Ground Fault Supervision, PORT 1A = IN from the previous panel or node.(See Note 5).
TB1-2	ARCNET PORT 1B	Broadband Network (See Note 1) For Ground Fault Supervision, PORT 1B = IN from the previous panel or node. (See Note 5).
TB1-3	ARCNET PORT 2A	Broadband Network (See Note 1) For Ground Fault Supervision, PORT 2A = OUT to the next panel or node. (See Note 6).
TB1-4	ARCNET PORT 2B	Broadband Network (See Note 1) For Ground Fault Supervision, PORT 2B = OUT to the next panel or node. (See Note 6).
TB3-1	COM A IN	Not used when the RPT-E3-UTP is installed in the SLP-BB and the E3 Series B-Size cabinets.
TB3-2	COM B IN	Not used when the RPT-E3-UTP is installed in the SLP-BB and the E3 Series B-Size cabinets.
TB3-3	COM A OUT	Not used when the RPT-E3-UTP is installed in the SLP-BB and the E3 Series B-Size cabinets.
TB3-4	COM B OUT	Not used when the RPT-E3-UTP is installed in the SLP-BB and the E3 Series B-Size cabinets.
TB3-5	EARTH GROUND	Local Differential ARCNET (See Note 2)
TB4-1	+ 24 V IN	Not used when the RPT-E3-UTP is installed in the SLP-BB and the E3 Series B-Size cabinets.
TB4-2	Common - IN	Not used when the RPT-E3-UTP is installed in the SLP-BB and the E3 Series B-Size cabinets.
TB4-3	+ 24 V OUT	Not used when the RPT-E3-UTP is installed in the SLP-BB and the E3 Series B-Size cabinets.
TB4-4	Common - OUT	Not used when the RPT-E3-UTP is installed in the SLP-BB and the E3 Series B-Size cabinets.
J1	Switch	RS485 Termination, ON = Terminated, OFF = Un-Terminated
J2	GFI - Switch	ON = Network ground fault supervision enabled, OFF = Disabled
J3	GND FLT - Switch	ON = Earth ground drive enabled, OFF = Disabled
J4	Factory Use	Factory use
J5	Fiber Module # 1	Connection of optional Fiber-Optic module (FML-E3 or FSL-E3) for network Port 1.
J6	Fiber Module # 2	Connection of optional Fiber-Optic module (FML-E3 or FSL-E3) for Network Port 2.
J10	ARCNET	Connects to SLP-E3 J4.
<b>NOTES</b>		
<p><b>NOTE 1:</b> TB1 - RPT-E3 UTP Network Connections using unshielded, twisted-pair 18 AWG min. 3,000' (914.4 m) maximum between the following nodes:  - RPT-E3-UTP TB1-1 (COM1A) to: INI-7100 TB1-3 INI-VG TB1-3 or another RPT-E3-UTP TB1-3  - RPT-E3-UTP TB1-2 (COM1B) to: INI-7100 TB1-4 INI-VG TB1-4 or another RPT-E3-UTP TB1-4  - RPT-E3-UTP TB1-3 (COM2A) to: INI-7100 TB1-1 INI-VG TB1-1 or another RPT-E3-UTP TB1-1  - RPT-E3-UTP TB1-4 (COM2B) to: INI-7100 TB1-2 INI-VG TB1-2 or another RPT-E3-UTP TB1-2</p>		
<p><b>NOTE 2:</b> TB3-5 must be used when the RPT-E3-UTP is used remotely from a main system cabinet such as in a remote network display. Connect to a local cold water earth or via an additional conductor connected to TB3-7 of the ILI-MB-E3, ILI95-MB-E3 or ANX, Terminal TB4-4 of an INI-7100 or TB3-3 of the SLP-E3.</p>		
<p><b>NOTE 3: REMOTE NGA DISPLAY WIRING:</b>  The RPT-E3-UTP is required when you wire to a remote NGA Display. Use TB3 on the RPT-E3-UTP to connect to the NGA within the same cabinet.  <b>REMOTE NGA DISPLAY WIRING TO OTHER NETWORK PANELS:</b>  You can wire the RPT-E3-UTP in the remote NGA Display to other RPT-E3-UTPs in other network cabinets. Use TB1 on the RPT-E3-UTP, or optionally, use the fiber-optic connections on the FML-E3 or FSL-E3 to connect to other nodes in other cabinets.</p>		
<p><b>NOTE 4:</b> When J10 is used to connect the RPT-E3-UTP to the ILI-E3, ILI95-E3 Series, ANX or SLP-E3, do not use TB4.</p>		

**Table 2.10.4.1 Repeater-E3-UTP Installation Wiring Terminals**

Designation	Description	Comments
<b>NOTE 5: FIBER MODULE #1 RESTRICTION:</b> If you use TB1-1 and TB1-2 for Port 1, do not install Fiber Module #1 in connector J5.		
<b>NOTE 6: FIBER MODULE #2 RESTRICTION:</b> If you use TB1-3 and TB1-4 for Port 2, do not install Fiber Module #2 in connector J6.		

**Table 2.10.4.1 Repeater-E3-UTP Installation Wiring Terminals (Continued)**

### 2.10.5 RPT-E3-UTP Programming Address Switch Settings

To set the address, use switch SW1. Depending on the type of the network node, you can select any of the following three types of address switch settings. (See Figure 2.10.5.1, Figure 2.10.5.2 or Figure 2.10.5.3).



**NOTE:** To program the RPT-E3-UTP module, use the CAMWorks™ Software Program. For information on the latest version of CAMWorks, see the Gamewell-FCI website, [www.gamewell-fci.com](http://www.gamewell-fci.com). Installers must be Gamewell-FCI Factory Certified to program this product. For additional information on this product, contact the Gamewell-FCI Customer Support to schedule the Factory Certified Training.

**1. Standalone**

**STANDALONE = ALL SWITCHES ON**

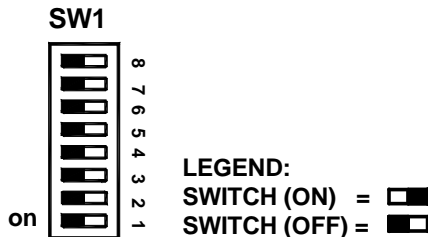

**Figure 2.10.5.1 Standalone Address Settings**

**2. E3 Series, ILI-MB-E3/ILI95-MB-E3/NGA**

**E3 SERIES,  
ILI-MB-E3/ILI95-MB-E3/NGA = ALL SWITCHES OFF**

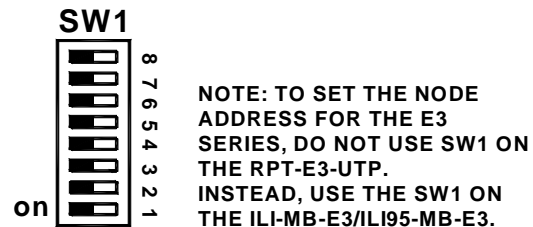

**Figure 2.10.5.2 E3 Series, ILI-MB-E3/ILI95-MB-E3/NGA Address Settings**

**3. S3 Series Panel Node Address See Figure 2.10.5.3**

Figure 2.10.5.3 illustrates the programming address switch settings for the RPT-E3-UTP connected to the S3 Series panel node address.

### ADDRESS SWITCH SETTINGS

SWITCH DOWN (ON) = [black bar on left]      SWITCH UP (OFF) = [white bar on left]

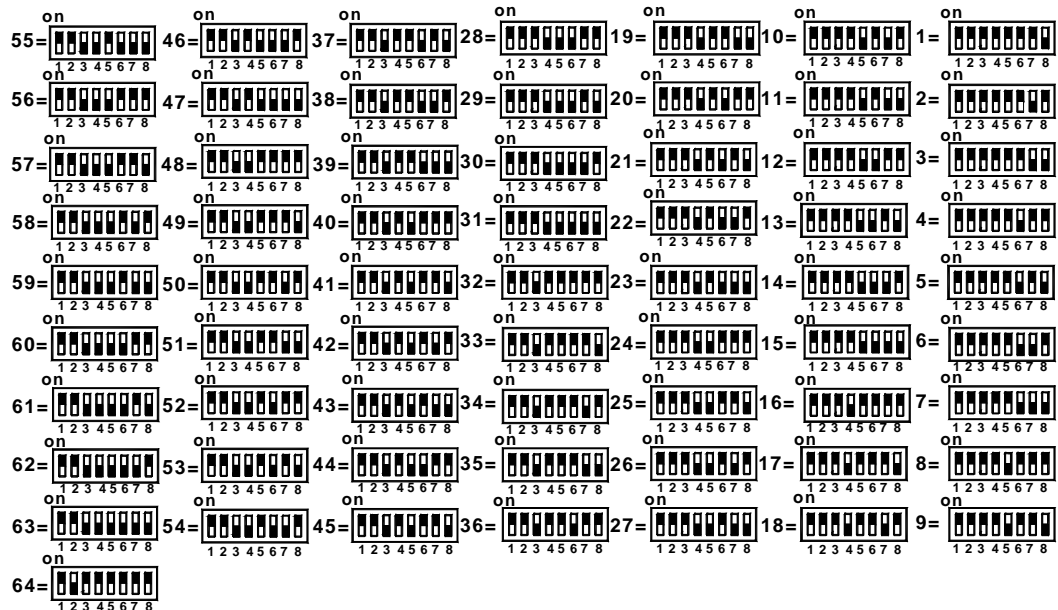

**Figure 2.10.5.3 S3 Series Panel Node Address Switch Settings**

### 2.10.6 FML-E3 Installation Wiring Diagram

The Fiber-Optic Multi-Mode (FML-E3) is an optional module that provides fiber connectivity to the network. One FML-E3 is used per a network channel to transmit/receive. Figure 2.10.6.1 illustrates the FML-E3 circuit board diagram. For system assembly and installation wiring terminal designations, refer to the *FML-E3/FSL-E3 Installation Instructions*, P/N: LS10046-000GF-E. You can download this document from the Gamewell-FCI Website (www.gamewell-fci.com).

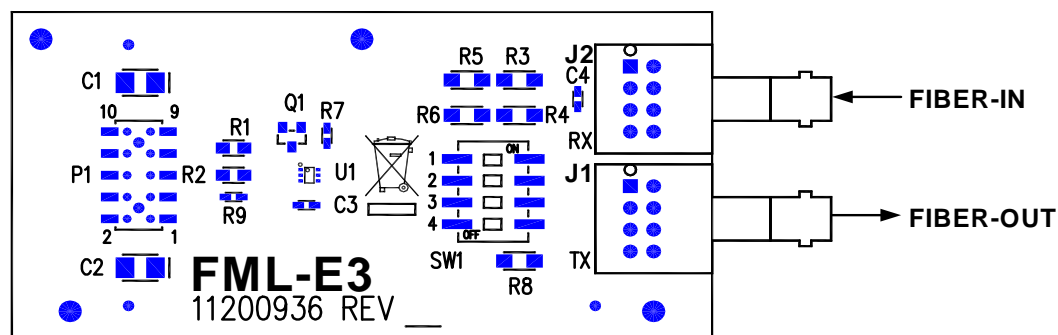

Figure 2.10.6.1 FML-E3 Circuit Board Diagram

### 2.10.7 FML-E3 Installation Wiring Terminals

Table 2.10.7.1 lists the FML-E3 installation wiring terminals.

Designation	Description
J1	Connects to the transmitting fiber. (See Note 1)
J2	Connect to the receiving fiber. (See Note 1)
SW1-1	Sets the optical output power for the transmitting fiber. (See Table 2.10.7.2)
SW1-2	Sets the optical output power for the transmitting fiber. (See Table 2.10.7.2)
SW1-3	Sets the optical output power for the transmitting fiber. (See Table 2.10.7.2)
SW1-4	Not used
P1	Plugs on to J5 (Port 1) or J6 (Port 2) of the RPT-E3-UTP.

**NOTE:** Use standard ST connector fiber-optic cable, multi-mode, up to 200 μ (optimized for 62.5/125 μ). Signal loss up to 8dB maximum between nodes.

Table 2.10.7.1 FML-E3 Installation Wiring Terminals

Table 2.10.7.2 lists the FML-E3 switch settings and drive currents.

SW1-1	SW1-2	SW1-3	Drive Current
OFF	OFF	OFF	10 mA
OFF	OFF	ON	20 mA
OFF	ON	OFF	32 mA
OFF	ON	ON	42 mA
ON	OFF	OFF	54 mA
ON	OFF	ON	64 mA
ON	ON	OFF	76 mA
ON	ON	ON	86 mA

**NOTE:** SW1-4 is not used.

Table 2.10.7.2 FML-E3 Switch Settings and Drive Currents

### 2.10.8 FSL-E3 Installation Wiring Diagram

The Fiber-Optic Single-Mode (FSL-E3) is an optional module that provides fiber connectivity to the network. One FSL-E3 is used per a network channel to transmit/receive. Figure 2.10.8.1 lists the FSL-E3 (Fiber-Optic Single-Mode) circuit board diagram. For system assembly and installation wiring terminal designations, refer to the *FML-E3/FSL-E3 Installation Instructions, P/N: LS10046-000GF-E*. You can download this document from the Gamewell-FCI Website ([www.gamewell-fci.com](http://www.gamewell-fci.com)).

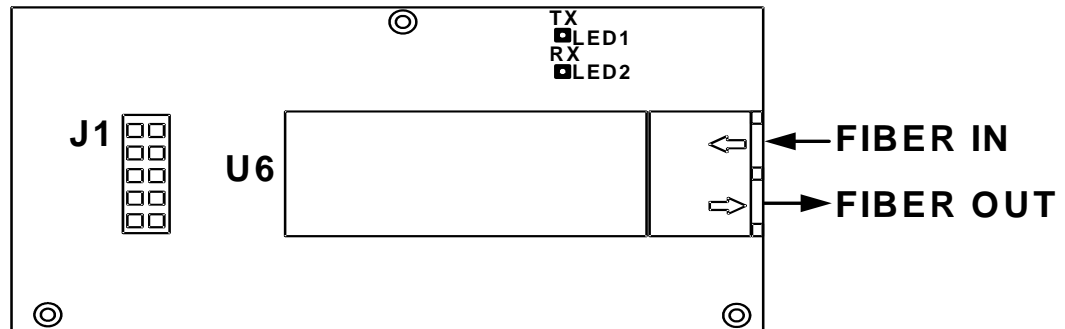

Figure 2.10.8.1 FSL-E3 Circuit Board Diagram

### 2.10.9 FSL-E3 Installation Wiring Terminals

Table 2.10.9.1 lists the FSL-E3 terminal wiring designations.

Designation	Description
J1	Plugs on to J5 (Port 1) or J6 (Port 2) of the RPT-E3-UTP.
<b>NOTE:</b> Use LC connector fiber-optic cable, single mode, up to 1310 nm (optimized for 9/125 μ). Signal loss up to 30 dB maximum between nodes.	

Table 2.10.9.1 FSL-E3 Installation Wiring Terminals

### 2.10.10 DACT-E3 Communication Circuit

Use the DACT-E3 as the remote monitoring circuit for the S3 Series System. The DACT-E3 provides for separate transmissions for Alarm versus Trouble and Supervisory Events for the Remote Station Service. DACT reporting of primary AC power failure maybe delayed. For information on the Programming Features, refer to in Section 5.

For system assembly and installation wiring terminal designations and specifications, refer to the *DACT-E3 Installation Instructions, P/N: 9000-0581*. You can download this document from the Gamewell-FCI Website ([www.gamewell-fci.com](http://www.gamewell-fci.com)).

## 2.11 Power Output Circuits

Figure 2.11.1 illustrates the location of the power output circuits for the SLP main board panel.

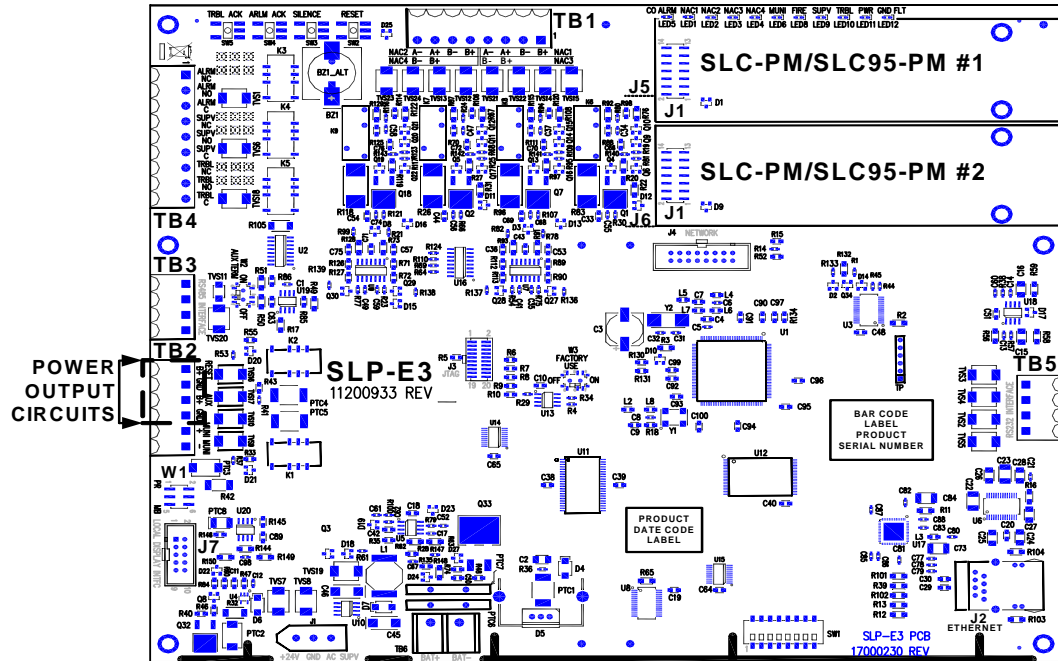

Figure 2.11.1 Power Output Circuits

Table 2.11.1 lists the power output circuit terminal wiring designations.

Designation	Description	Comments
TB2-1	RESET B+	Resettable 24 VDC Auxiliary Power
TB2-2	GND	Resettable Power Common Negative
TB2-3	AUX B+	Non-resettable 24 VDC Auxiliary Power
TB2-4	NC	Make No Connection

Table 2.11.1 Power Output Circuit - Installation Wiring Terminals

### 2.11.1 Power Output Specifications

Table 2.11.1.1 lists the power output specifications.

Requirements	Power Output Specifications
Circuit Supervision:	Supervised
If the circuit is power-limited:	Class 2 Power-Limited
For Special Applications Notification Appliances, there shall be a list of devices with the manufacturer and part number information that can be connected when NAC is selected as a special application.	Max. Alarm Load: - Class A, 2.0 A/circuit Special Applications @ 24 VDC nominal Class B, 2.0 A/circuit Special Applications @ 24 VDC nominal Class A, 0.2 A/circuit Regulated @ 24 VDC nominal Class B, 0.2 A/circuit Regulated @ 24 VDC nominal <i>NOTE: For additional information on the compatible devices with the Manufacturer's name and model number, refer to the Compatibility Addendum for Gamewell-FCI Manuals.</i>
For Regulated Output:	0.2A at 24 VDC nominal
Identify the Manufacturer's Name, model designation for appliances to be used on the circuit.	Refer to the Compatibility Addendum to Gamewell-FCI Manuals, P/N: 9000-0427-L8.
Impedance values for testing at which ground faults are annunciated when ground faults affect operation.	Zero Ohms
Power output circuit battery backed-up or not.	Yes
See General Wiring for duplicate terminal requirements.	N/A

Table 2.11.1.1 Power Output Specifications

## 2.12 Releasing Device Circuit

Figure 2.12.1 illustrates the Releasing Device circuit on the SLP main board panel.

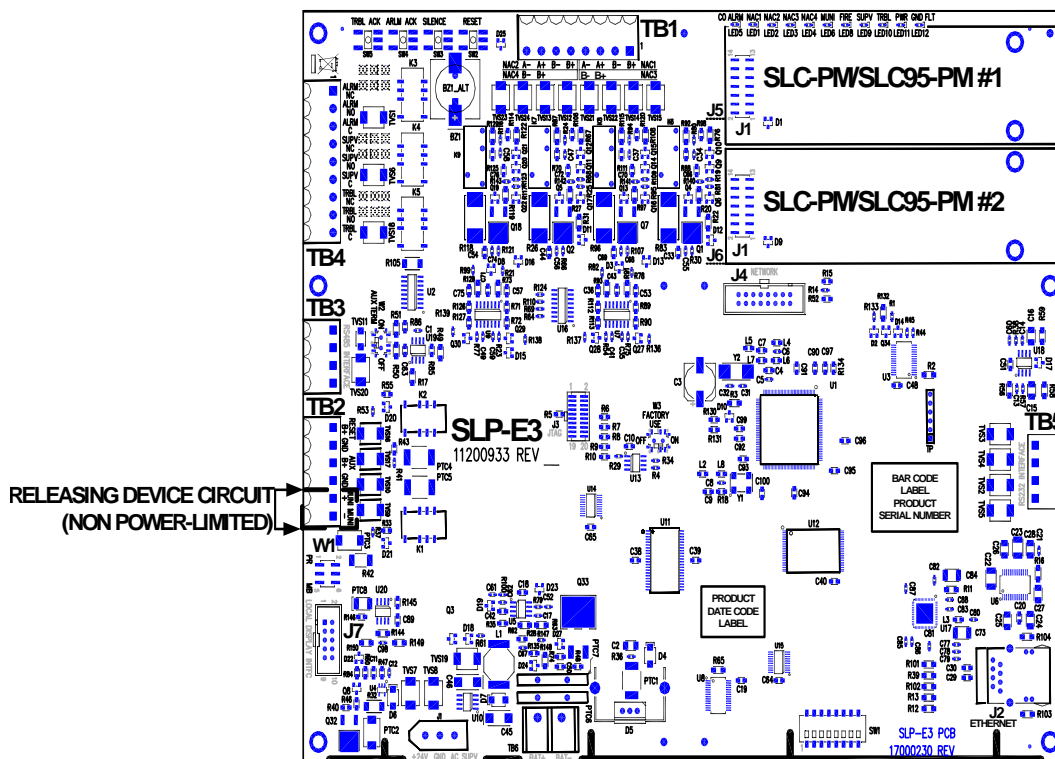

Figure 2.12.1 Releasing Device Circuit

Table 2.12.1 lists the Releasing Device circuit terminal designations.

Designation	Description	Comments
TB2-5	MUNI +	Negative Output to Local Energy City Box, Remote Station or Releasing Solenoid. (See Figure 2.12.1)
TB2-6	MUNI -	Negative Output to Local Energy City Box, Remote Station or Releasing Solenoid. (See Figure 2.12.1)

Table 2.12.1 Releasing Device - Installation Wiring Terminals

### 2.12.1 Releasing Device Circuit Specifications

Table 2.12.1.1 lists the Releasing Device Circuit specifications.

Requirements	Releasing Device Specifications
Circuit supervision:	Supervised
Circuit Power Requirements:	Class 2 Power-Limited
Maximum voltage, rated current, and frequency:	27.5 VDC, 0.081 A
Maximum current:	0.700 A
Specific releasing devices by Manufacturer's name and model for connection to the circuit.	Refer to the Compatibility Addendum to Gamewell-FCI Installation/Operation Manuals UL File S1869 Vol. 8C, P/N: 9000-0427-L8.
Impedance values for testing at which ground faults are annunciated when ground faults affect the operation.	Zero Ohms

Table 2.12.1.1 Releasing Device Specifications



**NOTE:** Releasing activation upon alarm may optionally be delayed by user Configuration Programming using CAMWorks.



## 2.13 Relay Circuit, Open Collector and Other Similar Outputs

Figure 2.13.1 illustrates the Relay, Open Collector and other similar outputs on the SLP main board panel.

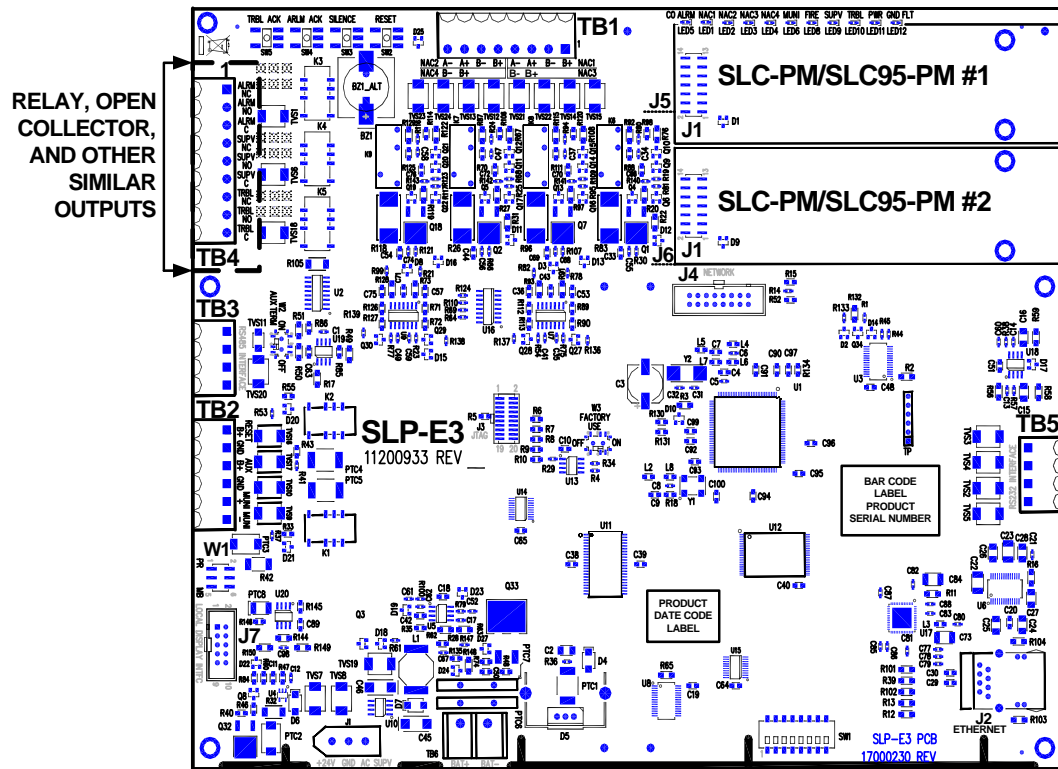

Figure 2.13.1 Relay, Open Collector and Other Outputs

Table 2.13.1 lists the relay circuit outputs for the SLP main board.

Designation	Description	Comments
TB4-1	ALRM NC	Alarm relay contact normally CLOSED N/C
TB4-2	ALRM NO	Alarm relay contact normally OPEN N/O
TB4-3	ALRM C	Alarm relay contact common
TB4-4	SUPV NC	Supervisory relay contact normally CLOSED N/C
TB4-5	SUPV NO	Supervisory relay contact normally OPEN N/O
TB4-6	SUPV C	Supervisory relay contact common
TB4-7	TRBL NC	Trouble relay contact normally CLOSED N/C
TB4-8	TRBL NO	Trouble relay contact normally OPEN N/C
TB4-9	TRBL C	Trouble relay contact common

Table 2.13.1 SLP Relay Circuit Outputs-Installation Wiring Terminals

### 2.13.1 Relay Circuit Specifications

Table 2.13.1.1 lists the relay circuit specifications.

Requirements	Relay Circuit Specifications
Circuit supervision:	Not Supervised
Circuit Power Requirements:	N/A
Designated as “Common,” “Zone,” or “Programmable”:	The Alarm and Supervisory relays are either Common or Programmable (depending on the configuration settings). The Trouble Relay is Common.
Loading in voltage, current, frequency, and for relays, power factor (if power factor is not specified, it will be assumed to be .35 inductive).	30 VDC, 2A (max.)

Table 2.13.1.1 Relay Circuit Specifications

## 2.14 S3 Series System, SLP-BB Cabinet Assembly

The SLP-BB (Smart Loop Panel-Backbox) (Part Number: SLP-BB) assembly typically houses the following units:

- Backbox
  - SLP Main Board
  - SLC-PM/SLC95-PM
  - FLSP-7 Power Supply
  - Batteries
  - RPT-E3-UTP (Optional)
  - DACT-E3 (Optional)
- Outer Door
  - LCD-SLP Display Panel
  - Door Insert
- Hardware Kit

### 2.14.1 SLP-BB Cabinet Installation

Figure 2.14.1.1 illustrates the SLP-BB cabinet dimensions.

Figure 2.14.1.2 illustrates the SLP-BB outer door and backbox installation.

To install the SLP-BB outer door to the backbox, refer to the following.

1. To mount the SLP-BB outer door to the backbox, insert four nuts (#6 Hex Kep) in the four-hole mounting pattern and secure the nuts from the outer door to the left side of the backbox as shown in Locations 1, 2, 3 and 4 of Figure 2.14.1.2.



**NOTE:** Use the Hardware Kit provided with the SLP-BB Cabinet assembly.

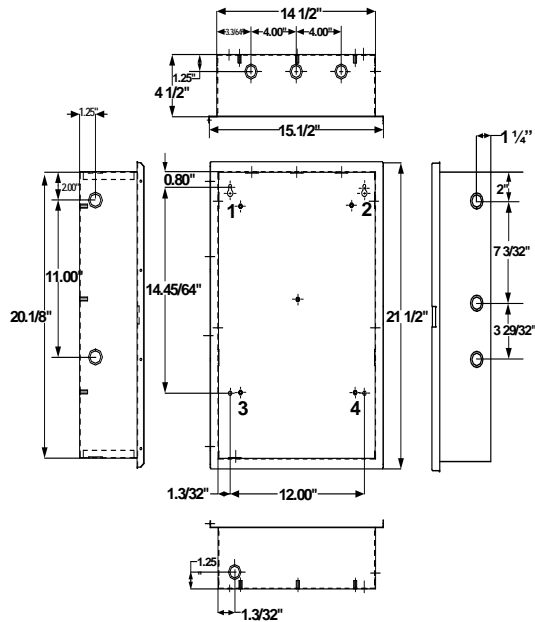

Figure 2.14.1.1 SLP-BB Cabinet Dimensions

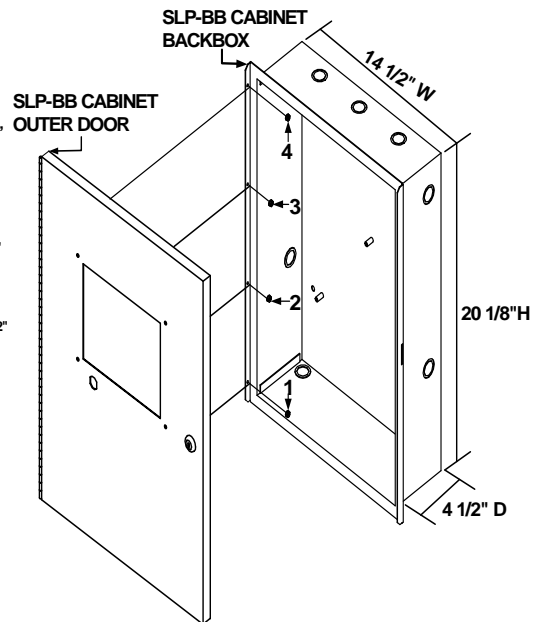

Figure 2.14.1.2 SLP-BB Outer Door to Backbox Assembly

## 2.15 Separation of Circuits

### 2.15.1 S3 Series, SLP-BB Cabinet, Class 2 Power-Limited/Non Power-Limited Wiring Requirements

UL Standard 864, (Control Units for Fire Protective Signaling Systems), requires that a minimum of 1/4 inch separation be maintained between Class 2 power-limited circuits and non power-limited circuits. The control unit is designed so that the required separation between these circuits (Class 2 power-limited vs. non power-limited) is maintained at the field wiring terminals.

In order to fully comply with the intent of these requirements, however, the minimum 1/4 inch separation must also be maintained between the field wiring conductors of Class 2 power-limited circuits and non power-limited circuits. This may be accomplished by routing the field wiring as shown in Figure 2.15.1.1 and Figure 2.15.1.2.

Unless otherwise indicated on the unit, all field-wiring circuits are Class 2 power-limited except:

- AC power circuit
- Standby battery circuit
- Telephone line connections
- Master Box / Releasing

Figure 2.15.1.1 illustrates the S3 Series System, SLP-BB Cabinet, Class 2 power-limited and non-power-limited wiring extending from the DACT-E3, RPT-E3-UTP and SLC-PM/SLC95-PM modules.

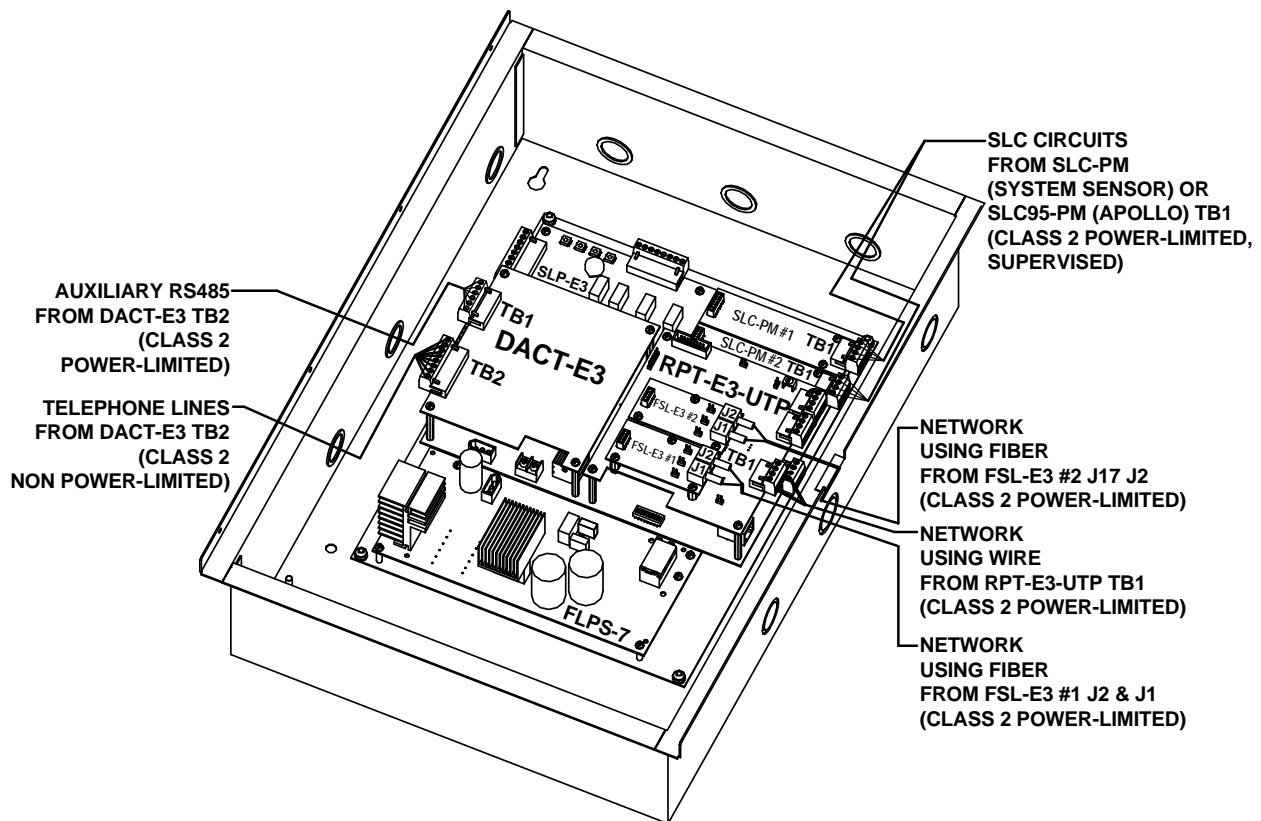

**Figure 2.15.1.1 S3 Series, SLP-BB Cabinet, Class 2 Power-Limited and Non-Power-Limited Wiring (Basic Bottom Level Circuit Board Configuration)**

Figure 2.15.1.2 illustrates the S3 Series System unit, Class 2 power-limited and non-power-limited wiring extending from the SLP-E3 and FLPS-7 modules.

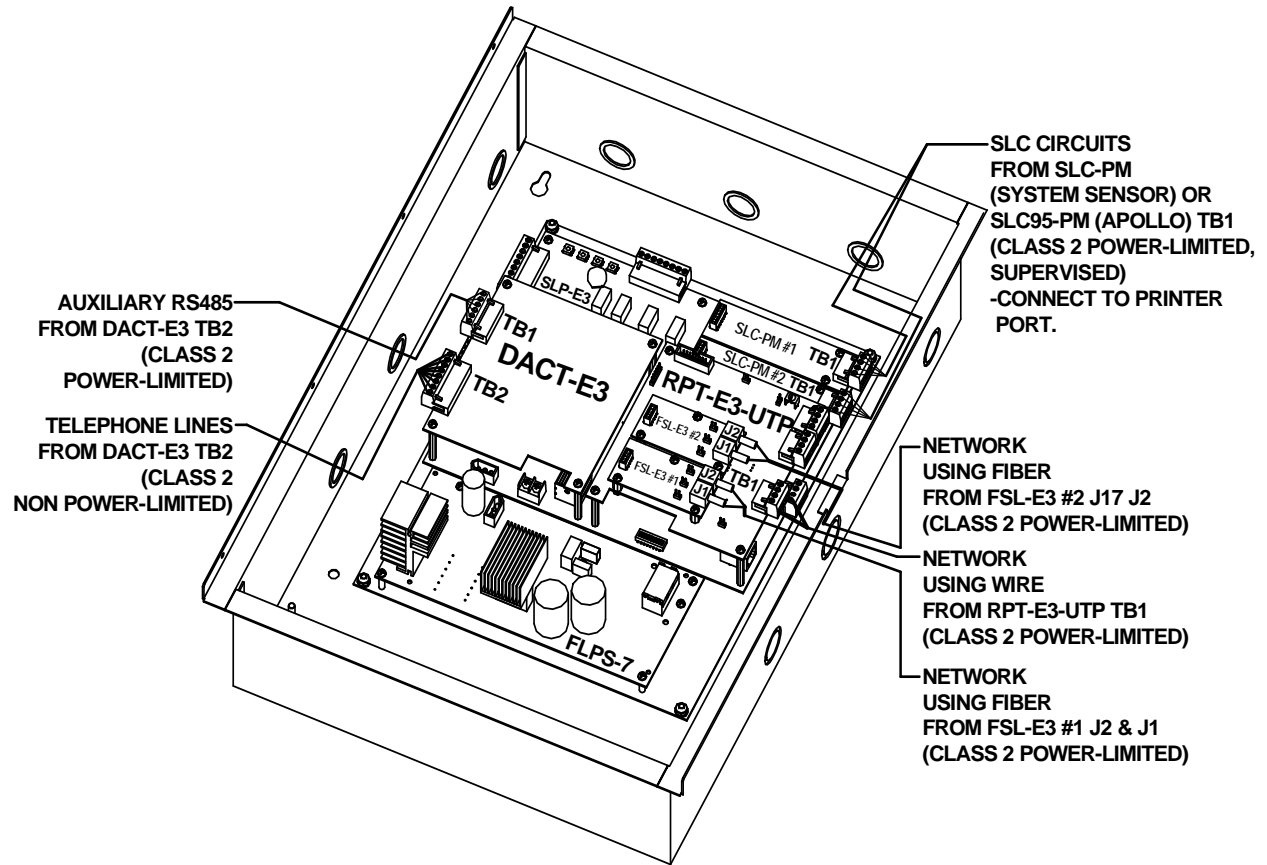

**Figure 2.15.1.2 S3 Series, SLP-BB Cabinet, Class 2 Power-Limited and Non-Power-Limited Wiring (Optional Top Level Circuit Board Configuration)**

## 2.16 S3 Series System, B-Size Cabinet Assembly

The S3 Series, B-Size cabinet assembly (Part Number: E3BB-BB/RB) typically houses the following units:

- Backbox
  - SLP Main Board
  - SLC-PM/SLC95-PM
  - FLPS-7 Power Supply
  - Batteries
  - RPT-E3-UTP (Optional)
  - DACT-E3 (Optional)
- Inner Door
  - LCD-SLP Display Panel
  - ANU-48 (Optional)
  - ASM-16 (Optional)
  - LCD-E3 (Optional)
- Outer Door
  - Door Insert
- Hardware Kit

### 2.16.1 S3 Series, B-Size Cabinet Installation

Figure 2.16.1.1 illustrates the S3 Series, B-Size cabinet dimensions.

Figure 2.16.1.2 illustrates the S3 Series, B-Size cabinet outer door and backbox installation. For installation instructions, refer to the following:

1. To mount the outer door to the backbox, insert four, #6 nuts in the four-hole mounting pattern and secure the nuts from the outer door to the left side of the backbox as shown in Locations 1, 2, 3 and 4 of Figure 2.16.1.2.



**NOTE:** Use the Hardware Kit provided with the S3 Series, B-Size Cabinet assembly.

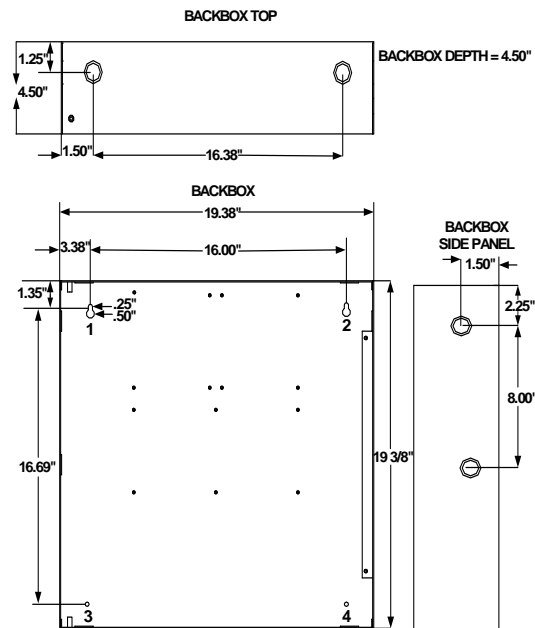

Figure 2.16.1.1 S3 Series, B-Size Cabinet Dimensions

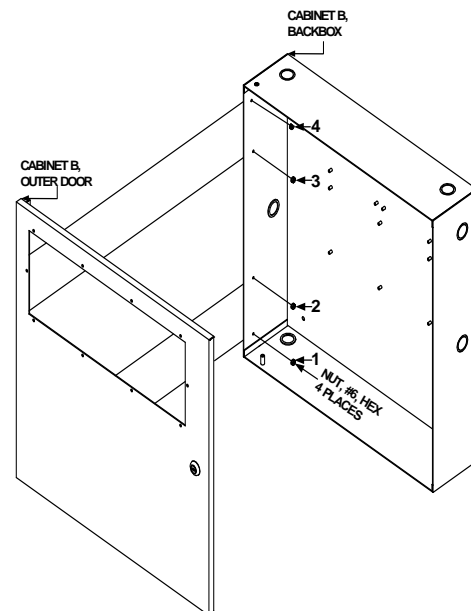

Figure 2.16.1.2 S3 Series Cabinet B, Outer Door to Backbox Installation

## 2.17 Separation of Circuits

### 2.17.1 S3 Series, B-Size Cabinet, Class 2 Power-Limited/Non Power-Limited Wiring Requirements

UL Standard 864, (Control Units for Fire Protective Signaling Systems), requires that a minimum of 1/4 inch separation be maintained between Class 2 power-limited circuits and non power-limited circuits. The control unit is designed so the required separation between these circuits (Class 2 power-limited vs. non power-limited) is maintained at the field wiring terminals.

In order to fully comply with the intent of these requirements, however, the minimum 1/4 inch separation must also be maintained between the field wiring conductors of Class 2 power-limited circuits and non power-limited circuits. This may be accomplished by routing the field wiring as shown in Figure 2.17.1.1 and Figure 2.17.1.2.

Unless otherwise indicated on the unit, all field-wiring circuits are Class 2 power-limited except:

- AC power circuit
- Standby battery circuit
- Telephone line connections
- Master Box / Releasing

Figure 2.17.1.1 illustrates the S3 Series System, B-Size cabinet, Class 2 power-limited and non-power-limited wiring extending from the SLP-E3 and FLPS-7 modules.

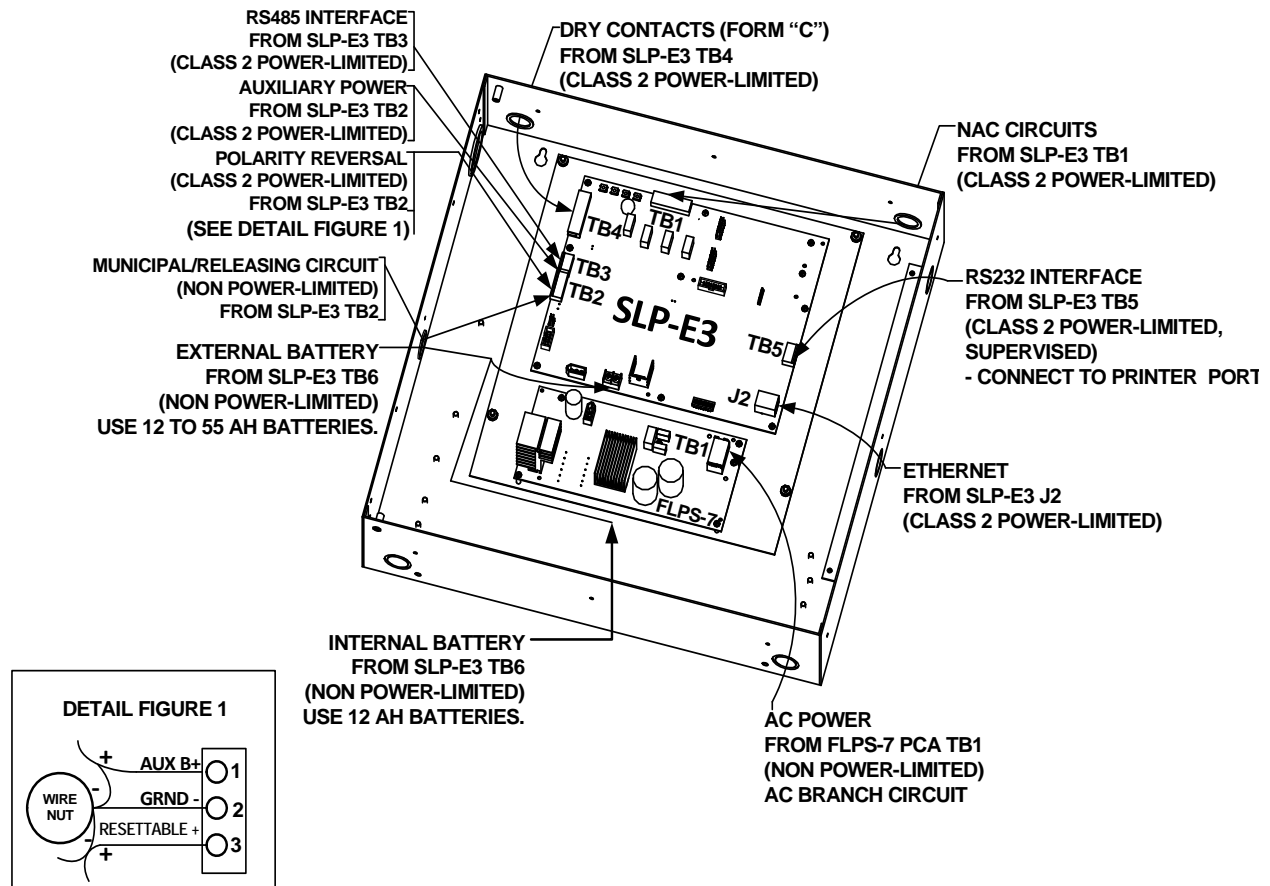
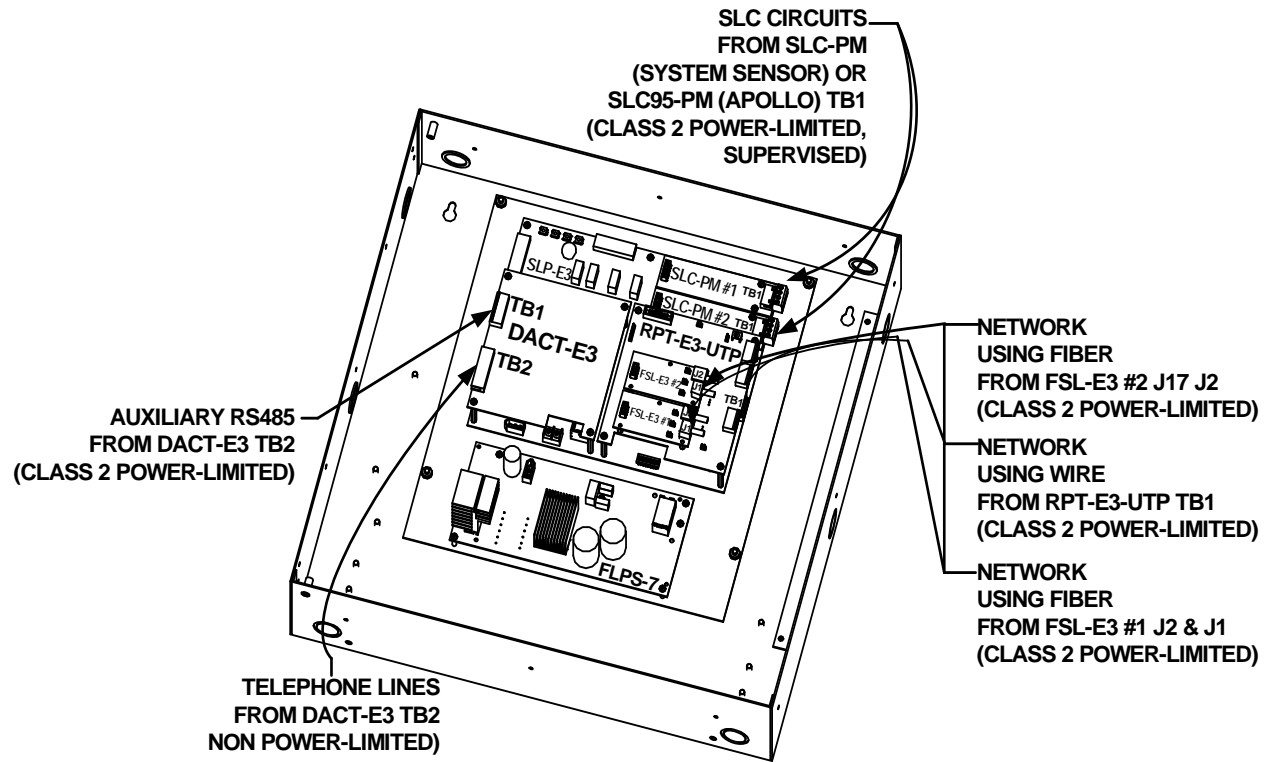

Figure 2.17.1.1 S3 Series, B-Size Cabinet, Class 2 Power-Limited and Non-Power-Limited Wiring (Basic Bottom Level Circuit Board Configuration)

Figure 2.17.1.2 illustrates the S3 Series System, B-Size cabinet, Class 2 power-limited and non-power-limited wiring extending from the optional top level circuit board configuration.



**Figure 2.17.1.2 S3 Series, B-Size Cabinet, Class 2 Power-Limited and Non-Power-Limited Wiring (Optional Top Level Circuit Board Configuration)**

## 2.18 E3 Series, Cabinet A2 Assembly

The E3 Series, Cabinet A2 assembly (Part Number: E3BB-BA2/RA2) typically houses the following units:

- Backbox
- Inner Door
  - LCD-SLP Display Panel
  - LCD-E3 (Optional)
- Outer Door
  - Door Insert
- Hardware Kit

### 2.18.1 E3 Series, Cabinet A2 Installation

Figure 2.18.1.1 illustrates the E3 Series, Cabinet A2 dimensions.



**NOTE:** Use the Hardware Kit provided with the E3 Series, Cabinet A2 assembly.

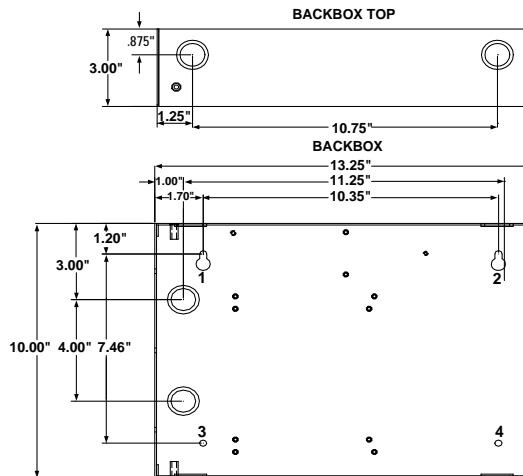

**Figure 2.18.1.1 E3 Series, Cabinet A2 Dimensions**

#### 2.18.1.1 E3 Series Cabinet A2 Outer Door to Backbox Installation

To install the E3 Series Cabinet A2 outer door to the backbox, refer to the following.

1. Mount the outer door to the backbox.
2. Insert three nuts (#6-32) in the three-hole mounting pattern and secure the nuts from the outer door to the left side of the backbox as shown in Locations 1, 2 and 3 in the figure below.

Figure 2.18.1.1.1 illustrates the E3 Series Cabinet A2, outer door to the backbox installation.

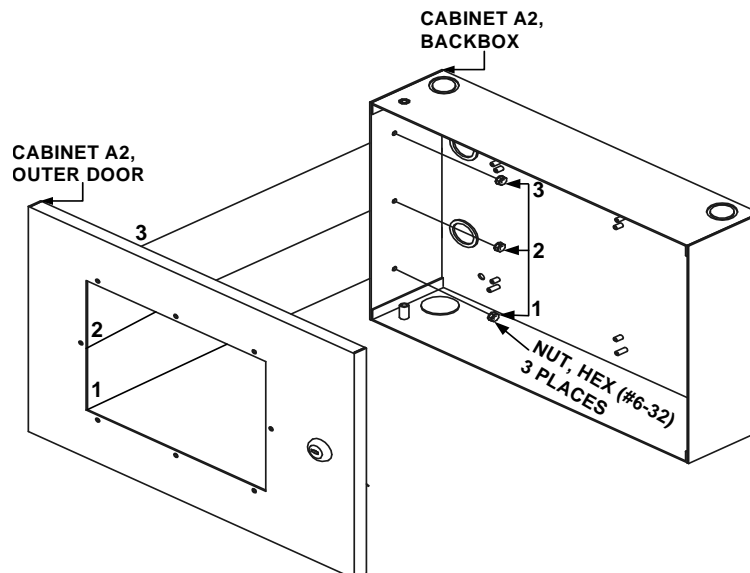

**Figure 2.18.1.1.1 E3 Series Cabinet A2, Outer Door to Backbox Installation**



### 2.18.1.2 E3 Series Cabinet A2, Sub-Assembly to the Inner Door Installation

Figure 2.18.1.2.1 illustrates the LCD-SLP remote annunciator connected to the E3 Series Cabinet A2 inner door installation.

1. To connect the LCD-SLP to the inner door, insert and secure four, #6-32 nuts in the four-hole mounting pattern as shown in Location 1 in the figure below. The LCD-E3 may be installed in Cabinet A2.
2. Secure the opposite end of the bonding wire to the welded #6 stud on the inner side of the inner door using the #6 nut as shown in Location 2 in the figure below.

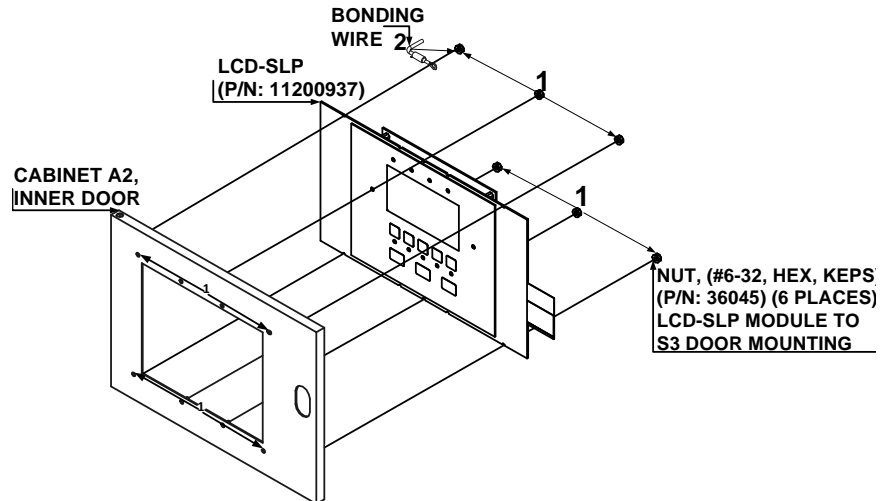

Figure 2.18.1.2.1 E3 Series Cabinet A2, Sub-Assembly to the Inner Door Installation

## 2.19 E3BB-FLUSH-LCD Cabinet A2 Assembly

The E3 Series, E3BB-FLUSH-LCD Cabinet A2 assembly (Part Number: E3BB-FLUSH-LCD) typically houses the following units:

- Backbox
- Outer Door
  - LCD-SLP Display Panel
  - LCD-E3 (Optional)
- Hardware Kit

### 2.19.1 E3BB-FLUSH-LCD Cabinet A2 Installation

Figure 2.19.1.1 illustrates the E3 Series, E3BB-FLUSH-LCD Cabinet A2 dimensions.



**NOTE:** Use the Hardware Kit provided with the E3BB-FLUSH-LCD, Cabinet A2 assembly.

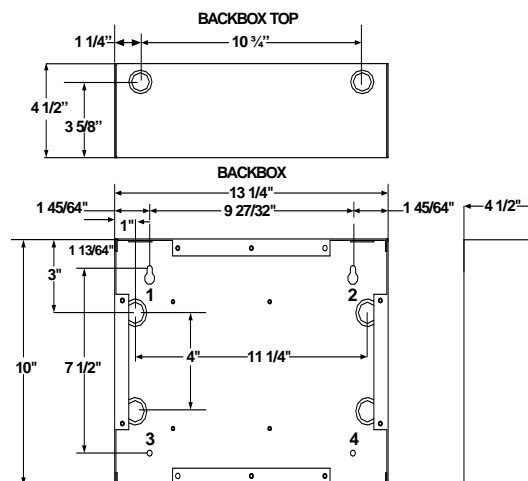

Figure 2.19.1.1 E3BB-FLUSH-LCD Cabinet A2 Dimensions

### 2.19.1.1 E3BB-FLUSH-LCD Cabinet A2 Front Cover to Backbox Installation

Figure 2.19.1.1.1 illustrates the E3BB-FLUSH-LCD front cover to the backbox installation.

1. Mount the keyswitch to the E3BB-FLUSH-LCD Flush Mount Front Cover and secure with one, nut (3/4-24 THD Hex) as shown in Location 1 in the figure below.
2. Attach the keyswitch cable to the key as shown in Location 2 in the figure below.
3. To mount the LCD-SLP keypad to the E3BB-FLUSH-LCD Flush Mount Front Cover, insert eight nuts (#6-32, Hex Keps) in the eight-hole mounting pattern and secure the nuts from the keypad to the front cover as shown in Location 3 in the figure below.
4. Plug-in the P2 keyswitch cable to the W2 terminal on the LCD-SLP display as shown in Location 4 in the figure below.
5. Attach the E3BB-FLUSH-LCD Flush Mount Front Cover to the backbox.
6. Insert eight screws (#6-32 x 3/8" PHBHD, BLK) in the eight-hole mounting pattern and secure the screws from the front cover to the backbox as shown in Location 5 in the figure below.

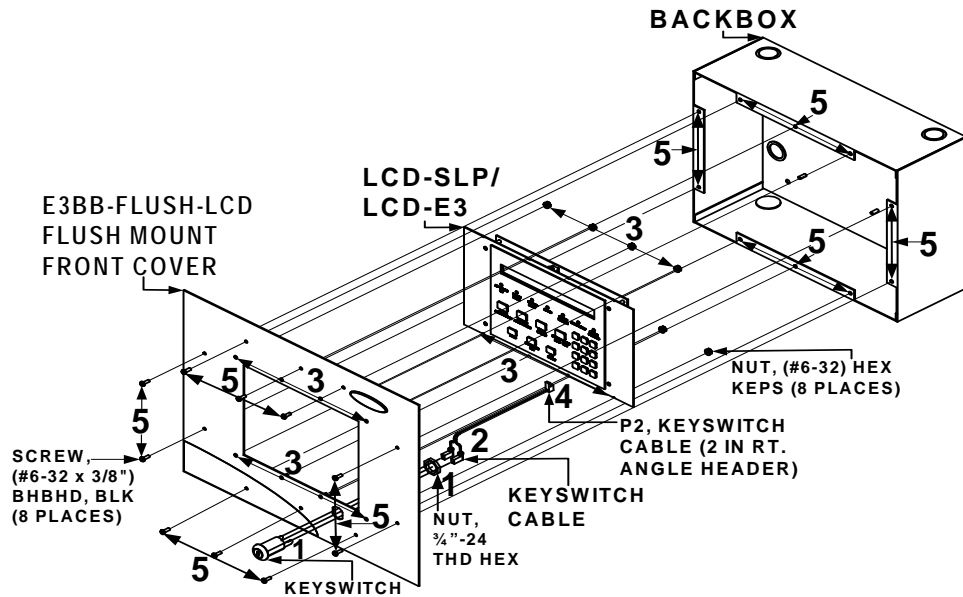

Figure 2.19.1.1.1 E3BB-FLUSH-LCD Cabinet A2 Installation

## 2.20 S3 Series System Configuration

Figure 2.20.1 illustrates an overview of the S3 Series System configuration.

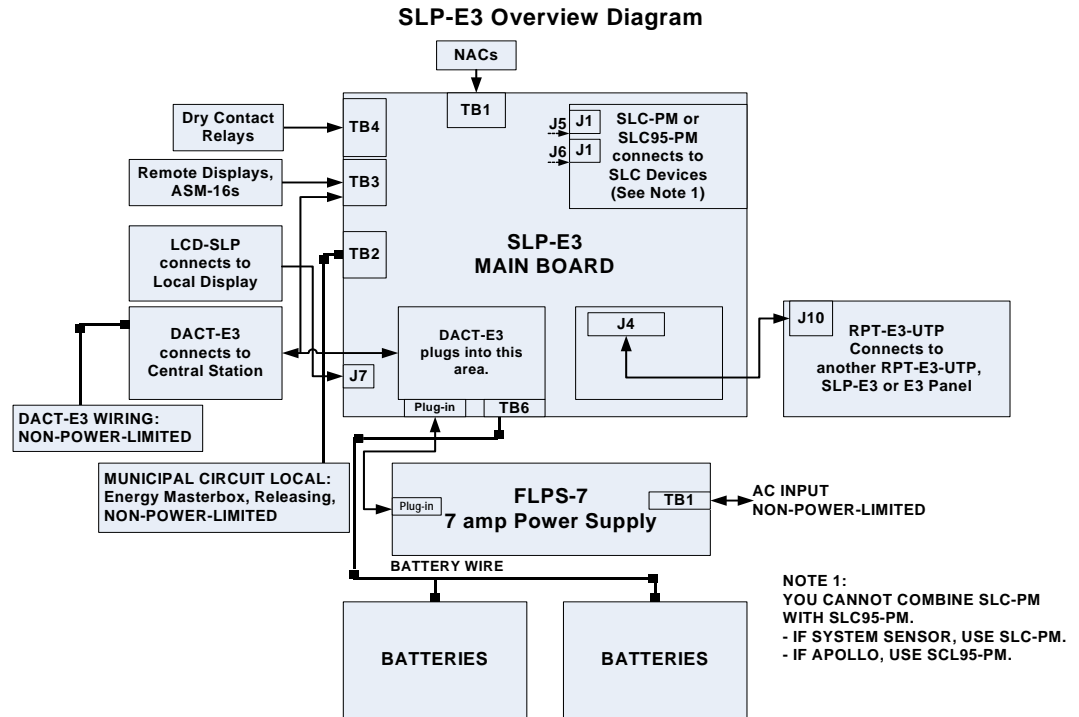

Figure 2.20.1 S3 Series System Configuration

## Section 3: Operation

### 3.1 LCD-SLP Operation

#### 3.1.1 LCD-SLP Panel Display Operation

The LCD-SLP is a 4.3" diagonal, 480 x 272 pixels touchscreen display of system events including indicating LEDs and control switches. It may be remotely located via a local RS-485 serial interface. The SLP-E3 will support up to fifteen, LCD-SLP displays. See Table 3.1.2.1 for the LED indicators and descriptions.

#### 3.1.2 LCD-SLP LED Indicators/Annunciators

Figure 3.1.2.1 illustrates the LED indicators/annunciators. Table 3.1.2.1 lists the LCD-SLP indicators/annunciators and a description.

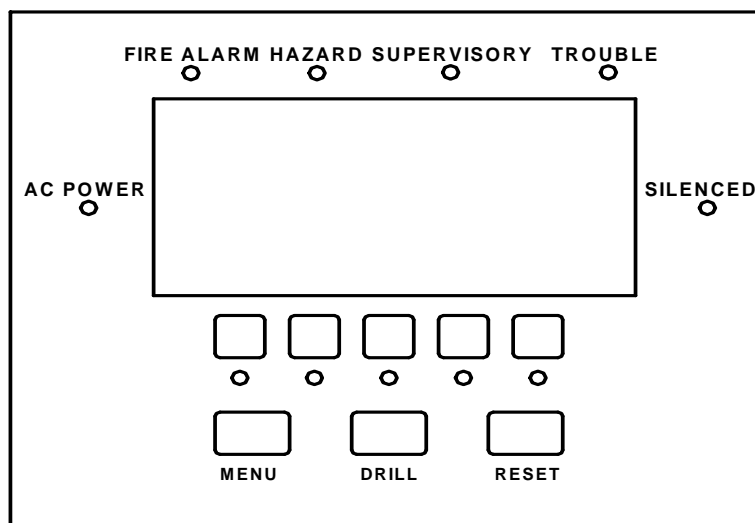

Figure 3.1.2.1 LCD-SLP LED Indicators/Annunciators

Designation	Description	Comments
AC	(green)	Lights to indicate the presence of AC voltage input.
Fire Alarm	(red)	Lights when system is in alarm, flashes until alarm is acknowledged.
Hazard	(blue)	Lights to indicate a hazard condition. Flashes until acknowledged.
Supervisory	(yellow)	Lights when supervisory condition. Flashes until event is acknowledged.
Trouble	(yellow)	Lights to indicate trouble condition, flashes until trouble is acknowledged.
Silenced	(yellow)	Lights when the System Silence is pressed. Flashes when the System Silence is pending. It does not reflect the battery condition.

Table 3.1.2.1 LCD-SLP LED Indicators/Annunciators

#### 3.1.3 LCD-SLP Audible/Visual Condition Indications

Table 3.1.3.1 lists the Audible/Visual Condition Indicators.

Condition	Audible/Visual Status Indication
<b>Alarm</b>	Alarm situations are indicated by a one-half second ON and one-half second OFF pattern from the system sounder and the illumination of the red alarm LED.
<b>Hazard</b>	Hazard situations are indicated by a one-half second ON and one-half second OFF pattern from the system sounder and the illumination of the blue alarm LED.
<b>Supervisory</b>	Supervisory events are indicated by a continuous tone or optional supervisory cadence from the system piezo sounder and the illumination of the supervisory LED. Optional Cadence is 1 sec. ON and .9 sec. OFF repeating.
<b>Trouble</b>	Trouble conditions are indicated by a continuous tone from the system piezo sounder and the illumination of the yellow trouble LED.

Table 3.1.3.1 Audible/Visual Condition Indicators

### 3.1.4 LCD-SLP Switches

Figure 3.1.4.1 illustrates the LCD-SLP switches. Table 3.1.4.1 lists the LCD-SLP switches and a description.

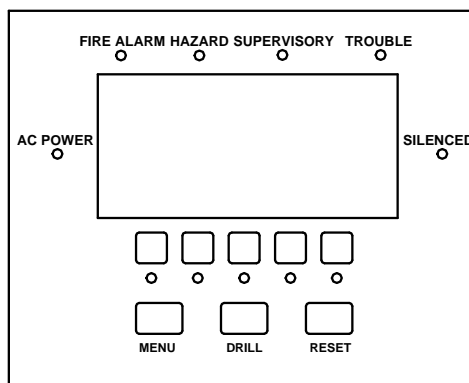

**Figure 3.1.4.1 LCD-SLP Switches**

Designation	Description
Menu	Toggles the Menu ON and OFF.
Drill	Initiates a fire drill.
Reset	Initiates a System Reset, as well as five User-Defined switches.
User Defined Switches	Custom indication and switch function, must program in CAMWorks.

**Table 3.1.4.1 Switches**

## 3.2 S3 Series System Operation

Table 3.2.1 lists the S3 Series System operation.

System Types			
<b>Local:</b>			
	Emergency relocation (paging)	Live	Pre-Recorded
	Emergency communication (telephone)		
<b>Local with Shunt:</b>			
<b>Protected premise Unit:</b>			
	Auxiliary	Proprietary	SIA CP-01-2000
	Central Station	Remote station	
<b>Supervising Station Unit:</b>			
	Auxiliary (Public Fire Alarm Reporting System)	Proprietary	
	Central Station	Remote Station	
<b>Communication Transmission Path:</b>			
	Coded	Reverse Polarity	
	Non-Coded		
<b>Releasing Cross Zone, Counting Zone and NFPA 13, Sprinkler Systems</b>			
	<b>Cross Zone</b>		
	<b>Counting Zone</b>		
	<b>NFPA 13, Sprinkler Systems</b>		

**Table 3.2.1 S3 Series System Operation**

## 3.3 Operating Instructions

Frame and mount the S3 Series Operating Instructions (Part Number: LS10056-000GF-E), adjacent to the S3 Series (Small Addressable Fire Alarm Control Panel).

## Section 4: Functionality

### 4.1 SLP Main Board Features

The SLP-E3 Main Board features shall include the following:

- An advanced micro-controller system.
- Sufficient volatile memory for either standalone or networked functionality.
- Sufficient non-volatile memory for the requisite configuration data and a minimum of 4000 event log entries.
- Support for up to two SLC-PM or SLC95-PM Personality Modules.
- Four Class B / Two Class A NACs.
- One Municipal Interface (Master Box or Polarity Reversal).
- One proprietary port for communication with the Network Interface.
- Resettable or Non-Resettable (AUX B+) Power Outputs.
- Three Form C Dry Contact outputs, one dedicated to fail-safe Trouble condition, two others user-programmable (defaulting to Alarm and Supervisory conditions).
- An isolated RS-232 serial interface for printer output and debugging.
- An Ethernet (TCP-IP) port for configuration upload/download and other functions.
- An auxiliary RS-485 port for communication with peripheral devices including displays, switch modules, and a DACT.
- A battery charger supporting up to 55 A/H lead-acid batteries.
- 24V (nominal) input connection for system power, including brownout monitoring capability.
- All necessary control switches, audible and visible indicators for a non-display operation.

Table 4.1.1 lists the SLP-E3 main board functionality.

UL Standard Functions	S3 Functionality
Drift Compensation	Yes
Remote Programming	Yes, via TCP/IP.
Extent/Limitations of Synchronization	<p>Yes</p> <p>If cross zone or inter unit synchronization is applicable, show details on the limitations and extent should be included.</p> <p><b>S3 Functionality:</b> The S3 Series panel NACs are synced alike. However, the E3 platform does not provide sync across the network.</p> <p><b>NOTE:</b> A node is a module with an address that resides on the E3 Series ARCNET network.</p> <hr/> <p>When a system is intended to provide evacuation signaling to more than one notification zone, synchronization of the audible emergency evacuation signal pattern on a notification circuit basis in lieu of a system basis is acceptable. Show details on the specifics covering the installation constraints.</p> <p><b>S3 Functionality:</b> When multiple NAC zones are implemented on the same S3 Series panel, the zones are synced alike from a common on-board sync generator. One NAC output may be used to control the extended SNAC booster panels.</p>
Calibrated Detector Sensitivity Testing	<p>For products using an automatic analog smoke detector sensitivity tests feature. The Installation Instructions should specify the extent of the range of time intervals between activations of the automatic test feature.</p> <p><b>S3 Functionality:</b> The Detector Test is automatically initiated every six hours to ensure the smoke detectors are operating within the sensitivity limits.</p>
Multiple Detection Operation for Evacuation	<p>Units employing the multiple detector operation described in 55.3.1/3.2. Include guidelines for installing of a minimum of two detectors in each protected space and to reduce the detector installation spacing to 0.7 times in the linear spacing in accordance with NFPA 72.</p> <p><b>S3 Functionality:</b> This is not a panel software function.</p>
Positive Alarm Sequence	Yes

**Table 4.1.1 SLP Main Board Functionality**

UL Standard Functions	S3 Functionality
Alarm Verification	<p>Yes, the S3 has Alarm Verification. Refer to the UL Standard 864 9th Edition, Sections 55.2 to 55.28. Figure 4.1.1.1 illustrates the Alarm Verification Timing.</p>
	<p style="text-align: center;"><b>Figure 4.1.1.1 Alarm Verification Timing</b></p>
	<p>Yes, the S3 has Two-Wire Compatibility. Refer to the Compatibility Addendum for Gamewell-FCI Manuals, P/N:9000-0427.</p> <p>An indication when a product is intended to handle detectors with optional features or a product is intended to handle more than one detector in the alarm condition shall be included.</p> <p><b>S3 Functionality:</b> Yes, the S3 is compatible with the following Two-Wire detectors: - System Sensor devices (using the SLC-PM). - Apollo devices (using the SLC95-PM). Both SLC loops must be the same protocol.</p> <p>A stipulation that detectors of different models are not to be mixed or matched on a system, unless the system is specifically intended to be installed in that configuration. When mixing is permitted, specific limitations shall be included. This information can alternatively be included in the Compatibility Section.</p> <p><b>S3 Functionality:</b> For information on compatible detector models, refer to the Compatibility Addendum for Gamewell-FCI Manuals, P/N: 9000-0427.</p>
Supervisory Signal Operation	<p>Yes (Non-Latching, Supervisory)</p> <p>For products whose operation provide the capability of selecting non automatic distinctive restoration-to-normal supervisory signals (locking in the Supervisory signals until manually reset). Include instructions or details for selecting the respective operation.</p> <p><b>S3 Functionality:</b> Supervisory Latching or Non-Latching input devices depend on the assigned device type configured in the CAMWorks Configuration Program. Supervisory Non-Latching produces a supervisory off-normal condition. Activates YELLOW “supervisory” LEDs, activates supervisory general output list. Reports event via DACT, if configured to do so. Activates supervisory contacts on panel.</p>
Manual Release/Abort Switch Interaction	No
NAC Reactivation (Alarm Resound)	<p>Yes</p> <p>When a system is intended to provide signaling service to two or more physically separated buildings or zones, re-energization of the notification appliance circuits only on a zone basis meets the intent of the requirement. Provide specifics covering installation constraints so that it shall be clearly detailed in the control unit installation wiring diagram/instructions. Systems are also not prohibited from having provision to automatically disable re-energizing alarm notification circuits due to subsequent activation of other addressable smoke detectors of the same type located in the same room or space as the initial activated device. Detail specifics.</p> <p><b>S3 Functionality:</b> Yes, the NAC Reactivation (Alarm Resound) is performed on a per-region basis.</p>

**Table 4.1.1 SLP Main Board Functionality (Continued)**

UL Standard Functions	S3 Functionality
DARC Check In:	No
Primary Power Source Failure:	Yes The primary power source failure of constantly attended supervising station equipment, for methods to determine when the fault condition is obvious to the operator on duty is covered in the instructions. <b>S3 Functionality:</b> Yes, the Primary Power Source Failure for the SLC System signals with an AC (green) LED that is lit only when the system is running from primary power.
DAC Communication Format:	Yes (Refer to the DACT-E3 Installation Instructions, P/N: 9000-0581). SIA (Refer to the DACT-E3 Installation Instructions, P/N: 9000-0581). Contact ID (Refer to the DACT-E3 Installation Instructions, P/N: 9000-0581). SK 4/2 (Refer to the DACT-E3 Installation Instructions, P/N: 9000-0581). 3/1 (Refer to the DACT-E3 Installation Instructions, P/N: 9000-0581). Other
Interconnected Control Panels:	Yes, the S3 panel has interconnected control panels. Unless interconnected control units located at a protected premises are intended to be installed such that the display annunciation at each unit can be simultaneously observed, alarm, supervisory, and trouble conditions, as well as reset, alarm silence, or trouble silence actuation originating at any unit shall be annunciated at each control unit and non-supplementary operator interface. <b>S3 Functionality:</b> Yes, on the interconnected control panels, the displayed events are prioritized, so that users can view only the events that correspond to the same priority level as that of the highest priority active event.
Walk Test:	Yes
Integrated/Network Local Functionality:	Yes, on the S3 System, the Integrated/Network Local Functionality can be used with a Daughter-Card.
Circuit disables:	Yes
Mapping:	No
Detection/Alarm Algorithms:	Yes, on the S3 System, the detection/alarm algorithms follow the device Manufacturer's specifications per the device response curves.
Day/Night Sensitivity:	Yes
Detection Sensitivity Adjustment:	No
Extent/Limitations of Combination System:	On the S3 FACP System, the extent/limitations of a combination system can be used to initiate and report CO Alarm Events, in addition to Fire Events.

**Table 4.1.1 SLP Main Board Functionality (Continued)**

### 4.1.1 Default Display Priority

Table 4.1.1.1 lists the Default Display Priority of Signals.

Condition	Unacknowledged	Acknowledged
Fire Alarm	ALARM_PLUS (14)	LOW (3)
CO/Gas Alarm	ALARM (13)	LOW (3)
Action	HIGH (9)	LOW (3)
Supervisory	HIGH (9)	LOW (3)
Trouble	MEDIUM (6)	LOW (3)
<b>NOTE:</b> Priorities can be programmed for Site-Specific requirements.		

**Table 4.1.1.1 Default Display Priority**



## 4.1.2 Expected Operations Conditions

Table 4.1.2.1 lists the conditions, response process of the condition and the expected operation.

Condition	Expected Operation
Fire Alarm	<p>The following lists the expected operation for a Fire Alarm: Alarm condition processed by Node 1 and the response process begins as follows:</p> <ul style="list-style-type: none"> <li>• Alarm LED Turned ON</li> <li>• Alarmed Device location displayed on text display</li> <li>• NAC Outputs and Municipal/Line Reversal or Releasing Output activated</li> <li>• Alarm sounder activated</li> <li>• Alarm event status message queued for broadcast on network</li> <li>• SLC Loop output devices (max. 250 for 2 loops) begin receiving</li> <li>• Activate commands on SLC Loop 1 and Loop 2 of Node 2</li> <li>• Horn Relay Contacts Transfer</li> <li>• If installed, the Alarm event information is transmitted via the DACT.</li> </ul>
CO/Gas Alarm	<p>CO/Alarm condition processed by Node 1 and the response process begins as follows:</p> <ul style="list-style-type: none"> <li>• HAZARD LED is Turned ON</li> <li>• CO/Alarmed Device location displayed on text display</li> <li>• NAC Outputs and Municipal/Line Reversal or Releasing Output activated</li> <li>• CO/Alarm sounder activated</li> <li>• CO/Alarm event status message queued for broadcast on network</li> <li>• SLC Loop output devices (max. 250 for 2 loops) begin receiving</li> <li>• Activate configured outputs on SLC Loop 1, and if used, SLC Loop 2</li> </ul>
Supervisory	<p>Supervisory condition processed by Node 1 and the response process begins as follows:</p> <ul style="list-style-type: none"> <li>• Supervisory LED Turned ON</li> <li>• Supervisory Device location displayed on text display</li> <li>• NAC Outputs and Municipal/Line Reversal or Releasing Output activated</li> <li>• Supervisory sounder activated</li> <li>• Supervisory event status message queued for broadcast on network</li> <li>• SLC Loop output devices (max. 250 for 2 loops) begin receiving</li> <li>• Activate commands on SLC Loop 1 and Loop 2 of Node 2</li> </ul>
Trouble	<p>Trouble condition processed by Node 1 and the response process begins as follows:</p> <ul style="list-style-type: none"> <li>• Trouble LED Turned ON</li> <li>• Trouble Device location displayed on text display</li> <li>• NAC Outputs and Municipal/Line Reversal or Releasing Output activated</li> <li>• Trouble sounder activated</li> <li>• Trouble event status message queued for broadcast on network</li> <li>• SLC Loop output devices (max. 250 for 2 loops) begin receiving</li> <li>• Activate commands on SLC Loop 1 and Loop 2 of Node 2</li> </ul>
<p><b>NOTE:</b> On the LCD-SLP Display, a CO Alarm illuminates a dedicated HAZARD LED.</p> <ul style="list-style-type: none"> <li>- All LCD Displays provide, Node, SLC Loop, Device Address and user text description information in the text display area.</li> <li>- The sounder produces a unique Coded 4 pattern until acknowledged.</li> <li>- The LCD-E3 Display flashes the word, "CO ALARM", in the top line in response to a CO Alarm condition in lieu of the BLUE LED. The sounder produces a coded 4 pattern until acknowledged.</li> <li>- The LCD-7100 Display flashes the word, "CO ALARM", in the top line in response to a CO Alarm condition in lieu of the BLUE LED. The sounder produces a March tone pattern until acknowledged.</li> </ul>	

**Table 4.1.2.1 Expected Operations Conditions**

## Section 5: Programming Options

### THE FOLLOWING ARE GAMEWELL-FCI PROGRAMMING SETTINGS THAT WILL BE MODIFIED FOR CAMWORKS PROGRAMMING.

#### Notice to Users, Installers, Authorities Having Jurisdiction and Other Involved Parties:

This product uses the CAMWorks™ Programming. You cannot program this product from the Display Panel. To program this product, you must contact your Gamewell-FCI Customer Support Representative to schedule a Factory Certified Training Class. Basic programming options are done using an AUTO CONFIG program and are described in the next Section.

This product incorporates field-programmable software. In order for the product to comply with the requirements in the Standard for Control Units and Accessories for Fire Alarm Systems, UL 864, certain programming features or options must be limited to specific values or not used at all as indicated in the Table 5.1.

<b>NOTE:</b> NOTICE to users, installers, Authorities Having Jurisdiction (AHJ), and other involved parties: This product incorporates field programmable software. In order for the product to comply with the requirements in the Standard for Control Units and Accessories for Fire Alarm Systems, UL Standard 864 9th Edition, certain programming features or options must be limited to specific values or not used at all as indicated below.			
<b>Programmable Feature</b>	<b>Permitted in UL 864</b>	<b>Possible Settings</b>	<b>UL Permitted Settings</b>
Trouble Reminder	Yes	Enabled/Disabled	Enabled (Default)
Supervisory Sounder Cadence	Yes	Steady/Pulsed	Steady/Pulsed
PAS Acknowledge Time	Yes	1 to 3600 Seconds	15 Seconds (Default)
PAS Investigate Time	Yes	1 to 3600 Seconds	180 Seconds (Default)
<b>Standard NAC Codes:</b>			
Temporal 3	Yes	Temporal 3	Steady (Default) Temporal 3 (ANSI S3.41)
March Time 60 BPM		March Time 60 BPM	
March Time 120 BPM		March Time 120 BPM	
Steady		Steady	
California Code		California Code	
Coded 4'S		Coded 4'S	
<b>DACT:</b>			
- Daily Max # of ALARM Reports	Yes	Unlimited or 5 to 315 by increments of 5	Unlimited (Default)
- Daily Max # of Supervisory Reports	Yes	Unlimited or 5 to 155 by increments of 5	10 (Default)
- Daily Max # of Trouble Reports	Yes	Unlimited or 5 to 155 by increments of 5	10 (Default)
AC Fail Reporting Delay by DACT	Yes	1 to 31 hours	1 to 3 hours
Alarm Event Display Priority	No	CO Highest/Fire Highest (Default)	FIRE is Highest Priority
Releasing Delay	Yes	CAMWorks Timer User Programmable 1 to 3600 Seconds	Up to 60 Seconds Maximum

**Table 5.1 Programming Options**

### 5.1 uIP Code License

From uIP® uIP® is an open source software, licensed under the following BSD-style license:

Copyright (c) 2001-2006, Adam Dunkels and the Swedish Institute of Computer Science All rights reserved.



#### **NOTE: SOFTWARE WARRANTY DISCLAIMER:**

THIS SOFTWARE IS PROVIDED BY THE AUTHOR 'AS IS' AND ANY EXPRESS OR IMPLIED WARRANTIES, INCLUDING, BUT NOT LIMITED TO, THE IMPLIED WARRANTIES OF MERCHANTABILITY AND FITNESS FOR A PARTICULAR PURPOSE ARE DISCLAIMED. IN NO EVENT SHALL THE AUTHOR BE LIABLE FOR ANY DIRECT, INDIRECT, INCIDENTAL, SPECIAL, EXEMPLARY, OR CONSEQUENTIAL DAMAGES (INCLUDING, BUT NOT LIMITED TO, PROCUREMENT OF SUBSTITUTE GOODS OR SERVICES; LOSS OF USE, DATA, OR PROFITS; OR BUSINESS INTERRUPTION). HOWEVER, CAUSED AND ON ANY THEORY OF LIABILITY, WHETHER IN CONTRACT, STRICT LIABILITY, OR TORT (INCLUDING NEGLIGENCE OR OTHERWISE) ARISING IN ANY WAY OUT OF THE USE OF THIS SOFTWARE, EVEN IF ADVISED OF THE POSSIBILITY OF SUCH DAMAGE.

## 5.2 Programming Menu Selections

System programming is performed via a portable computer and the Gamewell-FCI CAMWorks™ Configuration. The following menu options are available via the optional LCD-SLP display/keypad module.

### 5.2.1 MAIN LCD-SLP Menu Selections

Table 5.2.1.1 lists the Main LCD-SLP Menu selection and description.



**NOTE:** The SLP Firmware Version also supports the LCD-E3 sub-assembly.

Menu Selection	Description
CONFIG.	Pressing CONFIG on the Main Menu automatically opens the Autoconfig Menu, where the automatic configuration of the system is accomplished. There are three modes:
	<ul style="list-style-type: none"> <li>“Clear and Reconfigure” Use this mode to initialize a completely new sub-assembly prior to the FCP configuration.</li> </ul>
	<ul style="list-style-type: none"> <li>“Update SLCs only” This mode provides the ability to preload the system with a full configuration. Then use Autoconfigure to activate only those circuit devices that are physically present. The process can be repeated as the new SLC sections are connected or temporarily removed.</li> </ul>
	<ul style="list-style-type: none"> <li>“Accept Network Map” This mode accepts the current network map.</li> </ul>

**Table 5.2.1.1 Main LCD-SLP Menu Selections**

### 5.2.2 WALK / DRILL Menu Selection

Table 5.2.2.1 lists the Walk / Drill Menu selection and description.

Menu Selection	Description
Drill ON/OFF	Is a simple ON or OFF selection. ON will activate the NACs, while OFF will deactivate the NACs.
Audible Test	Is a simple ON or OFF selection for an Audible Walk Test. The NACs will sound twice for a trouble, sound 3 times for a supervisory signal and sound 4 times for an alarm. After the user acknowledges the condition, the system goes into trouble.
Silent Walk Test	Is a simple ON or OFF selection for a Silent Walk Test. In Velociti mode, the devices blink their own address. In Apollo or CLIP mode, the devices blink. After the user acknowledges the condition, the system goes into trouble.

**Table 5.2.2.1 Walk / Drill Menu Selection**

### 5.2.3 I/O Menu Selection

Table 5.2.3.1 lists the I/O Menu selection and description.

Menu Selection	Description
Output ON/OFF	Forces the toggling ON or OFF of a specified output. These outputs can include NAC 1, NAC 2, Municipal Circuit (if present) and any Addressable Control Point.
Enable/Disable	Allows the user to take any addressable device on either an SLC and disconnect it through software. While disabled, a point will report a trouble until it is enabled, but will not cause or respond to an alarm.

**Table 5.2.3.1 I/O Menu Selection**

### 5.2.4 CLOCK Menu Selection

Table 5.2.4.1 lists the Clock Menu selection and description.

Menu Selection	Description
Time	Is set in 24 hour notation. It is set with hours, then minutes, then seconds, “HHMMSS”.
Date	Is set as month, date and year “MMDDYY”.

**Table 5.2.4.1 Clock Menu Selection**

## 5.2.5 MISC Menu Selection

This selection opens a “MISC OPTS” Menu that allows the user to change the RS-232 port baud rate. The user can override the baud rate settings by using a DIP switch on the SLP board. The baud rate options are provided to allow the connection to a variety of printers. Although this change is temporary, it doesn’t change the configuration. Table 5.2.5.1 lists the available Baud rates.

Baud Rates	
• 115200	• 4800
• 19200	• 2400
• 9600	• 1200

**Table 5.2.5.1 Baud Rates**

## 5.2.6 LOG Menu Selection

Table 5.2.6.1 lists the Log Menu selection and description.

Menu Selection	Description
<b>Display Log</b>	Opens the System Display to all events in the buffer memory.
<b>Print Log</b>	Sends the entire buffer memory to the RS-232 port.
<b>Clear Log</b>	(Hard reset) will eliminate all events stored in the buffer memory.
<b>Sensitivity Report</b>	Sends sensor sensitivity information to the RS-232 port.

**Table 5.2.6.1 Log Menu Selection**

## 5.2.7 INFO Menu Selection

This selection displays the Firmware Version and time/date of the last configuration change in the S3 Series System. It shows a code for the type of the most recent configuration update. The INFO Menu provides the following:

1. The SLP’s current Firmware Version and Revision
2. The LCD-SLP’s Firmware Version and Revision
3. The Firmware Compile Date
4. The most recent configuration type
5. Time and date of the latest configuration
6. User-defined Installer ID
7. System Voltage
8. Battery Voltage
9. Charger Voltage
10. NAC1 EOL
11. NAC2 EOL
12. NAC3 EOL
13. NAC4 EOL

## Section 6: Testing/Maintenance

When finished with the original installation and all modifications, conduct a complete operational test on the entire installation to verify compliance with applicable NFPA standards. Testing should be conducted by a factory-trained fire alarm technician in the presence of a representative of the Authority Having Jurisdiction and the owner's representative. Follow procedures outlined in NFPA Standard 72's section on *Inspection, Testing and Maintenance*.

### Periodic Testing and Service

Periodic testing and servicing of the control panel, all initiating and notification devices, and any other associated equipment is essential to ensure proper and reliable operation. Test and service the control panel according to the schedules and procedures outlined in the following documents:

- NFPA Standard 72's section on *Inspection, Testing and Maintenance*.
- Service manuals and instructions for the peripheral devices installed in the system. Correct any trouble condition or malfunction immediately.

### Operational Checks

Between formal periodic testing and servicing intervals, the following operation checks should be performed monthly, or more frequently when required by the Authority Having Jurisdiction.

- Before proceeding: a) notify the fire department and the central alarm receiving station if transmitting alarm conditions; b) notify facility personnel of the test so that alarm sounding devices are disregarded during the test period; and c) when necessary, disable activation of alarm notification appliances and speakers to prevent their sounding.
- Disconnect all releasing devices to prevent accidental activation in accordance with NFPA 2001 and NFPA 12A releasing agents.



### WARNING:

Do not rely on disable/enable software settings to lockout releasing devices.

- Check that the green POWER LED lights are on.
- Check that all status LEDs are off.
- Press and hold the LAMP TEST key. Verify that all LEDs and all LCD display segments work.
- Activate an Initiating Device Circuit using an alarm initiating device or an addressable initiating device on the SLC and check that all programmed active notification appliances function. Reset the alarm initiating device, the control panel, and any other associated equipment. Select the paging function and confirm that the message can be heard in the affected fire zones. Repeat the above step with each Initiating Device Circuit and each addressable device.
- Remove AC power, activate an Initiating Device Circuit through an alarm initiating device or an addressable initiating device on the SLC, and check that programmed active notification appliances sound, and alarm indicators illuminate. Measure the battery voltage with notification appliances active. Replace any battery with a terminal voltage less than 21.6 VDC and reapply AC Power.



**NOTE:** The battery test requires fully charged batteries. If batteries are new or discharged due to a recent power outage, allow the batteries to charge for 48 hours before testing.

- Return all circuits to their pretest condition.
- Check that all status LEDs are off and the green POWER LED is on.
- Notify fire, central station and/or building personnel when you finish testing the system.

Battery Requirement	Batteries Used
Rechargeable battery maintenance and replacement (where a rechargeable battery is used, proper maintenance and testing procedures shall be described).	Use BAT 12120 batteries.
Replaced battery with (battery manufacturer's name or end product manufacturer's name, part number) only. Use of another battery may present a risk of fire or explosion.	Use BAT 12120 batteries. Note: This product does not use lithium batteries, N/A.

**Table 6.1 Testing and Maintenance**

## Section 7: Compatibilities

To obtain the devices that are compatible with the SLP Main Board, refer to the Compatibility Addendum for Gamewell-FCI Manuals, P/N: 9000-0427.

You can download the Compatibility Addendum for Gamewell-FCI Manuals, you can access the Gamewell-FCI Website ([www.gamewell-fci.com](http://www.gamewell-fci.com)).

In the Compatibility Addendum for Gamewell-FCI Manuals, the following devices are compatible with the SLP main board panel.

- Sensors
- Sensor Bases
- Modules
- Manual Stations
- Duct Detectors
- Two-Wire Smoke Detectors
- Four-Wire Smoke Detectors
- Notification Appliance Circuits
- NAC Sync Modules
- Systems NACs
- Releasing Solenoids

## Section 8: System Configuration

### 8.1 S3 Series System Listed Service Type Applications

Table 8.1.1 includes the service type applications Listed for the S3 Series System.

Type of Service	Model	IDC Class	Initiating Device Type	NAC Class	Type Signaling	Signal Line Circuit
Local	SLP	N/A	A, M, WF, SS	A, B	NC, M	Styles 4, 6, 7
Auxiliary	SLP	N/A	A, M, WF	N/A	N/A	Styles 4, 6, 7
Remote Station (PPU) (See Note 1)	SLP	N/A	A, M, WF	N/A	Polarity Reversal	Styles 4, 6, 7
Remote Station (PPU) (See Note 1)	SLP	N/A	A, M, WF, SS	N/A	DACT, OT	Styles 4, 6, 7
Proprietary (PPU)	SLP	N/A	A, M, WF, SS	N/A	DACT, OT	Styles 4, 6, 7
Proprietary (PPU)	SLP	N/A	A, M, WF, SS	N/A	(See Note 2)	Styles 4, 6, 7
Central Station (PPU) (See Note 1)	SLP	N/A	A, M, WF, SS	N/A	DACT, OT	Styles 4, 6, 7
Releasing	SLP	N/A	A, M, WF, SS	A, B	M, NC	Styles 4, 6, 7
<p><b>NOTE 1:</b> The designated service type used when the product is equipped with the DACT-E3 sub-assembly for DACT Type Signaling. When equipped with both DACT-E3 and separately Listed model IPDACT-2 for OT Type Signaling.</p>						
<p><b>NOTE 2:</b> The designated service type employs peer-to-peer network sharing information. Any SLC-PM or SLC95-PM node so designated is acceptable as a Proprietary PPU.</p>						

Table 8.1.1 S3 Series, Service Type Applications

### 8.2 S3 Series System Configuration

Table 8.2.1 lists the minimum S3 Series System configuration.

Accessory/ Sub-Assembly	Part Number	Description	Local	Remote Station (Rev.Pol.)	Proprietary	Auxiliary	Remote Station (DACT)	Releasing Service (Preaction/ Deluge)
SLP	SLP-RB	Smart Loop Panel - Main Board	Yes	Yes	Yes	Yes	Yes	Yes
SLC-PM	SLC-PM	SLC-PM for System Sensor Protocol	Yes	Yes	Yes	Yes	Yes	Yes
SLC95-PM	SLC95-PM	SLC95-PM for Apollo Protocol	Yes	Yes	Yes	Yes	Yes	Yes
LCD-E3	LCD-E3	LCD Display	O	O	O	O	O	O
LCD-SLP	LCD-SLP	LCD Display-SLP	Yes	Yes	Yes	Yes	Yes	Yes
FLPS-7	FLPS-7-RB	Power Supply	Yes	Yes	Yes	Yes	Yes	Yes
RPT-E3-UTP	RPT-E3-UTP	Network Repeater	O	O	O	O	O	O
FML-E3	FML-E3	Fiber-Optic Multi-Mode	O	O	O	O	O	O
FSL-E3	FSL-E3	Fiber-Optic Single-Mode	O	O	O	O	O	O
DACT-E3	DACT-E3	Digital Dialer Communicator Transmitter	No	No	Yes	Yes	Yes	O
ASM-16	1100-0455	Annunciator Switch	O	O	O	O	O	O
ANU-48	1100-0503	Annunciator	O	O	O	O	O	O
LCD-7100	1100-0399	Remote LCD Display	O	O	O	O	O	O
RAN-7100	RAN-7100	Remote LCD Display	O	O	O	O	O	O
<p><b>NOTE 1:</b> Y = Yes, N = No, and O = Optional.</p>								

Table 8.2.1 Minimum S3 Series System Configuration

## 8.3 S3 Series Module System Configurations

Table 8.3.1 lists the Modules required to make the S3 Series System Configuration.

Module	Description	Required?
SLP-E3	Smart Loop Panel - Main Board	Y (See Note 1)
SLC-PM	SLC-PM for System Sensor Protocol	Y (See Note 3)
SLC95-PM	SLC95-PM for Apollo Protocol	Y (See Note 3)
LCD-E3	LCD Display sub-assembly	O (See Note 1, 2)
LCD-SLP	LCD Display-SLP sub-assembly	Y (See Note 1), O (See Note 2)
FLPS-7	Power Supply	Y (See Note 1)
FML-E3	Fiber-Optic Multi-Mode	O (See Note 1)
FSL-E3	Fiber-Optic Single-Mode	O (See Note 1)
RPT-E3-UTP	Network Repeater sub-assembly	Y (See Note 1)
DACT-E3	Digital Dialer Communicator Transmitter	O (See Note 1)
ASM-16	Annunciator Switch Sub-Assembly	O (See Note 2)
ANU-48	Annunciator Sub-Assembly	O (See Note 2)
LCD-7100	Remote LCD Display	O (See Note 2)
RAN-7100	Remote LCD Display	O (See Note 2)
IPDACT	IP Digital Alarm Communicator	O (See Note 2)
<b>Legend for Codes in Required? Column</b>		
Y - Yes		
O - Optional		
## - Separately Listed (S1869), (S2464)		
### - Separately Listed (S1949), (S1869)		
#### - Separately Listed		
<b>Notes Describing Codes in Required? Column</b>		
<b>NOTE 1:</b> These items are modules that consist of the S3 Series control panel.		
<b>NOTE 2:</b> These items may be remotely located from the Control Panel.		
<b>NOTE 3:</b> One loop driver module is required per SLP-E3 minimum. Select SLC-PM for System Sensor or select SLC95-PM for Apollo devices. The SLP-E3 supports the use of up to two SLC-PM or SLC95-PM modules per SLC-E3. Only one type of loop driver module may be installed on a single SLP-E3. DO NOT use one SLC-PM and one SLC95-PM on a single SLP-E3.		

**Table 8.3.1 S3 Series Module System Configurations**



## Section 9: System Power/Size

Table 9.1 lists the System Power/Size currents.

Power	Current	Max. AH Capacity	Derating Factor	Max. Standby Current	Max. Alarm Current	Max. Standby Time	Max. Alarm Duration	Max. Charging Current
Primary (Power Supply)	7 A	55 A/H	.2	*3.5 amps max. continuous Standby (when the FLPS-7 is used with the SLP-E3).	*7 amps Alarm max. continuous	N/A	N/A	1 amp
Secondary (Backup)	7 A	55 A/H		1.4 amps	7 amps max.	24 Hour	5 Minutes	N/A

**NOTE:** \* The asterisk indicates that the current is based on the Battery Calculation for 4-72 hours Standby Service.

**Table 9.1 Power Supply Currents**

Table 9.2 lists the System Capacity.

Accessories/Sub-Assemblies/ Networked panels	Maximum System Capacity	
	SLC-PM (System Sensor Devices)	SLC95-PM (Apollo Devices)
Devices		
Monitor and Control Modules	318 Modules	252 Modules/Detectors
Detectors	318 Sensors	
Initiating Device Circuits (SLC)	128 SLC Circuits for a Single-Ring Network 244 SLC Circuits for a Multi-Ring Network	128 SLC Circuits for a Single-Ring Network 244 SLC Circuits for a Multi-Ring Network

**Table 9.2 System Capacity**

# Index

## C

Class 2 Power-Limited **38**

## F

FLPS-7 **10**

## L

LCD-E3

Audible/Visual Condition Indications **44**

LCD-SLP Audible/Visual Indicators

Alarm **44**

Hazard **44**

Supervisory **44**

Trouble **44**

LCD-SLP Indicators

Trouble **44**

LCD-SLP LED Indicators

AC **44**

Fire Alarm **44**

Hazard **44**

Silenced **44**

Supervisory **44**

LCD-SLP Switches

Drill **45**

Menu **45**

Reset **45**

User Defined Switches **45**

Lockout **53**

## N

Notification Appliance Circuit **15**

## R

Remote Annunciators

ANU-48 **20**

ASM-16 **20**

LCD-7100 **20**

LCD-E3 **20**

LCD-SLP **20**

RAN-7100 **20**

## S

S3 Series Module System Configurations **56**

S3 Series System Configuration **43**

Signaling Line Circuit **17**

Specifications

FLPS-7 **10**

LCD-SLP **23**

Power Output **31**

Relay Circuit **33**

Releasing Device Circuit **32**

Remote Annunciators **21**

Reverse Polarity Circuit **25**

RPT-E3-UTP **26**

SLC95-PM **19**

SLC-PM **18**

SLP-E3 **13**

Standby Battery Calculations

ANU-48 **14**

ASM-16 **14**

DACT-E3 **14**

FML-E3 **14**

FSL-E3 **14**

LCD-7100 **14**

LCD-E3 **14**

LCD-SLP **14**

RAN-7100 **14**

RPT-E3-UTP **14**

SLC95-PM **14**

SLC-PM **14**

SLP-E3 **14**

System Configuration

E3 Series Modules **56**

## W

Wiring Connections

FML-E3 **29**

FSL-E3 **30**

LCD-SLP **22**

RPT-E3-UTP **27**

SLC95-PM **19**

SLC-PM **18**

SLP-E3 **11**

## Manufacturer Warranties and Limitation of Liability

**Manufacturer Warranties.** Subject to the limitations set forth herein, Manufacturer warrants that the Products manufactured by it in its Northford, Connecticut facility and sold by it to its authorized Distributors shall be free, under normal use and service, from defects in material and workmanship for a period of thirty six months (36) months from the date of manufacture (effective Jan. 1, 2009). The Products manufactured and sold by Manufacturer are date stamped at the time of production. Manufacturer does not warrant Products that are not manufactured by it in its Northford, Connecticut facility but assigns to its Distributor, to the extent possible, any warranty offered by the manufacturer of such product. This warranty shall be void if a Product is altered, serviced or repaired by anyone other than Manufacturer or its authorized Distributors. This warranty shall also be void if there is a failure to maintain the Products and the systems in which they operate in proper working conditions.

MANUFACTURER MAKES NO FURTHER WARRANTIES, AND DISCLAIMS ANY AND ALL OTHER WARRANTIES, EITHER EXPRESSED OR IMPLIED, WITH RESPECT TO THE PRODUCTS, TRADEMARKS, PROGRAMS AND SERVICES RENDERED BY MANUFACTURER INCLUDING WITHOUT LIMITATION, INFRINGEMENT, TITLE, MERCHANTABILITY, OR FITNESS FOR ANY PARTICULAR PURPOSE. MANUFACTURER SHALL NOT BE LIABLE FOR ANY PERSONAL INJURY OR DEATH WHICH MAY ARISE IN THE COURSE OF, OR AS A RESULT OF, PERSONAL, COMMERCIAL OR INDUSTRIAL USES OF ITS PRODUCTS.

This document constitutes the only warranty made by Manufacturer with respect to its products and replaces all previous warranties and is the only warranty made by Manufacturer. No increase or alteration, written or verbal, of the obligation of this warranty is authorized. Manufacturer does not represent that its products will prevent any loss by fire or otherwise.

**Warranty Claims.** Manufacturer shall replace or repair, at Manufacturer's discretion, each part returned by its authorized Distributor and acknowledged by Manufacturer to be defective, provided that such part shall have been returned to Manufacturer with all charges prepaid and the authorized Distributor has completed Manufacturer's Return Material Authorization form. The replacement part shall come from Manufacturer's stock and may be new or refurbished. THE FOREGOING IS DISTRIBUTOR'S SOLE AND EXCLUSIVE REMEDY IN THE EVENT OF A WARRANTY CLAIM.

Warn-HL-08-2009.fm



by Honeywell

---

Gamewell-FCI  
12 Clintonville Road  
Northford, CT 06472-1610 USA  
203-484-7161  
fax 203-484-7118

[www.gamewell-fci.com](http://www.gamewell-fci.com)

**ISO 9001**  
**CERTIFIED**  
ENGINEERING & MANUFACTURING  
QUALITY SYSTEMS